

PACKAGING DIP SWITCHES

※ In addition to the DIP switches in this chapter, the following notes on the page 156 contain common notes applied to some of the pushbutton switches (detect switches), slide switches, and rotary switches described later.

BULK PACKAGING SPECIFICATIONS IN PLASTIC BAGS & BOXES

Part number	Maximum Q'ty/pack	Small packing box		
		Maximum Q'ty/small Packing box	※ 1 Dimensions W × H × D (mm)	Gross weight (g)
CJS-1200A, B	100	500	60 × 70 × 60	41
CJS-1201A, B				46
CAS-120A, B	100	500	60 × 70 × 60	41
CAS-220A, B				60
CAS-D20A, B				50
CVS-04B				80
CVS-08B	100	500	60 × 70 × 60	30
CVS-01B,C				25
CVS-02B,C				30
CVS-03B,C				39
CHS-01A, B	50	200	60 × 70 × 60	49
CHS-02A, B				60
CHS-04A, B				70
CHS-06A, B				34
CHS-08A, B				46
CHS-10A, B				58
CES-0202C	10	20	60 × 70 × 60	70
CES-0402C				47
CES-0602C				51
CES-0802C				57
CMS-2202A, B, C	50	100	60 × 70 × 60	49
CMS-2302A, B, C				55
CMS-2402A, B, C				61
CMS-2212A, B, C				49
CMS-2312A, B, C				55
CMS-2412A, B, C				61
CMS-2214A, B, C				47
CMS-2314A, B, C				49
CMS-2414A, B, C				55
CMS-4202A, B, C				49
CRFS-2202	25	50	60 × 70 × 60	72
CRFS-2302				96
S-4000A, B	50	200	60 × 70 × 60	39
SA-70 □ 0A, B, C	50	200	60 × 70 × 60	83
SA-71 □ 0A, B, C				87
SA-72 □ 0A, B, C				83
SA-70 □ 1A, B, C		100		84
SA-71 □ 1A, B, C				86
SA-72 □ 1A, B, C				84
S-70 □ 0EA, EB, EC	50	200	60 × 70 × 60	71
S-70 □ 1EA, EB, EC		100		145
CS-32-12EZA, EZB	100	500	60 × 70 × 60	40
CS-32-12EZG, EZH				65
CS-4-12YA, YB, YC	50	500	60 × 70 × 60	65
CS-4-12XA, XB, XC				65
CS-4-13NA, NB				65
CS-4-14NA, NB				65
CS-4-22YA, YB				65
CL-SB-12 □ -0 □	50	100	60 × 70 × 60	45
CL-SB-12 □ -1 □				46
CL-SB-13 □ -0 □				51
CL-SB-13 □ -1 □				52
CL-SB-22 □ -0 □				46
CL-SB-22 □ -1 □				47
CL-SB-23 □ -0 □				52
CL-SB-23 □ -1 □				53
CL-SA-12 □ □ - □ □	50	100	60 × 70 × 60	39

Part number	Maximum Q'ty/pack	Small packing box					
		Maximum Q'ty/small Packing box	※ 1 Dimensions W × H × D (mm)	Gross weight (g)			
S-10 □ 0A, S-20 □ 0A	25	50	60 × 70 × 60	57			
S-11 □ 0A, S-21 □ 0A				62			
S-12 □ 0A, 22 □ 0B				66			
S-10 □ 1A, S-20 □ 1A				70			
S-11 □ 1A, S-21 □ 1A				75			
S-12 □ 1A, 22 □ 1B				79			
SC-10 □ 0, SC-20 □ 0	25	50	60 × 70 × 60	47			
SC-11 □ 0, SC-21 □ 0				52			
SC-12 □ 0, SC-22 □ 0				47			
SC-10 □ 1, SC-20 □ 1				53			
SC-11 □ 1, SC-21 □ 1				58			
SC-12 □ 1, SC-22 □ 1				53			
SC-10 □ 0B, SC-20 □ 0B	50	100	60 × 70 × 60	47			
SC-12 □ 0B, SC-22 □ 0B				47			
SD-10 □ 0, SD-20 □ 0				48			
SD-11 □ 0, SD-21 □ 0				53			
SD-12 □ 0, SD-22 □ 0				48			
SD-10 □ 1, SD-20 □ 1				63			
SD-11 □ 1, SD-21 □ 1	25	50	60 × 70 × 60	68			
SD-12 □ 1, SD-22 □ 1				63			
SD-10 □ 0B, SD-20 □ 0B				48			
SD-12 □ 0B, SD-22 □ 0B				48			
CHP-02 □ A, 02 □ B				50	100	60 × 70 × 60	31
CHP-04 □ A, 04 □ B							41
CHP-08 □ A, 08 □ B	58						
SA-50 □ 0E	25	50	60 × 70 × 60	89			
SA-51 □ 0E				94			
SA-50 □ 1E		25		64			
SA-51 □ 1E				66			
S-80 □ 0	50	100	60 × 70 × 60	44			
S-81 □ 0				51			
S-80 □ 1				48			
S-81 □ 1				56			
SS-10-15SPE, 16NPE	25	50	60 × 70 × 60	57			
SS-10-16SP-AE, 23NPE				62			
SS-10-15SP-LE, 16NP-LE				190			
SS-10-16SP-L-AE, 23NP-LE				170			
RS1, RG1, RD1	—	20	166 × 20 × 78	190			
RS2, RG2		10		170			
RS3, RG3		10		220			

※ 1 Tolerance : ± 2

PACKAGING DIP SWITCHES

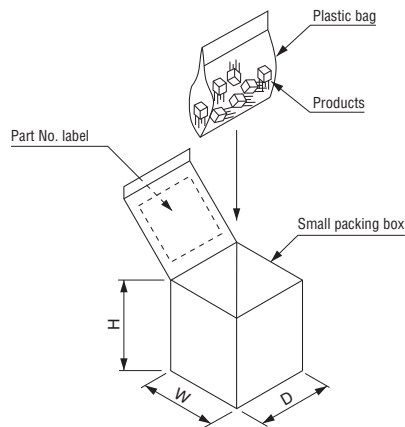
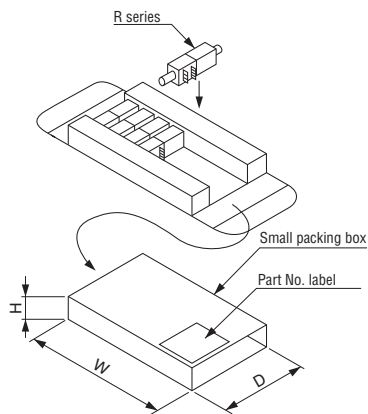

Part No. label

Type	
Spec	
Quantity	
LOT No	
Date code	
MADE IN XXX	2D barcode
□□□□ (RoHS)	
COPAL ELECTRONICS	

PACKAGING SPECIFICATIONS FOR MAGAZINE TYPE

Part number	Q'ty/stick	Magazine box		
		※ 2 Dimensions	Maximum Q'ty/Box	(g) Gross weight
CHS-04MA, MB	70	504 × 3.9 × 10.4		17
CHS-06MA, MB	50			
CHS-08MA, MB	40			
CHS-10MA, MB	30			
CFS-010 □ MA, MB, MC	118	504 × 11 × 13	4720	1440
CFS-020 □ MA, MB, MC	72		2880	1440
CFS-030 □ MA, MB, MC	52		2080	1400
CFS-040 □ MA, MB, MC	40		1600	1400
CFS-050 □ MA, MB, MC	32		1280	1400
CFS-060 □ MA, MB, MC	28		1120	1440
CFS-070 □ MA, MB, MC	24		960	1400
CFS-080 □ MA, MB, MC	20		800	1400
CFS-090 □ MA, MB, MC	18		720	1400
CFS-100 □ MA, MB, MC	16		640	1360
CFP-02 □□ MB, MC	62		504 × 13.5 × 14.8	1674
CFP-03 □□ MB, MC	46	1242		1539
CFP-04 □□ MB, MC	36	972		1512
CFP-05 □□ MB, MC	30	810		1512
CFP-06 □□ MB, MC	26	702		1512
CFP-08 □□ MB, MC	20	540		1512
CFP-10 □□ MB, MC	16	432		1512
CES-0202MC	60	504 × 17.2 × 12		1920
CES-0402MC	36		1152	2496
CES-0602MC	26		832	2496
CES-0802MC	20		640	2496
CSS-121 □ MC	53	504 × 6.6 × 5.8	4240	1040
CSS-131 □ MC	38		3040	1120
CSS-130 □ MC	38	504 × 9.7 × 3.7	3800	1600
CYP-02 □□ MB	70	500 × 7.5 × 13	4200	1920
CYP-02 □□ MC		500 × 11.5 × 13	2800	1520
CYP-04 □□ MB	40	500 × 7.5 × 13	2400	1980
CYP-04 □□ MC		500 × 11.5 × 13	1600	1560
CYP-06 □□ MB	28	500 × 7.5 × 13	1680	1980
CYP-06 □□ MC		500 × 11.5 × 13	1120	1500
CYP-08 □□ MB	20	500 × 7.5 × 13	1200	1920
CYP-08 □□ MC		500 × 11.5 × 13	800	1520
CYP-10 □□ MB	16	500 × 7.5 × 13	960	1860
CYP-10 □□ MC		500 × 11.5 × 13	640	1480
SH-70 □ OMA, MB, MC	50	390 × 17.2 × 13.4	1200	1088
CS-7-14MB				

※ 2 Tolerance ± 5

PACKAGING DIP SWITCHES

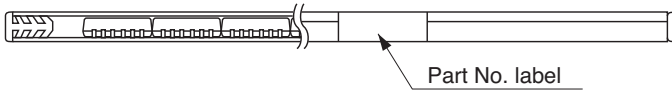

PACKAGING SPECIFICATIONS FOR TRAY TYPE

Part number	Q'ty/tray	Tray box					
		Maximum Q'ty/tray box	※ 1 Dimensions W × H × D (mm)	Gross weight (g)			
CMS-2202WC	50	500	305 × 148 × 140	528			
CMS-2302WC				553			
CMS-2402WC				578			
CMS-2212WC				538			
CMS-2312WC				568			
CMS-2412WC				598			
CMS-2214WC				538			
CMS-2314WC				568			
CMS-2414WC				598			
CMS-4202WC				728			
CMS-4216WC				748			
S-70 □ 0EWC				50	500	305 × 148 × 140	468
S-70 □ 1EWC							638
S-10 □ 0W, S-20 □ 0W				50	500	305 × 148 × 140	763
S-11 □ 0W, S-21 □ 0W	813						
S-12 □ 0W, S-22 □ 0W	893						
S-10 □ 1AW, S-20 □ 1AW	943						
S-11 □ 1AW, S-21 □ 1AW	838						
S-12 □ 1AW, S-22 □ 1AW	968						
SC-10 □ 0W, SC-20 □ 0W	50	500	305 × 148 × 140				643
SC-11 □ 0W, SC-21 □ 0W							693
SC-12 □ 0W, SC-22 □ 0W							643
SC-10 □ 1W, SC-20 □ 1W							708
SC-11 □ 1W, SC-21 □ 1W							758
SC-12 □ 1W, SC-22 □ 1W							708
SC-10 □ 0WB, SC-20 □ 0WB				643			
SC-12 □ 0WB, SC-22 □ 0WB				643			
CRFS-2202W				50	500	305 × 148 × 140	1028
CRFS-2302W							1278
CRFS-2204W							1078
CRFS-2304W							1328

Part number	Q'ty/tray	Tray box					
		Maximum Q'ty/tray box	※ 1 Dimensions W × H × D (mm)	Gross weight (g)			
SD-10 □ 0W, SD-20 □ 0W	50	500	305 × 148 × 140	653			
SD-11 □ 0W, SD-21 □ 0W				703			
SD-12 □ 0W, SD-22 □ 0W				653			
SD-10 □ 1W, SD-20 □ 1W				718			
SD-11 □ 1W, SD-21 □ 1W				768			
SD-12 □ 1W, SD-22 □ 1W				718			
SD-10 □ 0WB, SD-20 □ 0WB				653			
SD-12 □ 0WB, SD-22 □ 0WB				653			
SA-50 □ 0 □ □ EW				50	500	305 × 148 × 140	1078
SA-51 □ 0 □ □ EW							1128
SA-50 □ 1 □ □ EW							1328
SA-51 □ 1 □ □ EW				50	500	305 × 148 × 140	1368
S-80 □ 0W							463
S-81 □ 0W							498
S-80 □ 1W	493						
S-81 □ 1W	528						
SS-10-15SPEW, 16NPEW	50	500	305 × 148 × 140	748			
SS-10-16SP-AEW, 23NPEW				748			
SS-10-15SP-LEW, 16NP-LEW				798			
SS-10-16SP-L-AEW, 23NP-LEW				798			

※ 1 Tolerance ± 3

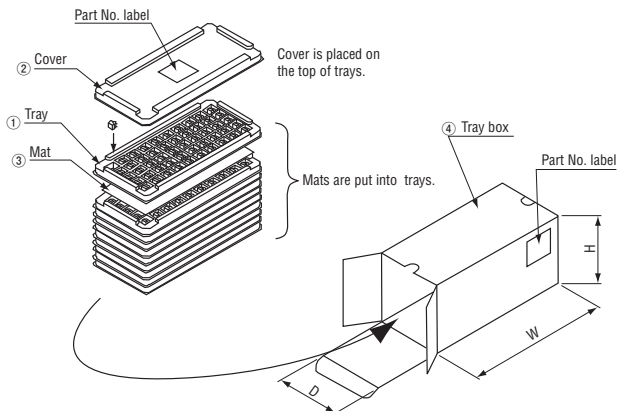

- Note) Material
- ① Tray :PS (Polystyrene)
 - ② Cover :PS (Polystyrene)
 - ③ Mat :PE (Polyethylene foam)
 - ④ Tray box :Cardboard

Part No. label

Type	
Spec	
Quantity	
LOT No	
Date code	
MADE IN XXX	
□ □ □ □ (RoHS)	
COPAL ELECTRONICS	

2D barcode

PACKAGING SPECIFICATIONS FOR TAPING TYPE (PLASTIC REEL)

Part number	Q'ty/reel	Reel box					
		Maximum Q'ty/reel box	※ 1 Dimensions W × H × D (mm)	Gross weight (g)			
CJS-1200A, B (522)/2リール	1000	2000	260 × 48 × 260	617			
CJS-1201A, B (542)/2リール				637			
CAS-120TA, TB	1000	2000	260 × 48 × 260	617			
CAS-220TA, TB				669			
CAS-D20TA, TB							
CVS-01TB	2000	4000	260 × 48 × 260	708			
CVS-02TB				719			
CVS-03TB	1000	4000	260 × 48 × 260	809			
CVS-04TB	2000	4000	260 × 48 × 260	808			
CVS-08TB				1035			
CVS-01TB-1	500	1000	185 × 46 × 188	224			
CVS-02TB-1				237			
CVS-03TB-1				251			
CVS-04TB-1				264			
CVS-08TB-1				334			
CHS-01TA, TB	1000	2000	260 × 48 × 260	617			
CHS-02TA, TB				585			
CHS-04TA, TB				633			
CHS-06TA, TB				681			
CHS-08TA, TB				843			
CHS-10TA, TB				888			
CHP-02□TA, TB	500	1000	260 × 48 × 260	647			
CHP-04□TA, TB				735			
CHP-08□TA, TB				979			
CMS-2202TA, TB	900	900	335 × 33 × 335	866			
CMS-2302TA, TB				911			
CMS-2402TA, TB				956			
CMS-2212TA, TB				932			
CMS-2312TA, TB				986			
CMS-2412TA, TB				1040			
CMS-2214TA, TB				932			
CMS-2314TA, TB				986			
CMS-2414TA, TB				1040			
CMS-4202TA, TB				500	500	335 × 41 × 335	905
CMS-4216TA, TB	1005						
CUS-12TB	2500	2500	335 × 24 × 335	780			
CUS-13TB				880			
CUS-14TB				1010			
CUS-22TB	1400	1400	335 × 24 × 335	660			
CSS-1210TB	1900	1900	335 × 24 × 335	760			
CSS-1310TB				900			
S-4010TA, TB	500	500	260 × 24 × 260	331			
SA-70□0TA, TB	500	500	335 × 24 × 335	519			
SA-71□0TA, TB				610			
SA-72□0TA, TB				519			
SA-70□1TA, TB				785			
SA-71□1TA, TB				815			
SA-72□1TA, TB				785			
SA-70□2TB				683			
SA-71□2TB				695			
SA-72□2TB				683			
SA-70□3TB				683			
SA-71□3TB				695			
SA-72□3TB				683			
CL-DA-1CB4-A2				1000	1000	260 × 24 × 260	490
CL-DA-1BB4-A2							500
CL-DB	1000	1000	260 × 24 × 260	454			
CL-SB-12A-0□T, 12B	500	500	335 × 33 × 335	648			
CL-SB-12A-1□T, 12B				648			
CL-SB-13A-0□T, 13B				672			
CL-SB-13A-1□T, 13B				677			
CL-SB-22A-0□T, 22B				651			
CL-SB-22A-1□T, 22B				655			
CL-SB-23A-0□T, 23B				680			
CL-SB-23A-1□T, 23B				686			

Part number	Q'ty/reel	Reel box			
		Maximum Q'ty/reel box	※ 1 Dimensions W × H × D (mm)	Gross weight (g)	
S-70□0ETA, ETB	500	500	260 × 24 × 260	512	
S-70□1ETA, ETB			335 × 24 × 335	763	
SH-70□0TA, TB	500	500	335 × 24 × 335	655	
CS-32-12ZETA, ZETB	500	2000	185 × 74 × 185	420	
CS-32-12ZETG, ZETH			500	260 × 20 × 260	277
CS-4-12YTA, YTB	500	2000	185 × 69 × 185	527	
CS-4-12XTA, XTB					
CS-4-13NTA, NTB					
CS-4-14NTA, NTB					
CS-4-22YTA, YTB	500	500	335 × 33 × 335	655	
CS-7-14TB					
SC-10□0TB, 20□0TB	500	500	333 × 33 × 333	816	
SC-12□0TB, 22□0TB					
SD-10□0TB, 20□0TB	500	500	333 × 33 × 333	826	
SD-12□0TB, 22□0TB					
CFS-0100TA, TB, 0101TA, TB	1000	1000	335 × 33 × 335	750	
CFS-0200TA, TB, 0201TA, TB				810	
CFS-0300TA, TB, 0301TA, TB				920	
CFS-0400TA, TB, 0401TA, TB				990	
CFS-0500TA, TB, 0501TA, TB				1110	
CFS-0600TA, TB, 0601TA, TB			1180		
CFS-0700TA, TB, 0701TA, TB			335 × 41 × 335	1370	
CFS-0800TA, TB, 0801TA, TB				1440	
CFS-0900TA, TB, 0901TA, TB			335 × 53 × 335	1670	
CFS-1000TA, TB, 1001TA, TB				1730	
CFS-0102TA, TB, 0103TB	800	800	335 × 33 × 335	690	
CFS-0202TA, TB, 0203TB				760	
CFS-0302TA, TB, 0303TB				830	
CFS-0402TA, TB, 0403TB				910	
CFS-0502TA, TB, 0503TB				980	
CFS-0602TA, TB, 0603TB			1060		
CFS-0702TA, TB, 0703TB			335 × 41 × 335	1190	
CFS-0802TA, TB, 0803TB				1350	
CFS-0902TA, TB, 0903TB			335 × 53 × 335	1430	
CFS-1002TA, TB, 1003TB				1480	
CFP-02□□TB	500	500	335 × 33 × 335	810	
CFP-03□□TB				890	
CFP-04□□TB				970	
CFP-05□□TB				1060	
CFP-06□□TB			335 × 41 × 335	1190	
CFP-08□□TB				1440	
CFP-10□□TB			335 × 53 × 335	1677	
CYP-0200B, 0201B, 0202B				700	700
CYP-0210B, 0211B, 0212B	800				
CYP-0400B, 0401B, 0402B		800			
CYP-0410B, 0411B, 0412B	980				
CYP-0600B, 0601B, 0602B		980			
CYP-0610B, 0611B, 0612B	335 × 41 × 335	1124			
CYP-0800B, 0801B, 0802B		335 × 53 × 335	1280		
CYP-0810B, 0811B, 0812B			1280		
CYP-1000B, 1001B, 1002B					
CYP-1010B, 1011B, 1012B					

Plastic (Polystyrene)
※ 1 Tolerance ±5

CS-4, CS-32 (A-B),
CVS-XX-1 reel box
CS-32 (G-H), CJS, CAS, CVS, CHS, CHP,
CFS, CFP, CMS, S-4000, SA-7000, S-7000,
SC-1000/2000, SD-1000/2000
SH-7000, CS-7, CL-DA, CL-DB, CL-SB reel box

