



CATALOG

Hydraulic-Magnetic

Circuit Protection



FOUNDED IN 1920



Since its founding, Carling Technologies has continually forged a tradition of leadership in quality and product innovation.

There are few products that Carling Technologies hasn't turned "ON" and fewer industries that haven't turned to Carling for solutions.

With ISO and TS registered manufacturing facilities and technical sales offices worldwide, Carling ranks among the world's largest manufacturers of circuit breakers, switches, power distribution units, digital switching systems and electronic controls.



SWITCHES & CONTROLS

- Electronic
- Rotary
- Rocker
- Combination
- Toggle
- Battery
- Pushbutton
- Disconnect

CIRCUIT PROTECTION

- Hydraulic-Magnetic
- Thermal
- GFCI / ELCI
- Fuse Links & Holders

CUSTOM SOLUTIONS

- PDU's
- Keypads
- Control Modules

MULTIPLEXED POWER SYSTEMS

- HMI Devices & I/O Modules
- Programmable Displays
- Data Communication Interfaces
- Electrical Systems Monitoring

STRATEGIC MARKETS SERVED:



On/Off Highway



Marine



Telecom/Datacom



Renewable Energy

HEADQUARTERS/MANUFACTURING FACILITIES:



OTHER SERVED INDUSTRIES:



Medical



Industrial Control



Audio / Visual



Commercial Food



HVAC



Floor Care



Generators



Small Appliances



Security Systems



Test & Measurement

COMPETITIVE ADVANTAGES⁺



Innovative & Eco-Friendly Products



Excellent Quality & Customer Service



Reliable & On-Time Delivery



Vertical Integration

WORLDWIDE NUMBERS:



2800⁺
EMPLOYEES



150⁺
ENGINEERS



70⁺
DISTRIBUTORS



50⁺
REP FIRMS

Table of Contents

HELPFUL TIP Click on a product to go directly to that page number!

Selector Guide	2	H-SERIES	131
A-SERIES	13	J-SERIES	145
B-SERIES	39	K-SERIES	155
TB-SERIES	57	L-SERIES	160
C-SERIES	61	M-SERIES	166
CX-SERIES	85	MS-SERIES	187
D-SERIES	96	N-SERIES	192
E-SERIES	103	R-SERIES	199
F-SERIES	112	Accessories	207
G-SERIES	122	Time Delay Values	209
		Technical Glossary	216

Available Online are tools such as a [configurit](#), [product selector](#) and [stock check](#). Please visit www.carlingtech.com for the latest information on all our products.

Application Solution Engineers are readily available to assist you in selecting the appropriate product for your application. For further assistance, please email us at team2@carlingtech.com

Custom Design Solutions can be tailor-made for most any application using our extensive engineering resources.

Other Products such as thermal, ground fault circuit breakers, switches and miniature switches are also available.

Selector Guide



A-Series

B-Series

TB-Series

C-Series

Poles	1-6 (handle) 1-3 (rocker/toggle)	1-6	2	1-6 (handle) 1-3 (rocker/toggle)
Actuator Style	sealed metal toggle, handle, rocker, paddle	handle, rocker	handle	sealed metal toggle, handle, rocker
Available Delays	AC, DC, AC/DC: instantaneous, ultra-short, short, medium & long AC, DC: high inrush-short, medium & long	AC, DC, AC/DC: instantaneous, ultra-short, short, medium & long AC, DC: high inrush-short, medium & long	AC, ultrashort, shot, medium, long, high inrush	AC, DC, AC/DC: instant, ultrashort, short, medium & long AC, DC: high inrush-short, medium & long
Max Current & Voltage Ratings	0.02-30A@ 277VAC, 80VDC 31.0-50A@ 125/250VAC, 65VDC	0.02-30A@ 277VAC, 80VDC 0.02-30A@ 125/250VAC, 65VDC	1-20A@ 120/240VAC	UL Listed: 0.02-250A@80VDC 0.1-100A@125VDC 0.02-70A@120VAC 0.02-20A@240VAC UL Recognized: 0.02-30A@480WYE/277VAC 2 Pole, 1Ø 3 Pole, 3Ø 0.02-50A@277VAC 0.02-100A@250VAC, 80VDC 0.02-100A@120/240VAC, 65VDC
Max Interrupting Capacity	7,500 amps	7,500 amps	10,000 amps; 5,000 amps TUV	10,000 amps
Auxiliary Switch Rating	10.1A@125VAC 0.1A@125VAC (gold contacts) 0.5A@65VDC 0.1A@80VDC	10.1A@125 VAC 0.1A@125 VAC (gold contacts), 0.5A@65 VDC 0.1A@80 VDC	10.1A@125 VAC 0.1A@125 VAC (gold contacts) 0.5A@65 VDC 0.1A@80 VDC	10.1A@250 VAC 0.1A@125 VAC (gold contacts), 0.5A@80 VDC
Available Circuits	series, shunt, relay, switch only, series with remote shutdown, relay & shunt trip dual coil	series, shunt, relay, switch only, series with remote shutdown, relay & shunt trip dual coil, mid-trip with alarm switch	series trip	series, shunt, relay, switch only, series with remote shutdown, relay & shunt trip dual coil, mid-trip with alarm switch
Terminal Options	.250" QC tabs 8-32 & 10-32 screw (& metric), PCB	.250" QC tabs, 8-32 & 10-32 screw (& metric), PCB	8/32, 10/32, M4, M5 back connection	10-32 stud, 1/4-20 stud, 10-32 screw with saddle clamp, 7/16 clip & push-in
Mounting Method	threaded inserts: front panel snap-in	threaded inserts: front panel snap-in	threaded inserts	threaded inserts
Agency Approvals	UL 489A, UL 1077, UL 1500, UL 508, CSA Accepted, TUV and VDE certified to IEC/EN 60934, CCC	UL 489, UL 489A, UL 1077, UL 1500, UL 508, cULus, CSA Accepted, TUV and VDE certified to IEC/EN 60934, CCC	UL 489, cULus, TUV certified to IEC/EN 60947-2	UL 489, UL 489A, UL 1077, UL 1500, UL 508, CSA Accepted, CSA Certified, TUV and VDE certified to IEC/EN 60934, TUV certified to IEC/EN 60947-2, CCC

Selector Guide



CX-Series



D-Series



E-Series



F-Series

Poles	1-5	1-4 (handle) 1-3 (rocker)	1-6	1-3
Actuator Style	handle, 1 per pole	curved rocker, visi-rocker (1 per unit), handle (1 per pole/unit)	handle	handle
Available Delays	DC: instant, ultrashort, short, medium & long	AC, DC, AC/DC: instant, ultra-short, short, medium, long AC, DC: high inrush-short, medium, long	AC, DC, AC/DC: instant, short, medium & long, high inrush-short, medium & long	AC, DC: short, medium & long
Max Current & Voltage Ratings	UL Recognized 0.2-115A @ 600VDC UL Listed 0.2-15A @ 250/500VDC 0.2-50A @ 205/410VDC	0.02-50A@ 277VAC, 65VDC 0.02-30A@ 480WYE /277VAC 2 Pole 1Ø 3 Pole 3Ø	UL Listed 0.02-100A@240VAC, 80VDC, 125VDC UL Recognized 0.02-100A@277VAC, 160VDC, 1 pole 0.02-100A@600VAC, 2 Pole 1Ø, 3 pole 3Ø 0.02-120A@125VDC, 1 pole	UL489 Listed: 50-250A@125VDC 100-250A@120/240VAC 100-250A@277VAC 100-250A@208Y/120, 3ØVAC UL489A Listed 250-700A@125VDC
Max Interrupting Capacity	10,000 amps	5,000 amps	10,000 amps	50,000 amps
Auxiliary Switch Rating	20A@80VDC (GO circuit)	n/a	10.1A@250VAC 1.0A@65VDC 0.1A@80VDC	10.1A@250VAC 0.5A@65VDC 0.1A@80VDC
Available Circuits	series trip	series, switch only, series with remote shutdown	series, shunt,relay, switch only, series with remote shutdown	series & switch only with or without metering shunt
Terminal Options	10-32 or M5 screw terminals 1/4-20 or M6 threaded stud	recessed wire-ready, pressure plate type screw terminals	10-32 stud, 1/4-20 stud 0-32 screw, 1/4-20 screw, box wire connector	3/8-16 stud, 3/8-16 screw & box wire connector
Mounting Method	threaded insert: #6-32 UNC-2B, or M3X0.5-6H B ISO (2 per pole)	rear mounted on DIN rail or front panel mounted	rear or front panel	rear or front panel
Agency Approvals	UL 489, UL 489B, UL 1077, cRUus, cULus, and TUV certified to IEC/EN 60947-2, CCC	UL 1077, UL 508, CSA Accepted and VDE certified to IEC/EN 60934	UL 489, UL 1077, UL 1500, CSA Accepted, CSA Certified and VDE certified to IEC/EN 60934, CCC	UL 489, UL 489A, cULus, TUV certified to IEC/EN 60934, CCC

Selector Guide



G-Series

H-Series

J-Series

K-Series

Poles	1-3 (UL Listed) 1-4 (UL Recognized)	1-3	1-3	1
Actuator Style	handle	handle, rocker (curved & flat)	curved rocker, flat rocker, push-to-reset guard, handle	handle
Available Delays	AC, DC: instantaneous, ultrashort, short, medium & long AC, DC: high inrush-short, medium & long	AC, DC: instantaneous, ultra-short, short, medium & long	AC, ultrashort, shot, medium, long, high inrush	DC: instantaneous, short & medium
Max Current & Voltage Ratings	UL Listed: 1-50A@80VDC 1-50A@125VDC 1-50A@120VAC 1-50A@120/240VAC 1-25A@240VAC UL Recognized: 0.2-80A@80VDC 0.2-63A@240VAC 0.2-63A@480VAC	1-35A@ 65VDC, 80VDC, 250VAC	1-20A@ 240 VAC	1-30A@65 VDC, 80 VDC, 250 VAC
Max Interrupting Capacity	5,000 amps	3,000 amps	10,000 amps; 5,000 amps TUV	1,000 amps
Auxiliary Switch Rating	3A@125VAC 2A@30VDC	1.0A @ 65VDC/0.5A @ 80VDC, 0.1A @ 125VAC (gold contacts)	n/a	n/a
Available Circuits	series, switch only	series, switch only, relay trip	series trip	series trip
Terminal Options	recessed wire-ready, pressure plate type screw terminals	.250" QC tabs 8-32 & 10-32 screw (& metric), PCB	8/32, 10/32, M4, M5	PCBA soldering terminal (0.197) Push-On 0.250 Tab (Q.C) Screw Terminal 8-32 (Bus Type)
Mounting Method	rear mounted on DIN rail	threaded inserts	threaded inserts	threaded insert with and without hook
Agency Approvals	UL 489, UL 1077, cRUus, CSA Accepted, TUV certified to IEC/EN 60934, CCC	UL 1077, CSA Accepted, TUV certified to IEC/EN 60934, CCC	UL 489, cULus, TUV certified to IEC/EN 60947-2, CCC	UL 489A, UL 1077, CSA 22.2 No. 235, TUV IEC/EN 60934, CCC GB17701

Selector Guide



L-Series



M-Series



MS-Series



N-Series



R-Series

	L-Series	M-Series	MS-Series	N-Series	R-Series
Poles	1-3	1-2	1-3	1-2	1-4
Actuator Style	rocker, with or without guard	rocker (curved & flat), visi-rocker, paddle, baton, push-to-reset & push-pull pushbuttons	sealed metal toggle	flush rocker, with or without push to reset guard	handle
Available Delays	AC: ultrashort, short, medium, long, short-high inrush, medium-high inrush, long-high inrush	AC/DC: instantaneous, short, medium, hi-inrush	DC: instantaneous, short & medium	AC: ultrashort, short, medium, long, short-high inrush, medium-high inrush, long-high inrush	DC: ultrashort, short, medium, long, 50/60 Hz ultrashort, 50/60 Hz short, 50/60 Hz medium, 50/60 Hz long
Max Current & Voltage Ratings	.1-32A@120/240VAC .1-20A@415/240VAC, 3 pole	1 Pole: 0.02-15FLA@32VDC,125VAC 15.1-25GPA@32VDC,125VAC 0.02-12FLA@250VAC 0.02-7.5GPA@50VDC 0.02-30GPA@65VDC, 80VDC 2 Pole: 0.02-15FLA@65VDC, 250VAC 15.1-25GPA@65VDC, 250VAC Parallel Pole: 31-50GPA@80VDC	0.2-30A@ 65VDC 240VAC, 120/240VAC	1-20A@240VAC 1-30A@120/240VAC	1-63A@80VDC 70-200A@80VDC Parallel Pole 1-30A@240VAC 1-50A@480VAC
Max Interrupting Capacity	5,000 amps	1,000 amps; 600 amps TUV; 500 amps VDE	3,000 amps	22,000 amps; 10,000 amps for single pole	up to 10,000 amps
Auxiliary Switch Rating	n/a	7A@250VAC 0.1A@125VAC (gold contacts) 7A (res.)@28VDC 4A (ind.)@28VDC 0.25A@80VDC	5A @ 125VAC 3A @ 32VDC .1A @ 125VAC, 32VDC	n/a	n/a
Available Circuits	series trip	series and switch only parallel pole	series and switch only	series trip	series trip
Terminal Options	10-32, 8-32, M5 & M4 screw	.250" QC tabs, 8-32 screw with upturned lugs, 8-32, 10-32 screw (bus type), push in stud terminals	.250" QC tabs 8-32 screw & solder type	screw terms	screw terminal M5 screw terminal with busbar & cage terminal
Mounting Method	threaded insert: #6-32 UNC-2B, or M3X0.5-6H B ISO (2 per pole)	snap-in front panel threaded bushing	front panel	threaded insert: #6-32 x .195 inches ISO M3 x 5mm	rear mounted on DIN rail
Agency Approvals	UL 489, cULus, TUV certified to IEC/EN 60934, CCC	UL 489A, UL 1077, CSA Accepted, TUV & VDE certified to IEC/EN 60934, CCC	UL 1077, cRUus, TUV certified to IEC/EN 60934	UL 489A, TUV certified to IEC/EN 60947-2	UL 489A, UL 1077, CSA 22.2 No. 235, TUV IEC/EN 60947-2, CCC

Circuit Protection Introduction

Any electrical or electronic equipment that is designed without including circuit protection is an accident waiting to happen. Under normal operating conditions, this may not appear to be a problem. However, normal operating conditions are not always guaranteed. Under strained or heavy use, a motor and/or another load-generating component within the equipment will draw additional current from the power source; when this happens, the equipment's wires and/or components will overheat and may ultimately burn up. Also, power surges and short circuits in unprotected equipment can cause extensive damage to the equipment and to the conductors leading to the equipment.

In addition to protecting the equipment, the entire electrical system including the control switches, wires, and power source must be protected from faults. A circuit protection device should be employed at any point where a conductor size changes. Many electronic circuits and components like transformers have a lower overload withstand threshold level than conductors such as wires and cables. These components require circuit protection devices featuring very fast overload sensing and opening capabilities.

Specifying a circuit protection device for an application is not a difficult task, but it will require some thought. If electrical and electronic equipment is designed with over-specified circuit protection devices they will be vulnerable to the damaging effects of power surges and the catastrophic results of a fire; while using under-specified circuit protection devices will result in nuisance tripping.

Before specifying a circuit protection device, equipment designers should evaluate the load characteristics during equipment startup and at normal operation. Many types of equipment will produce startup inrush current, or surges. In these cases, circuit breakers with the appropriate time delay should be selected. The time delay specified should slightly exceed the duration of the surge.

Before specifying a circuit protection device, an equipment designer should also consider the following:

- Applied voltage rating (AC or DC)
- Single phase, multi-phase/number of poles
- Applicable national electric codes and safety regulatory agency standards
- Interrupting (short circuit) capacity
- Mounting requirements and position/enclosure size constraints

The short circuit capacity of a circuit protection device should be greater than the circuit's available short circuit fault current. Available short circuit current is the maximum RMS current that would be present if all the conductors were to be connected directly to the fault location. In reality, this is not the case. The actual short circuit current is much less than the available short circuit current. The actual short circuit current is reduced due to the combined impedance of the conductors, the size of the transformer and other current restricting components within the circuit.

The application's environmental conditions must be considered when selecting the proper circuit protection device. Excessive temperature, humidity, severe vibration and shock can cause adverse performance characteristics in many types of circuit protection devices. For instance, a fuse element is less reliable when it is hot than when it is cold.

The mounting position of a hydraulic-magnetic circuit breaker is critical to its performance. A standard hydraulic-magnetic circuit breaker should be mounted on a vertical panel as gravity will influence the "must hold" and "must trip" calibration. It is possible to specify the breaker for use in other mounting positions, however, special factory calibration will be required to prevent adverse performance characteristics.

Available Choices

Carling Technologies offers three types of circuit protection devices: thermal circuit protectors, hydraulic-magnetic circuit protectors/breakers and equipment leakage circuit breakers. This catalog features hydraulic-magnetic circuit protection products. For details related to our thermal and ground fault circuit protection product lines, please visit our website.

Thermal circuit protectors utilize a bimetallic strip electrically in series with the circuit. The heat generated by the current during an overload deforms the bimetallic strip and trips the breaker. Thermal protectors have a significant advantage over fuses in that they can be reset after tripping. They can also be used as the main ON/OFF switch for the equipment being protected. However, thermal breakers have some disadvantages. They are, in effect, "heat sensing" devices, and can be adversely affected by changes in ambient temperature. When operating in a cold environment, they will trip at a higher current level. When operating in a hot environment, they will "nuisance trip" at a lower current level resulting in unwanted equipment shut downs.

Hydraulic-magnetic circuit protectors/breakers provide highly precise, reliable and cost effective solutions to most design problems. They have the advantages of thermal breakers but none of their disadvantages. The hydraulic-magnetic circuit breaker is considered to be temperature stable and thus is not appreciably affected by changes in ambient temperature. It's over-current sensing mechanism reacts only to changes of current in the circuit being protected. It has no "warm-up" period to slow down its response to overload. It has no "cool-down" period after overload before it can be reset. The characteristics of a hydraulic-magnetic circuit breaker can be tailored in four separate areas: the desired circuit; the trip point (in amperes); the time delay (in seconds); and the inrush handling capacity of the breaker. These factors can be varied with relatively little impact on the short circuit capability of the breaker. Typically, hydraulic-magnetic circuit breakers are available with a choice of three different trip time delay curves: slow, medium and long. These choices provide the designer with a high level of design flexibility when matching the breakers trip time delay curves to other circuit protection devices in a cascade, or discriminating circuit. In addition, special high-inrush constructions are available for equipment with severe inrush characteristics.

Equipment leakage circuit breakers function as hydraulic-magnetic circuit breakers, offering customized overload and short circuit protection. In addition, they sense and guard against faults to ground using innovative electronics technologies. With the exception of small amounts of leakage, the current returning to the power supply will be equal to the current leaving the power supply. If the difference between the current leaving and returning through the earth leakage circuit breaker exceeds the leakage sensitivity setting, the breaker trips and it's LED illuminates. The LED gives a clear indication that the trip occurred as a result of leakage to ground. This protection helps prevent serious equipment damage and fire.

Carling Technologies' Hydraulic-Magnetic Circuit Breakers

Carling Technologies' hydraulic/magnetic circuit breakers are current sensing devices employing a time proven hydraulic magnetic design. Their precision mechanisms are temperature stable and are not adversely affected by temperature changes in their operating environment. As such, derating considerations due to temperature variations are not normally required, and heat-induced nuisance tripping is avoided.

Features

- A trip-free mechanism, a safety feature, makes it impossible to manually hold the contacts closed during overcurrent or fault conditions.
- Worldwide safety agency approvals are available.
- Current ratings to 700 Amps and rated voltages to 600 VAC are available.
- A common trip linkage between all poles, another safety feature, ensures that an overload in one pole will trip all adjacent poles.
- Industry standard dimensions, mounting and current ratings provide maximum application versatility.
- Series trip, mid-trip and switch only (with or without auxiliary switch), remote shutdown, shunt trip, relay trip and dual coil circuit options are offered.
- Handle actuators, solid color rocker actuators, illuminated rocker actuators and the exclusive Visi Rocker® two-color rocker actuators, allow design flexibility and contemporary panel styling.
- 35mm DIN Rail back panel mounting available for world market applications.

Typical Applications

Magnetic circuit breakers protect wiring, motors, generators, transformers, solid state systems, computers, telecommunications systems, micro-processors, peripheral and printing devices, office machines, machine tools, medical and dental equipment, instrumentation, vending machines, industrial automation and packaging systems, process control systems, lamps, ballasts, storage batteries, linear and switching power supplies, as well as marine control panels and numerous other applications. Generally, wherever precise and reliable circuit protection is required, a magnetic circuit breaker is specified.

What Makes a Magnetic Breaker Trip

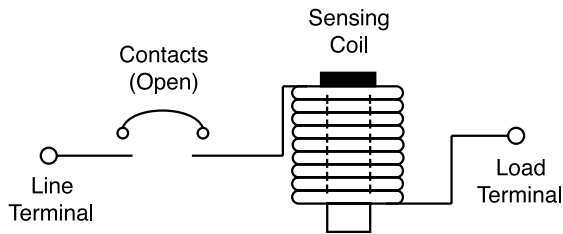

Figure 1

The most common magnetic circuit breaker configuration is called "Series Trip". It consists of a current sensing coil connected in series with a set of contacts. (Fig. 1)

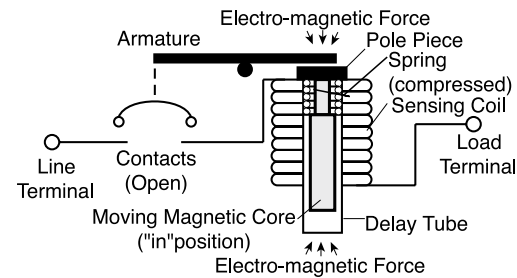

Figure 3 - Moderate Overload with Induced Delay

As the normal operating or "rated" current flows through the sensing coil, a magnetic field is created around that coil. When the current flow increases, the strength of the magnetic field increases, drawing the spring-biased, movable, magnetic core toward the pole piece. As the core moves inward, the efficiency of the magnetic circuit is increased, creating an even greater electro-magnetic force. When the core is fully "in", maximum electro-magnetic force is attained, the armature is attracted to the pole piece, unlatching a trip mechanism, thereby opening the contacts. (Fig. 3)

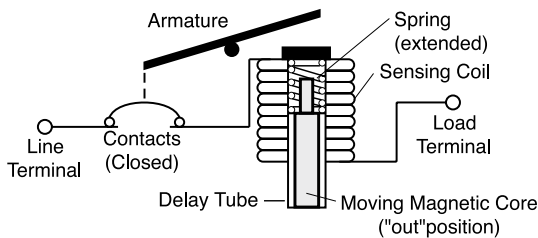

Figure 2 - Rated Current or Less

Inside the coil is a non-magnetic delay tube, housing a spring-biased, moving, magnetic core. An armature links the contacts to the coil mechanism, which functions as an electro magnet. When the contacts are open, there is no current flow through the circuit breaker, and no electro-magnetic energy is developed by the coil. When the contacts are closed, current flow begins. (Fig. 2)

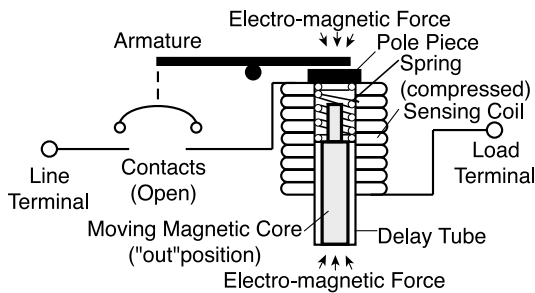

Figure 4 - Short Circuit Condition - No Induced Delay

Under short circuit conditions, the resultant increase in electromagnetic energy is so rapid, that the armature is attracted without core movement, allowing the breaker to trip without an induced delay. This is called "instantaneous trip". It is a safety feature which results in a very fast trip response when most needed. (Fig. 4)

Available Circuit Options

How Various Time Delays are Obtained

Generally speaking, the trip time of a time delay magnetic circuit breaker is directly related to the length of time it takes for the moving metal core to move to the fully "in" position. If the delay tube is filled with air, the core will move rather quickly, and the breaker will trip quickly. This is characteristic of the Ultrashort Delay Curves #11 and #21. Solid state devices, which cannot tolerate even short periods of current overload, should use Instantaneous Curves #10, #20 and #30. These curves have no intentional time delay. When the delay tube is filled with a light viscosity (temperature stable) fluid, the core's travel to the full "in" position will be intentionally delayed. This results in the slightly longer Medium Delays #14, 24, 34 and 44, which are used for general purpose applications. When a heavy viscosity fluid is used, the result will be a very long delay, such as Delay Curve #16, #26, #36 or #46. These curves are commonly used in motor applications to minimize the potential for nuisance tripping during lengthy motor start-ups. By use of magnetic "shunt" plates within the magnetic circuit, it is possible to divert magnetic flux resulting in higher "inrush withstanding capability" (or high inrush delays). These delays disregard short duration, high pulse surges (typically 8ms or less and up to 25x rated current), characteristic of transformers, switching power supplies and capacitive loads. Delay Curves #42, #44, and #46, are available for these applications. Hydraulic delay protectors have the added advantage of tripping slightly sooner when operating in higher temperature conditions and slightly longer when cold. This characteristic mirrors the protection needs in most applications. Note that the current required to trip the breaker does not change, just the time delay for tripping.

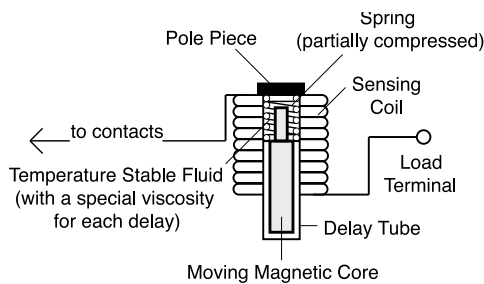

Figure 5 - Rated Current or Less

Available Circuit Options

Series Trip

Inside the coil is a non-magnetic delay tube, housing a springbiased, moving, magnetic core. An armature links the contacts to the coil mechanism, which functions as an electro magnet. When the contacts are open, there is no current flow through the circuit breaker, and no electro-magnetic energy is developed by the coil. When the contacts are closed, current flow begins. (Fig. 2)

Series Trip with Auxiliary Switch

Inside the coil is a non-magnetic delay tube, housing a springbiased, moving, magnetic core. An armature links the contacts to the coil mechanism, which functions as an electro magnet. When the contacts are open, there is no current flow through the circuit breaker, and no electro-magnetic energy is developed by the coil. When the contacts are closed, current flow begins. (Fig. 2)

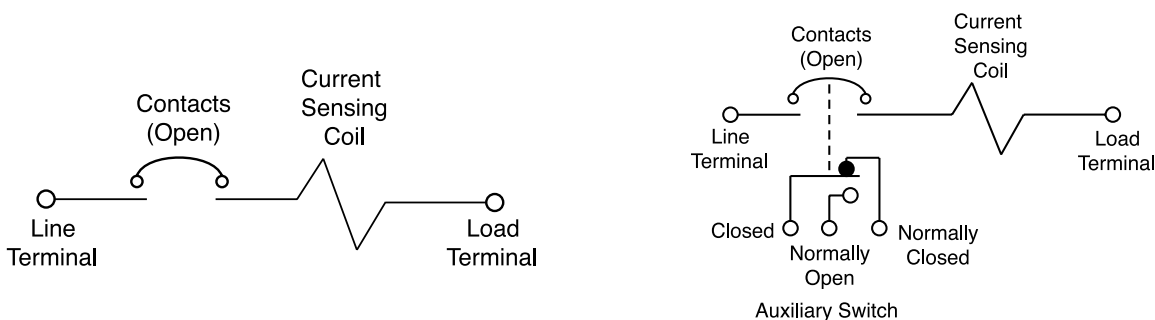

Available Circuit Options

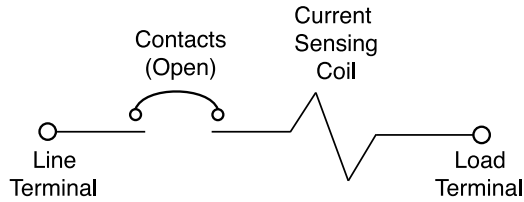

Series Mid-Trip with Auxiliary / Alarm Switch

Similar to "Series Trip with Auxiliary Switch" except the S.P.D.T. auxiliary switch is actuated solely upon electrical trip of the breaker. Upon electrical trip, the "N.O." contact closes and the "N.C." contact opens. This can be used to remotely signal the "TRIPPED" status of the breaker. Also, upon electrical trip, the handle moves to the "MID" position as opposed to the "full OFF" position typical of other breakers. This gives a specific visual panel indication of a "TRIPPED" breaker as compared to one which is merely turned OFF. Series Mid-Trip is also available without Auxiliary/Alarm Switch.

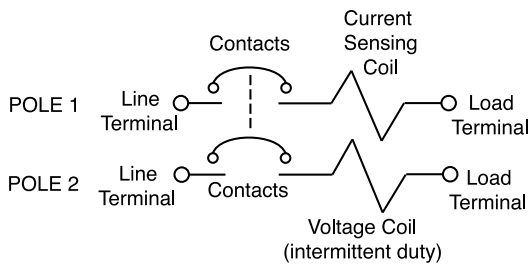

Series Trip with Remote Shutdown

(For "dump" circuit or "panic" circuit applications). Same as a Series Trip but with an additional (self-interrupting) "voltage coil" pole (usually of opposite polarity) for remote shutdown. In the example, a momentary voltage pulse to Pole 2 will shut down both Pole 1 and Pole 2. Because the voltage coil in Pole 2 is self-interrupting, no additional components, such as auxiliary switches, etc., are required in that circuit. Approximately 4 watts minimum is required to activate the voltage coil pole. This extra pole configuration is usually required by World Approval Agencies. Consult factory for this circuit.

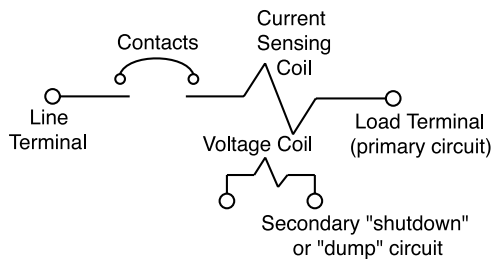

Dual Coil with Remote Shutdown

Similar to "Series Trip with Remote Shutdown" except an extra pole is NOT required. A Dual Coil breaker has two coils in the space normally occupied by a single coil. A current coil is used for overload protection and the instant trip voltage coil can be used for remote shutdown. Approximately 30 watts minimum is required to activate this type of voltage coil. Two Dual Coil options are available. The most common is the "Relay Trip Dual Coil", a four terminal device in which the voltage coil circuit is electrically isolated from the current coil circuit. This allows the triggering of the voltage coil from an independent voltage source separate from line voltage. As such, a DC pulse to the voltage coil can be used to shutdown a primary high energy AC circuit. However, because voltage coils are rated for intermittent duty, provisions must be made to disconnect the power source from the voltage coil after tripping.

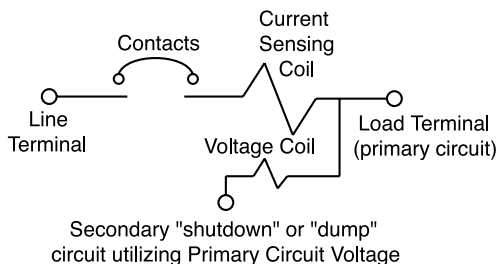

The other circuit option is the "Shunt Trip Dual Coil", a three terminal device with one side of the voltage coil internally connected to the primary circuit. The other side of the voltage coil is connected to an external third terminal on the bottom of the breaker. This circuit option uses line voltage for dual coil activation, saving wiring costs and resulting in a self-protecting voltage coil.

Available Circuit Options

Care must be taken to avoid mis-wiring of the primary and secondary (voltage coil) circuits. Mis-wiring could lead to damage to the voltage coil and/or its power source.

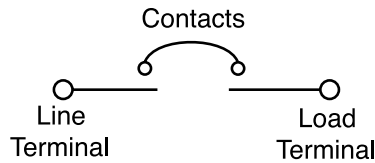

Switch Only

Same as a Series Trip, but without a sensing coil. Provides low cost, heavy-duty switch capability when overload protection is not needed. "Switch Only" is available with and without an auxiliary switch.

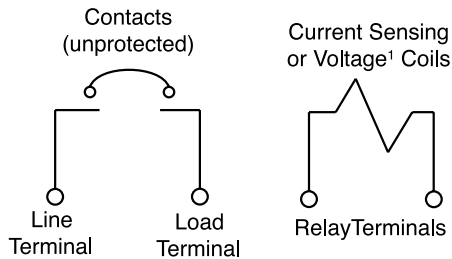

1. Voltage coils rated for intermittent duty only, and must be disconnected after being pulsed.

Relay Trip

A four terminal device in which the contact and coil circuits are electrically isolated but mechanically linked. An overload in the coil circuit will cause the contact circuit to open. These circuits may be of opposite polarity. Commonly used in dump circuit, panic circuit, and remote shutdown applications. (Note: World Approval Agencies may require a more electrically isolated voltage coil pole for this function - Ref. "Series Trip with Remote Shutdown" circuit option.)

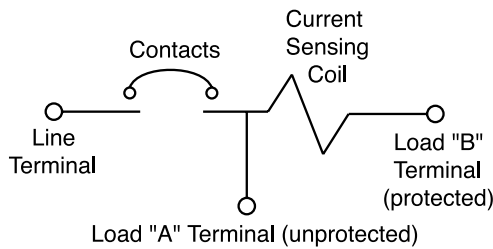

Shunt Trip

A three terminal device similar to "Series Trip", but with the addition of a third terminal between the contacts and the coil. This circuit is usually used to control two separate loads (A&B) from the same power source, while sensing overload current in only one load (B). It should be noted that overload protection is not provided in the load (A) circuit, and if needed, must be provided by other means. Also, the sum of the current in circuit A & B must not exceed the contact rating of the device.

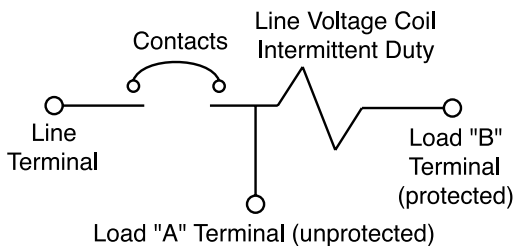

Another application possibility occurs when a voltage coil (rated for line voltage) is used. Here the load (B) terminal is connected in series with a N.O. push-button switch or similar control device. With this, a line voltage pulse through the coil can be used as a means of remotely opening the load (A) circuit. The voltage coil is self-interrupting, no additional components, such as auxiliary switches, etc., are needed in the load (B) circuit.

Regulatory Agencies/Warranty

Most countries have regulatory agencies that determine the safety and performance standards required for products used in that country. Carling Technologies' circuit breakers are tested and have been certified by the most widely recognized of these agencies including Underwriters Laboratories (UL) in the United States; Canadian Standards Association (CSA) in Canada; TUV Rheinland/Berlin-Brandenburg (TUV) and Verband Deutscher Elektrotechniker (VDE) in Germany.

UL Recognized / UL1077 Recognized

UL Recognition covers components, which are incomplete or restricted in performance capabilities. These components will later be used in complete end products or systems Listed by UL. These Recognized components are not intended for separate installation

in the field, they are intended for use as components of complete equipment submitted for investigation to UL.

Carling Technologies offers circuit breakers which are classified as supplementary circuit protectors and are Recognized under the UL Components Recognition Program as Protectors, Supplementary, UL Standard 1077. A UL 1077 Recognized supplementary circuit

protector must have a Listed overcurrent device as a "back up". Carling's M, Q, A, B, C, D and E circuit breakers offer UL 1077 Recognition.

UL Listed / UL 489 Listed

UL Listing indicates that samples of the circuit breaker as a complete product have been tested by UL to nationally recognized safety standards and have been found to be free from reasonably foreseeable risks of fire, electric shock and related hazards, and that the product was manufactured under UL's Follow-Up Services program.

Carling Technologies offers branch circuit breakers that are UL 489 Listed. Branch circuit breakers are classified as a final overcurrent device dedicated to protecting the branch circuit and outlet(s). They do not require an additional "back up" overcurrent device wired in series to protect a circuit. Carling's C, E and F-Series circuit breakers offer UL489 Listing. In addition, they are UL489A Listed for the Telecom industry.

UL1500 (MARINE)

UL1500 refers to products and components classified as ignitionprotected, and are intended to be installed and used in accordance with applicable requirements to the U.S. Coast Guard, the Fire Protection Standard for Pleasure and Commercial Motor Craft, ANSI/NFPA No. 302, and the American Boat and Yacht Council, Incorporated. Specially constructed versions of Carling Technologies' A, B and C-Series circuit breakers meet this standard.

CSA

The CSA (Canadian Standards Association) is the closest in concept and nature to UL of any group outside of the United States. Their standards and requirements are often almost identical to corresponding UL standards. CSA publishes their standards for most circuit protection devices as separate sections of CSA Standard C22.2 that in turn, forms a part of the Canadian Electrical Code. All of Carling Technologies' circuit protection products meet the applicable requirements of CSA Standard C22.2.

CUL

A CUL mark on a product means that samples of the product have been evaluated to the applicable Canadian standards and codes by Underwriters Laboratories, Inc.

VDE and TUV

There are two German government approved independent agencies, VDE (Verband Deutscher Elektrotechniker), and TUV (Technischer Überwachungs-Verein). In the circuit protection field, outside of the U.S.A. and Canada, VDE is the best known certification mark. VDE testing facilities are located in Germany.

TUV also performs testing and grants certification in accordance to the IEC/EN specifications. TUV's organization is made up of at least eleven geographically dispersed companies. At least two are

located in the United States. This aids some U.S. manufacturers in getting "fast track" approval to IEC/EN specifications.

Carling's M, H, A, B, C, D, L, E, and F-Series breakers have been certified to meet EN60934 by VDE and TUV labs.

CE MARKING

The European Union's (EU) approach to create single market access is based on four principles: harmonized directives, harmonized standards, harmonized conformity assessment procedures and CE marking. The CE marking is affixed to products indicating that the product conforms to relevant directives and standards. Various directives and standards contain the requirements for CE marking. The CE marking is primarily for market control by custom inspectors.

Before a manufacturer can affix the CE marking to their product they must complete the following steps:

1. Identify the applicable EU directive/standard
2. Perform the conformity assessment according to the applicable EU directive/standard
3. Establish a Technical File containing test reports, documentation, certificates, etc.
4. Prepare and sign a EU Declaration of Conformity

Many of Carling Technologies' circuit protection products are available with CE marking indicating conformance to Low Voltage Directive 73/23/EEC.

Warranty Policy

Carling Technologies, Inc. (Seller) warrants that goods sold hereunder shall be free of defects in material and workmanship for two years from date of shipment. In the event of such defects, the Seller's only obligation shall be the replacement or the cost of the defective goods, themselves, excluding, without limitation, labor costs, which are or may be required in connection with the replacement or reinstallation of the goods. This warranty is the Seller's sole obligation and excludes all other remedies or warranties, express or implied, including warranties of merchantability and fitness for a particular purpose, whether or not purposes or specifications are described herein. This Warranty expressly excludes any and all incidental, special and/or consequential damages of any nature. Seller further disclaims any responsibility for injury to person or damage to or loss of property or value caused by any product which has been subjected to misuse, negligence, or accident; or misapplied, or modified or repaired by a person or persons not authorized by the Seller or which have been improperly installed.

A-Series

Hydraulic-Magnetic Circuit Breaker

PRODUCT WEBPAGE

request sample, configure part

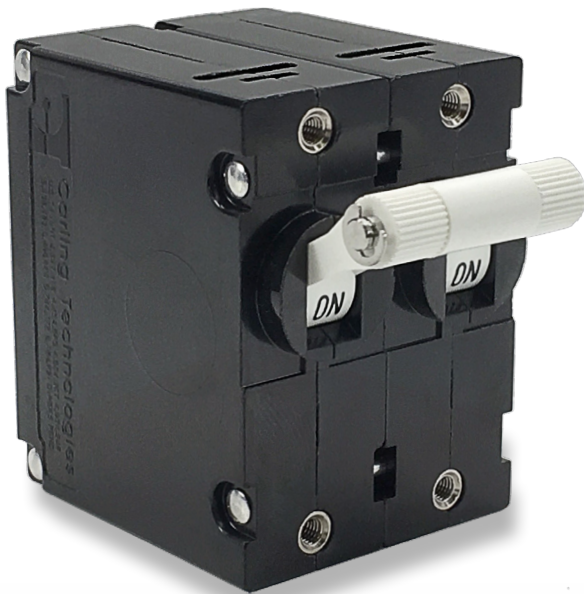

Compact and Versatile Design

The A-Series hydraulic-magnetic circuit breakers offer precise operation in a compact size for both general purpose as well as full amp load applications. Visi Rocker® and recessed paddle actuators are ideally suited for clean, front panel designs while the metal toggle configuration is ideal for harsh environments. The A-Series is available as a one to six pole configuration, rated up to 50 amps, 277VAC/80VDC and has a max IC of 7,500 amps.

1-6	50	277	80	7500A
Poles	Amps Max	VAC Max	VDC Max	Max IC

Typical Applications

- Marine
- Renewable Energy
- Welders
- Industrial Automation
- Medical Equipment
- Telecom
- Generators
- Military
- Commercial Food

Tech Specs

Electrical

Maximum Voltage	277VAC 50/60 Hz, 80VDC
Current Ratings	Standard current coils: 0.100, 0.250, 0.500, 0.750, 1.00, 2.50, 5.00, 7.50, 10.0, 15.0, 20.0, 25.0, 30.0, 35.0, 40.0, 50.0. Other ratings available - consult ordering scheme.
Standard Voltage Coils	DC-6V, 12V; AC-120V, Other ratings available, consult ordering scheme.
Auxiliary Switch Rating	SPDT; 10.1 A - 250VAC, 1.0 A-65VDC/0.5 A - 80 VDC, 0.1A - 125VAC (with gold contacts)
Insulation Resistance	Minimum: 100 Megohms at 500 VDC
Dielectric Strength	UL, CSA - 1500V 60 Hz for one minute between all electrically isolated terminals. A-Series rocker circuit breakers comply with the 8mm spacing & 3750V dielectric requirements from hazardous voltage to operator accessible surfaces per EN 60950 and VDE 0805.
Resistance, Impedance	Values from Line to Load Terminal based on Series Trip Circuit Breaker.

RESISTANCE PER POLE VALUES
from Line to Load Terminals
(Values Based on Series Trip Circuit Breaker)

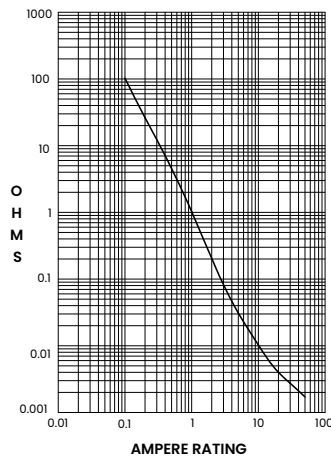

CURRENT (AMPS)	TOLERANCE (%)
0.10 - 5.0	15
5.1 - 20.0	25
20.1 - 50.0	35

Pulse Tolerance Curves

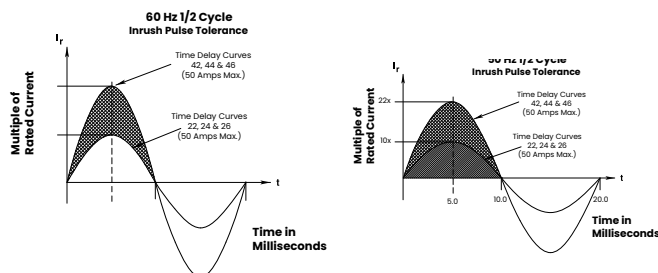

Mechanical

Endurance	10,000 ON-OFF operations @ 6 per minute; with rated Current & Voltage.
Trip Free	All A-Series Circuit Breakers will trip on overload, even when the actuator is forcibly held in the ON position.
Trip Indication	The operating actuator moves positively to the OFF position when an overload causes the circuit breaker to trip. When mid-trip handle is specified, the handle moves to the mid position on electrical trip of the circuit breaker. When mid-trip handle with alarm switch is specified, the handle moves to the mid position & the alarm switch actuates when the circuit breaker is electrically tripped.

Physical

Number of Poles	1 - 6 Poles (handle) and 1-3 poles (rocker) at 30 Amps or less. 1 and 2 poles at 31 Amps thru 50 Amps.
Internal Circuit Config.	Series, (with or without auxiliary switch), Shunt and Relay with current or voltage trip coils, Dual Coil, Switch Only with or without auxiliary switch.
Weight	Approximately 65 grams/pole. (Approximately 2.32 ounces/pole)
Standard Colors	Housing - Black; Actuator- See Ordering Scheme.

Environmental

Designed and tested in accordance with requirements of specification MIL-PRF-55629 & MIL-STD-202 as follows:

Shock	Withstands 100 Gs, 6ms, sawtooth while carrying rated current per Method 213, Test Condition "I". Instantaneous and ultra-short curves tested @ 90% of rated current.
Vibration	Withstands 0.060" excursion from 10-55 Hz, and 10 Gs 55-500 Hz, at rated current per Method 204C, Test Condition A. Instantaneous and ultrashort curves tested at 90% of rated current.
Moisture Resistance	Method 106D; ten 24-hour cycles @ +25°C to +65°C, 80-98% RH. 56 days @ +85°C, 85% RH.
Salt Spray	Method 101, Condition A (90-95% RH @ 5% NaCl Solution, 96 hrs).
Thermal Shock	Method 107D, Condition A (Five cycles @ -55°C to +25°C to +85°C to +25°C).
Operating Temperature	-40° C to +85° C

Tech Specs

Electrical Tables

Table A: Lists UL Recognized & CSA Accepted configurations and performance capabilities as a Component Supplementary Protector.

Component Supplementary Protectors										
Circuit Configuration	Voltage			Current Rating		Short Circuit Capacity (Amps)		Application Codes		Notes
	Max Rating	Frequency	Phase	Full Load Amps	General Purpose Amps	UL / CSA		UL	CSA	
						With Backup Fuse	Without Backup Fuse			
Series	32	DC	---	0.02 - 15	---	---	5000	TC1, OLI, U2	TC1, OLI, U2	
	65	DC	---	31 - 50	---	---	7500	TC1, 2, OLI, U1	TC1, 2, OLI, U1	
	80	DC	---	0.02 - 30	---	---	7500	TC1, 2, OLI, U1	TC1, 2, OLI, U1	
				---	31 - 50	---	7500	TC1, 2, OLI, U1	TC1, 2, OLI, U1	
	125	50 / 60	1	0.02 - 30	---	---	3000	TC1, OLI, U2	TC1, OLI, U2	Rocker
	125	50 / 60	1	1 - 50	---	---	2000	TC1, OLI, U2	TC1, OLI, U2	
	125	50 / 60	1 ⁴	1 - 50	---	---	1000	TC1, OLI, U2	TC3, OLI, U3	
	125 / 250	50 / 60	1 ³	0.02 - 30	---	---	3000	TC1, 2, OLI, U2	TC1, 2, OLI, U2	Rocker
	125 / 250	50 / 60	1 ³	0.02 - 50	---	---	3000	TC1, 2, OLI, U2	TC1, 2, OLI, U2	Handle
	250	50 / 60	1	0.02 - 30	---	---	1500	TC1, 2, OLI, U2	TC1, 2, OLI, U2	Single Pole
				0.02 - 30	---	---	3000	TC1, OLI, U2	TC1, OLI, U2	Two Pole
				---	---	---	3000	TC1, 2, OLI, U1	TC1, 2, OLI, U1	
				1 - 50	---	---	1000	TC1, OLI, U2	TC3, OLI, U3	
				0.02 - 30	---	5000 ²	---	TC1, 2, OLI, C1	TC1, 2, OLI, C1	
31 - 50				---	2000 ¹	---	TC1, 2, OLI, C1	TC1, 2, OLI, C1		
277	50 / 60	1	0.02 - 30	---	5000 ¹	---	TC1, 2, OLI, C1	TC1, 2, OLI, C1		
Dual Coil	32	DC	---	0.02 - 50	---	---	5000	TC1, OLI, U2	TC1, OLI, U2	
	65	DC	---	0.02 - 50	---	---	7500	TC1, 2, OLI, U1	TC1, 2, OLI, U1	
	80	DC	---	0.02 - 30	---	---	7500	TC1, 2, OLI, U1	TC1, 2, OLI, U1	
				---	31 - 50	---	7500	TC1, 2, OLI, U1	TC1, 2, OLI, U1	
	125	50 / 60	1	0.02 - 30	---	---	3000	TC1, OLI, U2	TC1, OLI, U2	Rocker
				1 - 50	---	---	2000	TC1, OLI, U2	TC1, OLI, U2	
	125	50 / 60	1 ⁴	0.02 - 30	---	---	1000	TC1, OLI, U2	TC3, OLI, U3	
	125 / 250	50 / 60	1 ³	0.02 - 30	---	---	3000	TC1, 2, OLI, U1	TC1, 2, OLI, U1	Rocker
	125 / 250	50 / 60	1 ³	0.02 - 50	---	---	3000	TC1, 2, OLI, U2	TC1, 2, OLI, U2	
	250	50 / 60	1	0.02 - 30	---	---	1500	TC1, OLI, U2	TC1, OLI, U2	Single Pole
				0.02 - 30	---	---	3000	TC1, OLI, U2	TC1, OLI, U2	Two Pole
				---	31 - 50	---	3000	TC1, 2, OLI, U1	TC1, 2, OLI, U1	
				1 - 50	---	---	1000	TC1, OLI, U2	TC3, OLI, U3	
				0.02 - 30	---	5000 ²	---	TC1, 2, OLI, C1	TC1, 2, OLI, C1	
31 - 50				---	2000 ¹	---	TC1, 2, OLI, C1	TC1, 2, OLI, C1		
277	50 / 60	1	0.02 - 30	---	5000 ¹	---	TC1, 2, OLI, U1	TC1, 2, OLI, U1		
Shunt	80	DC	---	0.02 - 30	---	---	7500	TC1, 2, OLI, U1	TC1, 2, OLI, U1	
	125 / 250	50 / 60	1	0.02 - 30	---	---	3000	TC1, 2, OLI, U1	TC1, 2, OLI, U1	
	250	50 / 60	1	0.02 - 30	---	---	3000	TC1, 2, OLI, U1	TC1, 2, OLI, U1	
				0.02 - 30	---	5000 ²	---	TC1, 2, OLI, C1	TC1, 2, OLI, C1	
	277	50 / 60	1	0.02 - 30	---	5000 ¹	---	TC1, 2, OLI, C1	TC1, 2, OLI, C1	
Relay	80	DC	---	0.02 - 30	---	---	7500	TC1, 2, OLI, U1	TC1, 2, OLI, U1	
	125 / 250	50 / 60	1 ³	0.02 - 30	---	---	3000	TC1, 2, OLI, U1	TC1, 2, OLI, U1	
	250	50 / 60	1	0.02 - 30	---	---	3000	TC1, 2, OLI, U1	TC1, 2, OLI, U1	
				0.02 - 30	---	5000 ²	---	TC1, 2, OLI, C1	TC1, 2, OLI, C1	
	277	50 / 60	1	0.02 - 30	---	5000 ¹	---	TC1, 2, OLI, C1	TC1, 2, OLI, C1	
Switch Only	65	DC	---	0.02 - 50	---	not applicable				
	80	DC	---	0.02 - 30	---	not applicable				
	250	50 / 60	1	---	31 - 50	not applicable				
			3	0.02 - 50	---	not applicable				
	277	50 / 60	1	0.02 - 30	31 - 50	not applicable				

Notes:

- 1 Requires branch circuit backup with a UL LISTED Type K5 or RK5 fuse (15A minimum) at no more than 4 times the rating of the protector.
- 2 Same as note 1, except that backup fuse is limited to 80 A maximum.
- 3 2 pole protector required (with one pole per power line) for: 125/250 VAC, 1 pole protector required for: 125 VAC, 1Ø Power System.
- 4 Satisfies the requirements of clause 11.2.8.2.5 of CSA STD C22.2 No 100 for the use of supplementary protectors with portable generators.

Tech Specs

Electrical Tables

Table B: Lists UL Recognized, CSA Accepted, VDE & TUV Certified configurations & performance capabilities as a Component Supplementary Protector.

Component Supplementary Protectors																				
Circuit Configuration	Voltage			Current Rating		Short Circuit Capacity (Amps)						Application Codes		Notes						
	Max Rating	Frequency	Phase	Full Load Amps	General Purpose Amps	UL / CSA		VDE		TUV		UL	CSA							
						With Backup Fuse	Without Backup Fuse	(Inc) with Backup Fuse	(Inc) without Backup Fuse	(Inc) with Backup Fuse	(Inc) without Backup Fuse									
Series	65	DC	---	0.10 - 50	---	---	7500	---	---	5000	3000	TC1, 2, OLI, UI	TC1, 2, OLI, UI	World Market Breaker TUV only						
				0.10 - 30	---							TC1, 2, OLI, UI	TC1, 2, OLI, UI	Handle: 1 Pole						
	80	DC	---	0.10 - 30	---	---	7500	3000	1500	3000	1500	1500	TC1, 2, OLI, UI	TC1, 2, OLI, UI	Rocker: 1-3 Poles					
				31 - 32	---								TC1, 2, OLI, UI	TC1, 2, OLI, UI	Rocker: 2 Pole					
				0.10 - 30	---								TC1, 2, OLI, UI	TC1, 2, OLI, UI	Rocker: 1 Pole					
				31 - 50	---								TC1, 2, OLI, UI	TC1, 2, OLI, UI						
				0.10 - 30	---								TC1, 2, OLI, UI	TC1, 2, OLI, UI						
				31 - 50	---								TC1, 2, OLI, UI	TC1, 2, OLI, UI						
	250	50 / 60	1	0.10 - 30	---	---	3000	---	3000	1500	5000	1500	TC1, 2, OLI, UI	TC1, 2, OLI, UI	Rocker: 1-3 Poles					
				31 - 50	---								TC1, 2, OLI, UI	TC1, 2, OLI, UI						
				31 - 32	---								TC1, 2, OLI, UI	TC1, 2, OLI, UI						
				0.10 - 30	---								TC1, 2, OLI, UI	TC1, 2, OLI, UI						
				1	0.10 - 30								---	1000	---	---	TC1, OLI, U2	TC1, OLI, U2	Rocker: 2 Pole	
				1 ⁴	1 - 50								---	---	---	---	TC1, OLI, U2	TC3, OLI, U3		
3				0.10 - 30	---								5000 ³	---	3000	1500	3000	TC1, 2, OLI, C1	TC1, 2, OLI, C1	Rocker: 1-3 Poles
31 - 50				---	2000 ²								---	---	---	---	---	TC1, 2, OLI, C1	TC1, 2, OLI, C1	
Dual Coil	80	DC	---	0.10 - 30	---	---	7500	3000	1500	3000	1500	TC1, 2, OLI, UI	TC1, 2, OLI, UI							
				0.10 - 30	---							3000	---	5000	TC1, 2, OLI, UI	TC1, 2, OLI, UI				
	250	50 / 60	1	0.10 - 30	---	---	5000 ³	---	3000	1500	3000	1500	TC1, 2, OLI, UI	TC1, 2, OLI, UI	Rocker: 1-3 Poles					
				30 - 50	---								---	---	---	---	---	---	---	
				0.10 - 30	---								---	---	---	---	---	---	---	
				31 - 50	---								2000 ²	---	---	---	---	---	---	
Shunt	80	DC	---	0.10 - 30	---	---	7500	3000	1500	3000	1500	TC1, 2, OLI, UI	TC1, 2, OLI, UI	Handle: 1 Pole						
				0.10 - 30	---							3000	---	5000	TC1, 2, OLI, UI	TC1, 2, OLI, UI				
	250	50 / 60	1	0.10 - 30	---	---	5000 ³	---	3000	1500	3000	1500	TC1, 2, OLI, UI	TC1, 2, OLI, UI	Rocker: 1-3 Poles					
				30 - 50	---								---	---	---	---	---	---		
				0.10 - 30	---								---	---	---	---	---	---		
				31 - 50	---								2000 ²	---	---	---	---	---		

Notes:

- 1 General Purpose Ratings for UL/CSA Only.
- 2 Requires branch circuit backup with a UL LISTED Type K5 or RK5 fuse (15A minimum) at no more than 4 times the rating of the protector.
- 3 Same as note 2, except that backup fuse is limited to 80 A maximum.
- 4 Satisfies the requirements of clause 11.2.8.2.5 of CSA STD C22.2 No 100 for the use of supplementary protectors with portable generators.

Tech Specs

Electrical Tables

Table C: Lists UL Recognized, CSA Accepted configurations and performance capabilities as Protectors, Supplementary for Marine Electrical and Fuel Systems (Guide PEQZ2, File E75596). Ignition Protected per UL 1500. UL Classified Small Craft Electrical Devices, Marine in accordance with ISO 8846 (Guide UZMK, File MQ1515) as Marine Supplementary Protectors.

UL1500 (Marine Ignition Protection)							
Circuit Configuration	Voltage			Current Rating Full Load Amps	Short Circuit Capacity (Amps) Without Backup Fuse	Application Codes	
	Max Rating	Frequency	Phase			UL	CSA
Series	14 ¹	DC	---	0.02 - 50	5000	TC1, OLI, U1	TC1, OLI, U1
	32 ¹					TC1, OLI, U2	TC1, OLI, U2
	65					TC1, OLI, U1	TC1, OLI, U1
	125	50 / 60	1		3000	TC1, OLI, U2	TC1, OLI, U2
	125 / 250		1 ²			TC1, OLI, U2	TC1, OLI, U2
	250		1			0.02 - 30	1500

¹ Notes:

² Available with special catalog number only (consult factory).

³ 2 pole protector required (with one per power line) for 125 / 250 VAC. 1 pole protector required for 125 VAC 1 phase power system

Table D: Lists UL Listed configurations and performance capabilities as Circuit Breakers for use in Communications Equipment

UL489A (Communications Equipment)				
Circuit Configuration	Voltage		Current Rating	Interrupting Capacity (Amps)
	Max Rating	Frequency	General Purpose Amps	without Backup Fuse
Series	80	DC	0.10 - 50	5000
			60 - 90 ¹	

Notes:

¹ Parallel Pole Construction

Time Delay Specs

To view all hydraulic-magnetic circuit breaker time delay values, please visit www.carlingtech.com/sites/default/files/documents/Carling-HM-CB-Time-Delays.pdf

Agency Approvals

UL 1077	Component Recognition Program as Protectors Supplementary (Guide CCN/QVNU2, File E75596)
UL 508	Switches, Industrial Control (Guide CCN/NRNT2, File E148683)
UL 1500	Protectors, Supplementary for Marine Electrical & Fuel Systems (Guide PEQZ2, File E75596) Ignition Protection
UL 489A	Communications Equipment (Guide CCN/DITT, File E189195)
CSA Certified	Component Supplementary Protector under Class 3215 30, File 047848 0 000 CSA Standard C22.2 No. 235
TUV Certified	EN60934, under License No. R72103448
VDE Certified	EN60934, VDE 0642 under File No. 10537

Ordering Scheme

Handle - UL 1077 Recognized

Sample Part Number **A A 3 - B 0 - 10 - 450 - 1 B 1 - C**

Selection 1 2 3 4 5 6 7 8 9 10 11

1. SERIES

A

2. ACTUATOR ¹

A Handle, one per pole
B Handle, one per multipole unit
S Mid-Trip Handle, one per pole
T Mid-Trip Handle, one per pole & Alarm Switch

3. POLES

1 One **3** Three **5** Five
2 Two **4** Four **6** Six

4. CIRCUIT

A² Switch Only (No Coil) **F**³ Relay Trip (Current)
B Series Trip (Current) **G**³ Relay Trip (Voltage)
C Series Trip (Voltage) **H**^{3,4} Dual Coil with Shunt Trip Voltage Coil
D³ Shunt Trip (Current) **K**^{3,4} Dual Coil with Relay Trip Voltage Coil
E³ Shunt Trip (Voltage)

5. AUXILIARY / ALARM SWITCH ⁵

0 without Aux Switch **7** S.P.S.T., 0.110 Q.C. Term. (Gold Contacts)
1 S.P.D.T., 0.093 Q.C. Term. **8** S.P.S.T., 0.187 Q.C. Term.
2 S.P.D.T., 0.110 Q.C. Term. **9** S.P.D.T., 0.187 Q.C. Term. (Gold Contacts)
5 S.P.S.T., 0.093 Q.C. Term. (Gold Contacts)

6. FREQUENCY & DELAY

03 DC 50/60Hz, Switch Only **31** DC, 50/60Hz Ultra Short
10 DC Instantaneous **32** DC, 50/60Hz Short
11 DC Ultra Short **34** DC, 50/60Hz Medium
12 DC Short **36** DC, 50/60Hz Long
14 DC Medium **42**⁷ 50/60Hz Short, High-inrush
16 DC Long **44**⁷ 50/60Hz Medium, High-inrush
20 50/60Hz Instantaneous **46**⁷ 50/60Hz Long, High-inrush
21 50/60Hz Ultra Short **52**⁷ DC, Short, High-inrush
22 50/60Hz Short **54**⁷ DC, Medium, High-inrush
24 50/60Hz Medium **56**⁷ DC, Long, High-inrush
26 50/60Hz Long
30 DC, 50/60Hz Instantaneous

Notes:

- Actuator Code:
 A: Handle tie pin spacer(s) and retainers provided un-assembled with multi-pole units.
 B: Handle location as viewed from front of breaker:
 2 pole - left pole 3 pole - center pole 4 pole - two handles at center poles
 5 pole - three handles at center poles 6 pole - four handles at center poles
 S: Handle moves to mid-position only upon electrical trip of the breaker. Available with circuit codes B, C, D, E, F, G, H and K.
 T: Handle moves to mid-position and alarm switch activates only upon electrical trip of the breaker. Available with circuit codes B & C.
- Switch Only circuits, rated up to 50 amps and 6 poles, and only available when tied to a protected pole (Circuit Code B, C, D or H). For .02 to 30 amps, select Current Code 630. For 35 - 50 amps, select Current Code 650.
- Available with terminal Codes 1, 2 and 3. Current Rating limited to 50A amps maximum.
- Consult factory for available Dual Coil options, as special catalog number is required. With Shunt construction, Dual Coils will trip instantaneously on line volt age. Dual coils require 30VA minimum power to trip and are rated for intermittent duty only.
- Auxiliary Switch breakers with Series Trip & Switch Only circuits: ≤ 30A - supplied with standard half shells. 35-50A - supplied with extended boat (B-Style) half shells. On multi-pole breakers, one auxiliary switch is supplied, mounted in the extreme right pole.
- Separate pole type voltage coils not rated for continuous duty. Available only with delay codes 10 and 20.
- Available with Circuit Codes B & D only. VDE Certified to 30 amps. UL Recognized, CSA Accepted & TUV Certified to 50 amps.
- VDE Certification available with single pole breakers with DC Delay only. UL Recognition and CSA Accepted available in one and two pole breakers.
- Screw Terminals are recommended on ratings greater than 20 amps. Ratings over 30 amps are only available with Terminal Codes 5, 9, G, H, M and Q.
- Terminal Code I: VDE Certification up to 25 amps and UL Recognition and CSA Certification up to 30 amps, but not recommended over 20 amps.
- Terminal Codes 3, 5, E and H (Bus Type) with VDE, are supplied with Lock Washers, and Terminal Code M (M6 Threaded Stud) with VDE is supplied with Lock and Flat Washers. These breakers are only VDE Certified when the washers are used.
- Terminal Code L: VDE Certified available up to 12A. UL Recognized & CSA Accepted available up to 30A.
- Single pole breakers with Terminal Code P (Printed Circuit Board) are available up to 30 amps with VDE Certification and 50 amps with UL Recognition and CSA Accepted, with Circuit Codes A, B and C. Two pole breakers with Terminal Code P (Printed Circuit Board) are available up to 40 amps with UL Recognition and CSA Accepted with Circuit Codes A, B and C.
- Terminal Code Q not available with VDE certification.
- Single pole only.

7. CURRENT RATING (AMPERES)

CODE	AMPERES						
020	0.020	225	0.250	420	2.000	611	11.000
025	0.025	230	0.300	522	2.250	711	11.500
030	0.030	235	0.350	527	2.750	612	12.000
035	0.035	240	0.400	430	3.000	712	12.500
040	0.040	245	0.450	435	3.500	613	13.000
045	0.045	250	0.500	440	4.000	614	14.000
050	0.050	255	0.550	445	4.500	615	15.000
055	0.055	260	0.600	450	5.000	616	16.000
060	0.060	265	0.650	455	5.500	617	17.000
065	0.065	270	0.700	460	6.000	618	18.000
070	0.070	275	0.750	465	6.500	620	20.000
075	0.075	280	0.800	470	7.000	622	22.000
080	0.080	285	0.850	475	7.500	624	24.000
085	0.085	290	0.900	480	8.000	625	25.000
090	0.090	295	0.950	485	8.500	630	30.000
095	0.095	410	1.000	490	9.000	6358	35.000
210	0.100	512	1.250	495	9.500	6408	40.000
215	0.150	415	1.500	610	10.000	6458	45.000
220	0.200	517	1.750	710	10.500	6508	50.000

OR VOLTAGE COIL (NORMAL RATED VOLTAGE) ⁶

A06	6 DC	A32	32 DC	J12	12 AC	J65	65 AC
A12	12 DC	A48	48 DC	J18	18 AC	K20	120 AC
A18	18 DC	A65	65 DC	J24	24 AC	L40	240 AC
A24	24 DC	J06	6 AC	J48	48 AC		

8. TERMINAL ⁹

1 ¹⁰	Push-On 0.250 Tab (Q.C.)	B	Screw M5 with upturned lugs
2	Screw 8-32 with upturned lugs	C	Screw, M4 with upturned lugs
3 ¹¹	Screw 8-32 (Bus Type)	E ¹¹	Screw M4 (Bus Type)
4	Screw 10-32 with upturned lugs	F	Screw M5 with upturned lugs & 30° bend
5 ¹¹	Screw 10-32 (Bus Type)	G	Screw M5 (Bus Type) & 30° bend
6	Screw 8-32 with upturned lugs & 30° bend	H ¹¹	Screw M5 (Bus Type)
7	Screw 8-32 (Bus Type) & 30° bend	L ¹²	0.250 Q.C./ Solder Lug
8	Screw 10-32 with upturned lugs & 30° bend	M ¹¹	M6 Threaded Stud
9	Screw 10-32 (Bus Type) & 30° bend	P ¹³	Printed Circuit Board Terminals
		Q ¹⁴	Push-In Stud
		R	Screw, M4 with upturned lugs & 30° Bend
		S ¹³	Push-On 0.110 Tab (Q.C.)
		T ¹¹	Screw, M4 with upturned lugs

9. ACTUATOR COLOR & LEGEND

Actuator Color	I-O	ON-OFF	Dual	Legend
White	A	B	1	Black
Black	C	D	2	White
Red	F	G	3	White
Green	H	J	4	White
Blue	K	L	5	White
Yellow	M	N	6	Black
Gray	P	Q	7	Black
Orange	R	S	8	Black
Black (short handle) ¹⁵	T	U	9	White

10. MOUNTING / BARRIERS

	MOUNTING STYLE	BARRIERS
	Threaded Insert, 2 per pole	
1	6-32 x 0.195 inches	no
A	6-32 x 0.195 inches	yes
2	ISO M3 x 5mm	no
B	ISO M3 x 5mm (multipole only)	yes
	Front panel Snap-In, 0.75" wide bezel	
5	without Handleguard	no
6	without Handleguard (multipole only)	yes
	Front panel Snap-In, 0.96" wide bezel	
7	without Handleguard, 1-pole 0.96" wide;	no
	multipole units have .105" bezel overhang on all sides	
8	without Handleguard, 1-pole 0.96" wide;	yes
	(multipole only) .105" bezel overhang on all sides	

11. AGENCY APPROVAL

C UL Recognized & CSA Accepted
D VDE Certified, UL Recognized & CSA Accepted
E TUV Certified, UL Recognized & CSA Accepted
I UL Recognized STD 1077, UL Recognized 1500 (ignition protected), & CSA Accepted

Configure Complete Part Number >

Browse Standard Parts >

Ordering Scheme

Handle - UL 489A Listed

Sample Part Number

A A 1 - B 0 - 14 - 450 - 1 B 1 - M T

Selection 1 2 3 4 5 6 7 8 9 10 11 12

1. SERIES

A

2. ACTUATOR ¹

A Handle, one per pole
S Mid-Trip Handle, one per pole
T Mid-Trip Handle, one per pole & Alarm Switch

3. POLES ²

1 One 3 Three
2 Two 4 Four

4. CIRCUIT

B Series Trip (Current)

5. AUXILIARY/ALARM SWITCH ²

0 without Aux Switch 7 S.P.S.T., 0.110 Q.C. Term. (Gold Contacts)
1 S.P.D.T., 0.093 Q.C. Term. 8 S.P.S.T., 0.187 Q.C. Term.
2 S.P.D.T., 0.110 Q.C. Term. 9 S.P.D.T., 0.187 Q.C. Term.
5 S.P.S.T., 0.093 Q.C. Term. (Gold Contacts)

6. FREQUENCY & DELAY

11 DC Ultra Short 52³ DC, Short, High-inrush
12 DC Short 54³ DC, Medium, High-inrush
14 DC Medium 56³ DC, Long, High-inrush
16 DC Long

7. CURRENT RATING (AMPERES)

CODE	AMPERES						
210	0.100	285	0.850	455	5.500	613	13.000
215	0.150	290	0.900	460	6.000	614	14.000
220	0.200	295	0.950	465	6.500	615	15.000
225	0.250	410	1.000	470	7.000	616	16.000
230	0.300	512	1.250	475	7.500	617	17.000
235	0.350	415	1.500	480	8.000	618	18.000
240	0.400	517	1.750	485	8.500	620	20.000
245	0.450	420	2.000	490	9.000	622	22.000
250	0.500	522	2.250	495	9.500	624	24.000
255	0.550	527	2.750	610	10.000	625	25.000
260	0.600	430	3.000	710	10.500	630	30.000
265	0.650	435	3.500	611	11.000	635 ³	35.000
270	0.700	440	4.000	711	11.500	640 ³	40.000
275	0.750	445	4.500	612	12.000	645 ³	45.000
280	0.800	450	5.000	712	12.500	650 ³	50.000

8. TERMINAL

1⁶ Push-On 0.250 Tab (Q.C.)
2 Screw 8-32 with upturned lugs
3⁷ Screw 8-32 (Bus Type)
4 Screw 10-32 with upturned lugs
5⁷ Screw 10-32 (Bus Type)
6 Screw 8-32 with upturned lugs & 30° bend
7 Screw 8-32 (Bus Type) & 30° bend
8 Screw 10-32 with upturned lugs & 30° bend
9 Screw 10-32 (Bus Type) & 30° bend
B Screw M5 with upturned lugs
F Screw M5 with upturned lugs & 30° bend
G Screw M5 (Bus Type) & 30° bend
H Screw M5 (Bus Type)
M⁷ M6 Threaded Stud
P⁸ Printed Circuit Board Terminals
Q⁹ Push-In Stud & 30° bend

9. ACTUATOR COLOR & LEGEND

Actuator Color	ON-OFF	Dual	Legend Color
White	B	1	Black
Black	D	2	White
Red	G	3	White
Green	J	4	White
Blue	L	5	White
Yellow	N	6	Black
Gray	Q	7	Black
Orange	S	8	Black
Black (short handle) ¹⁰	U	9	White

10. MOUNTING / BARRIERS ⁹

MOUNTING STYLE	BARRIERS
Threaded Insert, 2 per pole	
1 6-32 x 0.195 inches	no
A 6-32 x 0.195 inches	yes
2 ISO M3 x 5mm	no
B ISO M3 x 5mm (multipole only)	yes
Front panel Snap-In, 0.75" wide bezel	
5 without Handleguard	no
6 without Handleguard (multipole only)	yes
Front panel Snap-In, 0.96" wide bezel	
7 without Handleguard, 1-pole 0.96" wide;	no
8 multipole units have .105" bezel overhang on all sides without Handleguard, 1-pole 0.96" wide;	yes
(multipole only) .105" bezel overhang on all sides	

11. MAXIMUM APPLICATION RATING

M 80 DC

12. AGENCY APPROVAL

T UL489A Listed
K UL489A Listed, VDE Certified
J UL489A Listed, TUV Certified

Notes:

- Actuator Code:
A: Handle tie pin spacer(s) and retainers provided un-assembled with multi-pole units.
S: Handle moves to mid-position only upon electrical trip of the breaker.
T: Handle moves to mid-position and alarm switch activates only upon electrical trip of the breaker.
- On multi-pole breakers, one auxiliary switch is supplied, mounted in the extreme right pole.
- VDE Certified to 30 amps. UL489A Listed to 50 amps.
- VDE Certification available with single pole breakers only. UL489A Listing available with one and two pole breakers.
- Screw Terminals are recommended on ratings greater than 20 amps. Ratings over 30 amps are only available with Terminal Codes 5, 9, G, H, M and Q.
- Terminal Code 1 (Push-On) available up to 25 amps with VDE Certification and 30 amps with UL489A Listing, but is not recommended over 20 amps.
- Terminal Codes 3, 5 and H (Bus Type) with VDE, are supplied with Lock Washers, and Terminal Code M (M6 Threaded Stud) with VDE is supplied with Lock and Flat Washers. These breakers are only VDE Certified when the washers are used.
- Single pole breakers with Terminal Code P (Printed Circuit Board) are available up to 30 amps with VDE Certification and 50 amps with UL489A Listing.
- Terminal Code Q not available with VDE certification.
- Single pole only.

[Configure Complete Part Number >](#)

[Browse Standard Parts >](#)

Ordering Scheme

Handle - World

Sample Part Number

A A 3 - B 0 - 14-450 - 1 A 1 - P

Selection

1 2 3 4 5 6 7 8 9 10 11

1. SERIES

A

2. ACTUATOR ¹

A Handle, one per pole
B Handle, one per multipole unit
S Mid-Trip Handle, one per pole
T Mid-Trip Handle, one per pole & Alarm Switch

3. POLES

1 One **3** Three **5** Five
2 Two **4** Four **6** Six

4. CIRCUIT

A ² Switch Only (No Coil) **D** ³ Shunt Trip (Current)
B Series Trip (Current) **E** ³ Shunt Trip (Voltage)
C Series Trip (Voltage) **H** ^{3,4} Dual Coil with Shunt Trip Voltage Coil

5. AUXILIARY / ALARM SWITCH ⁵

0 without Aux Switch
2 S.P.D.T., 0.110 Q.C. Term.

6. FREQUENCY & DELAY

03 DC 50/60Hz, Switch Only **30** DC, 50/60Hz Instantaneous
10 DC Instantaneous **31** DC, 50/60Hz Ultra Short
11 DC Ultra Short **32** DC, 50/60Hz Short
12 DC Short **34** DC, 50/60Hz Medium
14 DC Medium **36** DC, 50/60Hz Long
16 DC Long **42** ⁷ 50/60Hz Short, High-inrush
20 50/60Hz Instantaneous **44** ⁷ 50/60Hz Medium, High-inrush
21 50/60Hz Ultra Short **46** ⁷ 50/60Hz Long, High-inrush
22 50/60Hz Short **52** ⁷ DC, Short, High-inrush
24 50/60Hz Medium **54** ⁷ DC, Medium, High-inrush
26 50/60Hz Long **56** ⁷ DC, Long, High-inrush

7. CURRENT RATING (AMPERES)

CODE	AMPERES	
210	0.100	285 0.850
215	0.150	290 0.900
220	0.200	295 0.950
225	0.250	410 1.000
230	0.300	512 1.250
235	0.350	415 1.500
240	0.400	517 1.750
245	0.450	420 2.000
250	0.500	522 2.250
255	0.550	527 2.750
260	0.600	430 3.000
265	0.650	435 3.500
270	0.700	440 4.000
275	0.750	445 4.500
280	0.800	450 5.000
		455 5.500
		460 6.000
		465 6.500
		470 7.000
		475 7.500
		480 8.000
		485 8.500
		490 9.000
		495 9.500
		610 10,000
		710 10,500
		611 11,000
		711 11,500
		612 12,000
		712 12,500
		613 13,000
		614 14,000
		615 15,000
		616 16,000
		617 17,000
		618 18,000
		620 20,000
		622 22,000
		624 24,000
		625 25,000
		630 30,000
		635 ⁸ 35,000
		640 ⁸ 40,000
		645 ⁸ 45,000
		650 ⁸ 50,000

OR VOLTAGE COIL (NORMAL RATED VOLTAGE) ⁶

A06	6 DC	A32	32 DC	J12	12 AC	J65	65 AC
A12	12 DC	A48	48 DC	J18	18 AC	K20	120 AC
A18	18 DC	A65	65 DC	J24	24 AC	L40	240 AC
A24	24 DC	J06	6 AC	J48	48 AC		

8. TERMINAL

1 ¹⁰ Push-On 0.250 Tab (Q.C.)
2 Screw 8-32 with upturned lugs
3 ¹¹ Screw 8-32 (Bus Type)
4 Screw 10-32 with upturned lugs
5 ¹¹ Screw 10-32 (Bus Type)
6 Screw 8-32 with upturned lugs & 30° bend
7 Screw 8-32 (Bus Type) & 30° bend
8 Screw 10-32 with upturned lugs & 30° bend
9 Screw 10-32 (Bus Type) & 30° bend
B Screw M5 with upturned lugs
C Screw, M4 with upturned lugs
E ¹¹ Screw M4 (Bus Type)
F Screw M5 with upturned lugs & 30° bend
G Screw M5 (Bus Type) & 30° bend
H ¹¹ Screw M5 (Bus Type)
M M6 Threaded Stud
R Screw, M4 with upturned lugs & 30° Bend
T ¹¹ Screw, M4 with upturned lugs

9 ACTUATOR COLOR & LEGEND

Actuator Color	I-O	Dual	Legend Color
White	A	1	Black
Black	C	2	White
Red	F	3	White
Green	H	4	White
Blue	K	5	White
Yellow	M	6	Black
Gray	P	7	Black
Orange	R	8	Black
Black (short handle) ⁵	T	9	White

10. MOUNTING / BARRIERS

MOUNTING STYLE	BARRIERS
1 Threaded Insert, 2 per pole	
A 6-32 x 0.195 inches	no
2 6-32 x 0.195 inches	yes
B ISO M3 x 5mm	no
B ISO M3 x 5mm (multipole only)	yes
5 Front panel Snap-In, 0.75" wide bezel without Handleguard	no
6 without Handleguard (multipole only)	yes
7 Front panel Snap-In, 0.96" wide bezel without Handleguard, 1-pole 0.96" wide;	no
8 multipole units have .105" bezel overhang on all sides without Handleguard, 1-pole 0.96" wide; (multipole only) .105" bezel overhang on all sides	yes

11. AGENCY APPROVAL

P TUV Certified, UL Recognized & CSA Accepted
Q UL Recognized STD 1077, UL Recognized 1500 (ignition protected), & CSA Accepted

Notes:

- Actuator Code:
A: Handle tie pin spacer(s) and retainers provided unassembled with multi-pole units.
S: Handle moves to mid-position only upon electrical trip of the breaker. Available with circuit codes B, C, D, E, and H.
T: Handle moves to mid-position and alarm switch activates only upon electrical trip of the breaker. Available with circuit codes B & C.
- Switch Only circuits, rated up to 50 amps and 6 poles, and only available when tied to a protected pole (Circuit Code B, C, D or H). For .01 to 30 amps, select Current Code 630. For 35 - 50 amps, select Current Code 650.
- Available with terminal Codes 1, 2 and 3. Current Rating limited to 30 amps maximum.
- Consult factory for available Dual Coil options, as special catalog number is required. With Shunt construction, Dual Coils will trip instantaneously on line volt age. Dual coils require 30VA minimum power to trip and are rated for intermittent duty only.
- On multi-pole breakers, one auxiliary switch is supplied, mounted in the extreme right pole.
- Separate pole type voltage coils not rated for continuous duty. Available only with delay codes 10, 20 & 30.
- Available with Circuit Codes B & D only. VDE Certified to 30 amps. UL Recognized, CSA Accepted & TUV Certified to 50 amps.
- Available up to two poles with AC or DC delays.
- Screw Terminals are recommended on ratings greater than 20 amps. Ratings over 30 amps are only available with Terminal Codes 5, 9, G and H.
- Terminal Code I: TUV Certification up to 30 amps, but not recommended over 20 amps.
- Terminal Codes 3, 5, 7, 9, E, G and H (Bus Type) are supplied with Lock Washers. These breakers are only TUV Certified when the washers are used.
- Single pole only.

[Configure Complete Part Number >](#)

[Browse Standard Parts >](#)

Circuit & Terminal Diagrams Handle

inches [millimeters]

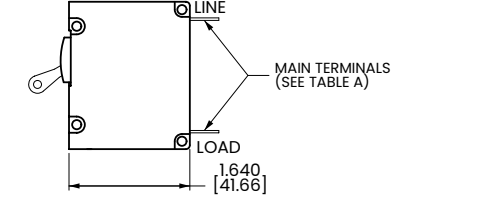
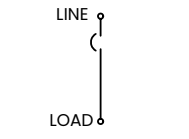
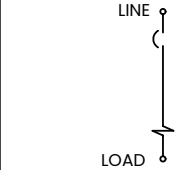
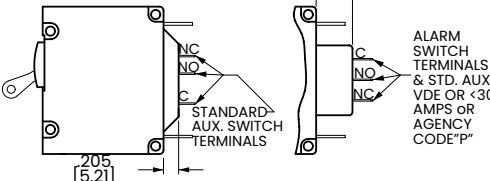
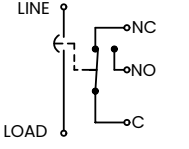
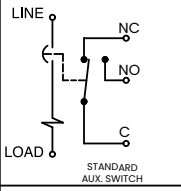
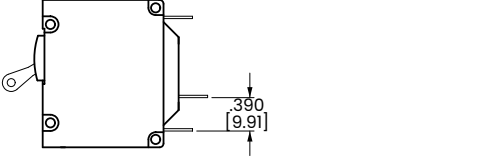
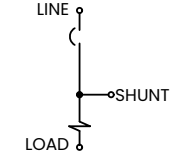
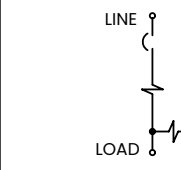
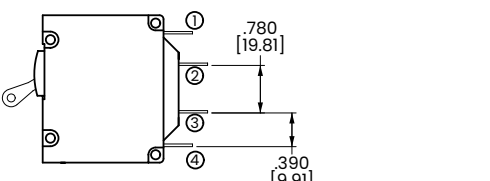
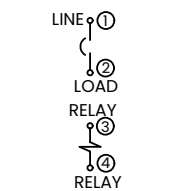
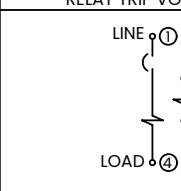
CIRCUIT BREAKER PROFILE	CIRCUIT SCHEMATIC		CIRCUIT SCHEMATIC	
	ANSI	CIRCUIT CODE	ANSI	CIRCUIT CODE
2 TERMINALS 	SWITCH ONLY (NO COIL) 	ANSI SERIES TRIP 	BC 0	BC 0
5 TERMINALS 	SWITCH ONLY (NO COIL) WITH AUXILIARY SWITCH 	SERIES TRIP WITH (3) AUXILIARY/ALARM SWITCH 	A BC 1 2 3 4	BC 1 2 3 4
3 TERMINALS 	SHUNT TRIP 	DUAL COIL; SERIES TRIP CURRENT COIL, RELAY TRIP VOLTAGE COIL 	DE 0	H 0
4 TERMINALS 	RELAY TRIP 	DUAL COIL; SERIES TRIP CURRENT COIL, RELAY TRIP VOLTAGE COIL 	FG 0	K 0

AUXILIARY/ALARM SWITCH TERMINAL DETAIL

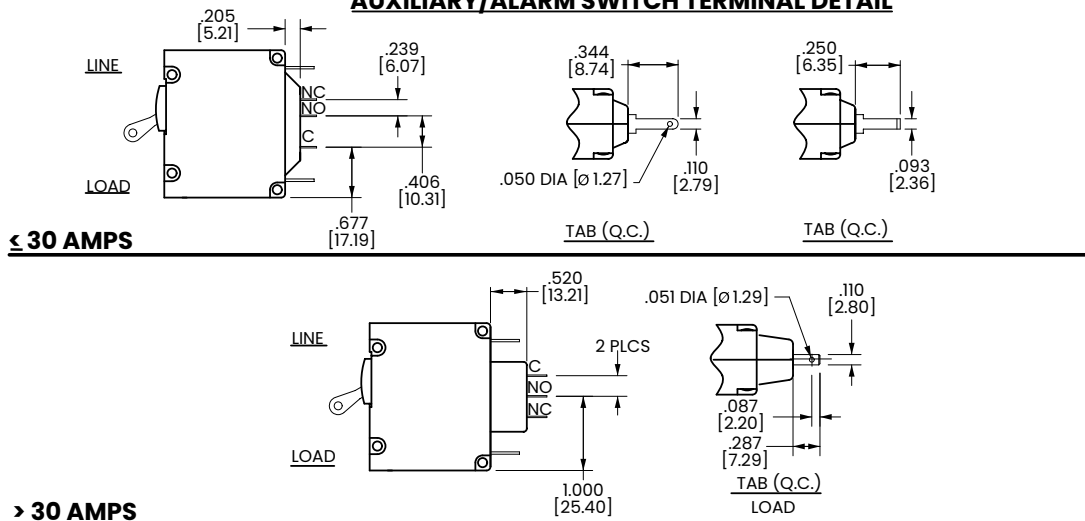

- Notes:
 1 Tolerance $\pm .020$ [51] unless otherwise specified.
 2 Alarm Switch available with .110 x .020 Q.C. & Solder Lug Terminals Only.

Circuit & Terminal Diagrams Handle

inches [millimeters]

HANDLE POSITION VS. AUX/ALARM SWITCH MODE						
CIRCUIT BREAKER MODE	STANDARD C/B		MID TRIP C/B		MID TRIP C/B	
	HANDLE POSITION	AUX. SWITCH MODE	HANDLE POSITION	ALARM SWITCH MODE	HANDLE POSITION	AUX. SWITCH CODE (W/O ALARM SWITCH)
OFF						
ON						
ELECTRICAL TRIP						

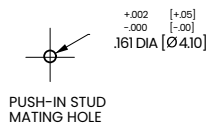
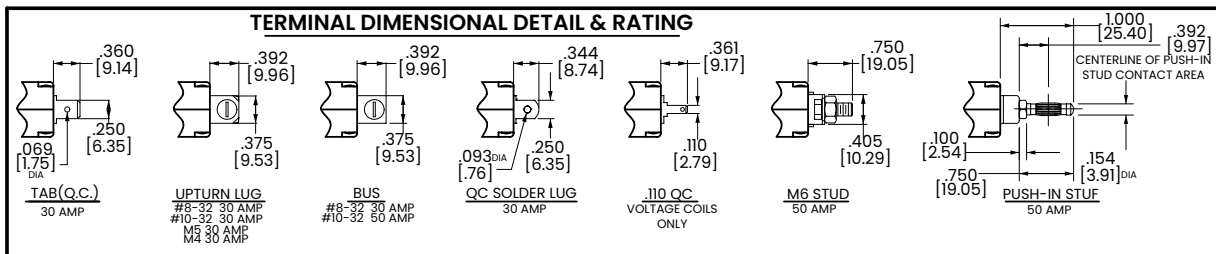

**TABLE A
TIGHTENING TORQUE SPECIFICATIONS**

THREAD SIZE	TORQUE
#8-32 & M3 MOUNTING HARDWARE	7-9 IN-LBS [0.8-1.0 NM]
#8-32 & M4 THREAD TERMINAL SCREW	12-15 IN-LBS [1.4-1.7 NM]
#10-32 & M5 THREAD TERMINAL SCREW	15-20 IN-LBS [1.7-2.3 NM]

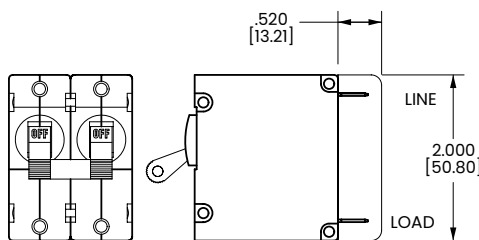

BARRIER FOR UL-RECOGNIZED MULTI-POLE BREAKERS

TABLE B

TERMINAL DESCRIPTION		DEPTH BEHIND PANEL
MAIN	TAB (Q.C.)	2.000 [50.80]
	SCREW TYPE	2.032 [51.60]
SHUNT, RELAY & DUAL COIL	TAB (Q.C.)	2.207 [56.10]
	SCREW #8-32 W/UPTURNED LUGS	2.364 [60.05]
AUX. SWITCH*	.093 TAB (Q.C.)	2.095 [53.20]
	.110 TAB (Q.C.)	2.189 [55.60]
	SOLDER TYPE	1.970 [50.00]

*AVAILABLE ON SERIES TRIP AND SWITCH ONLY CIRCUITS WHEN CALLED FOR ON MULTI-POLE UNITS. ONLY ONE AUX. SWITCH IS NORMALLY SUPPLIED, AS SHOWN IN MULTI-POLE IDENTIFICATION SCHEME.

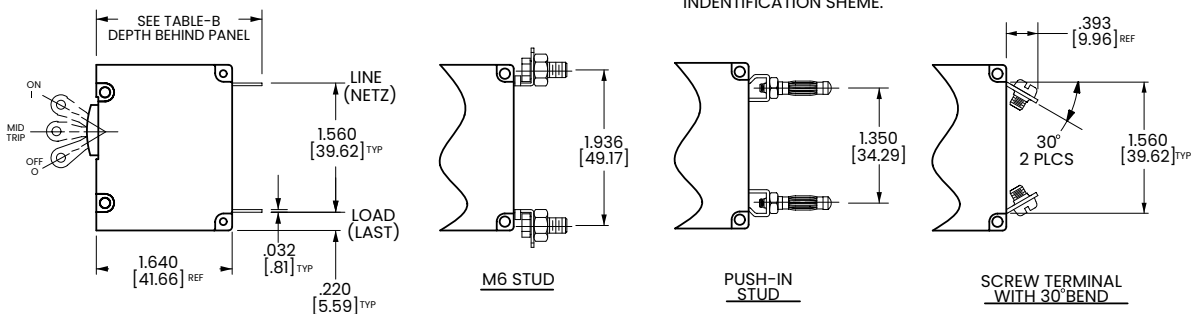

- Notes:
- 1 Tolerance ±.020 [.51] unless otherwise specified.
 - 2 Alarm Switch available with .110 x .020 QC & solder lug terminals only.

Dimensional Specs Handle

inches [millimeters]

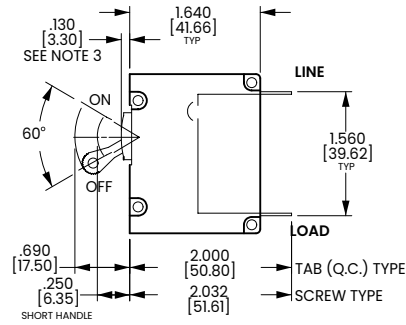
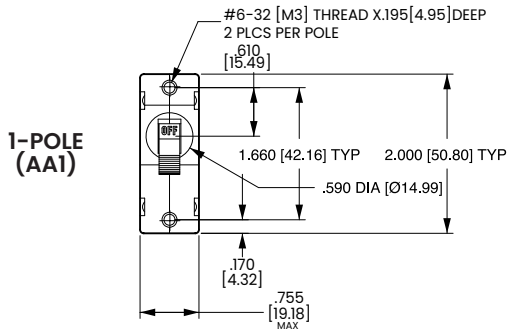

TAB (Q.C.) TYPE TERMINALS IN SERIES TRIP CONCUIT CONFIGURATION SHOWN. FOR OTHER CONFIGURATIONS SEE CIRCUIT & TERMINAL DIAGRAMS

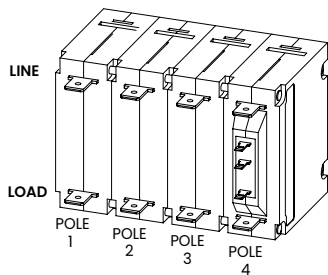
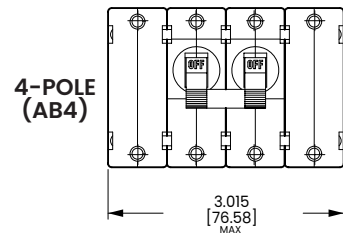
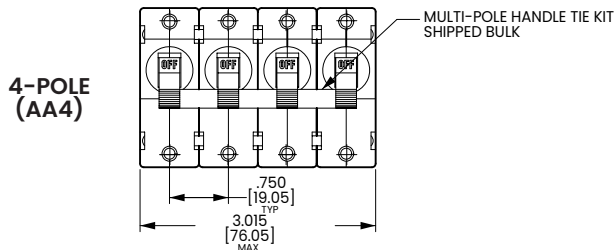
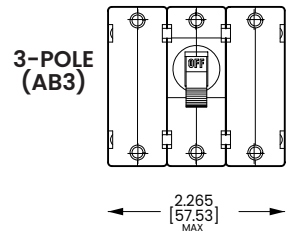
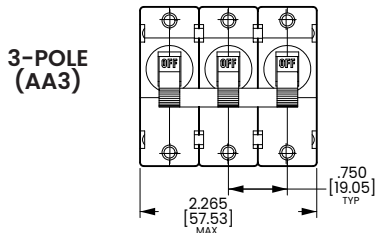
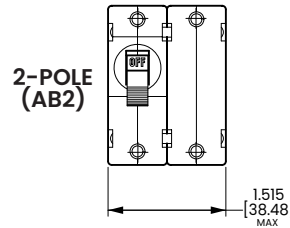
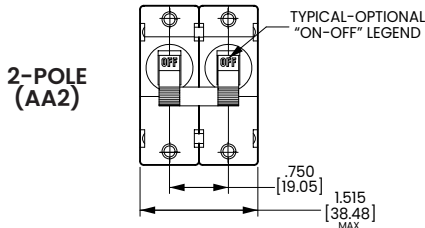

MULTI-POLE IDENTIFICATION SCHEME AS VIEWED FROM TERMINAL END OF BREAKER.

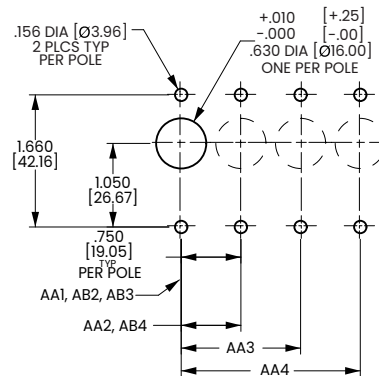

PANEL CUTOUT DETAIL
TOLERANCE ±.005 [±.12] UNLESS OTHERWISE SPECIFIED

- Notes:
1 Tolerance ± 0.20 [.51] unless otherwise specified.
2 For agency code P = .150 [3.81].

Dimensional Specs Handle

inches [millimeters]

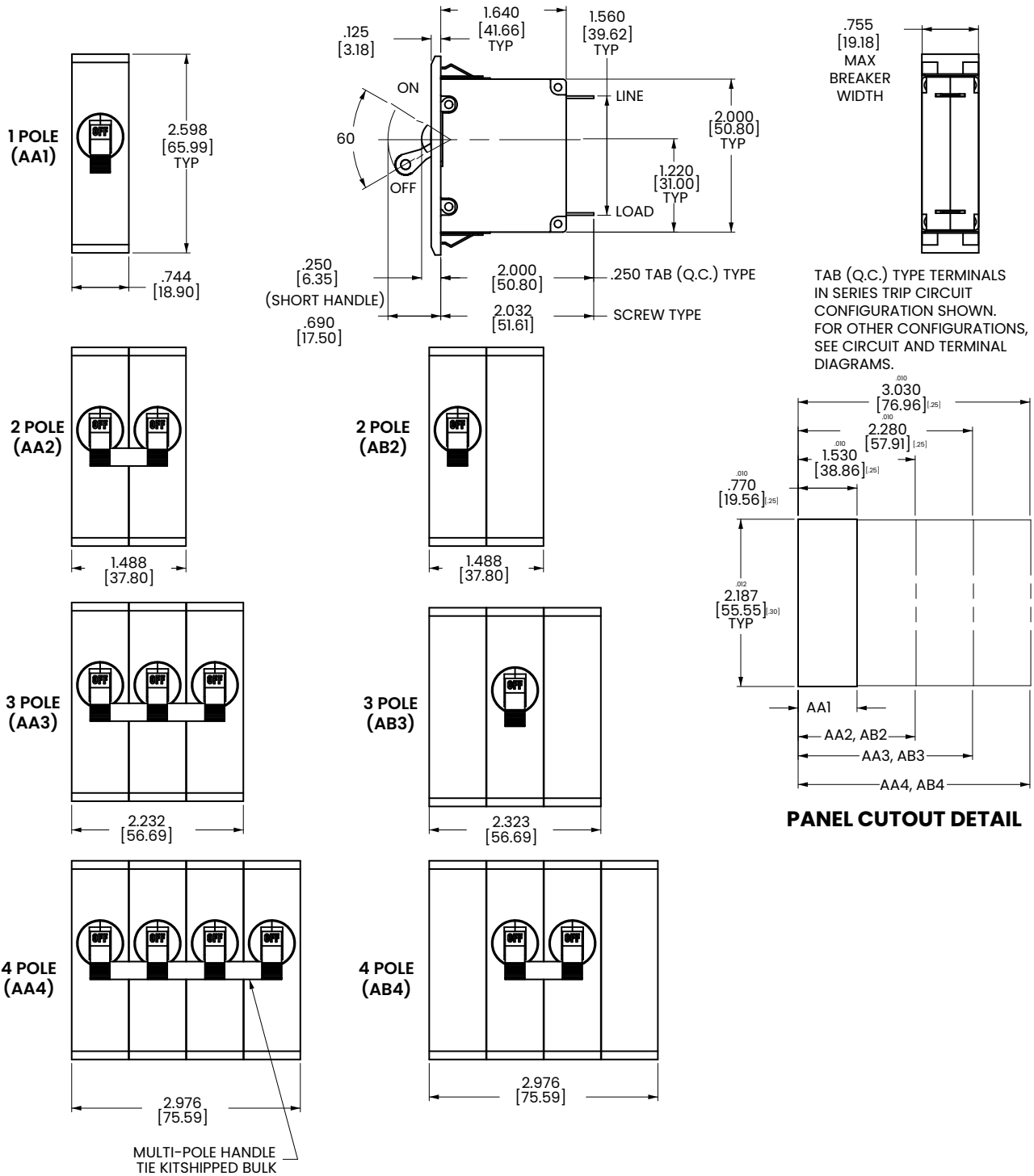

TAB (Q.C.) TYPE TERMINALS IN SERIES TRIP CIRCUIT CONFIGURATION SHOWN. FOR OTHER CONFIGURATIONS, SEE CIRCUIT AND TERMINAL DIAGRAMS.

Notes:
 1 Recommended panel thickness: .040 [1.02] to .100 [2.54].
 2 Tolerance ±.020 [.51] unless otherwise specified.

Dimensional Specs Handle

inches [millimeters]

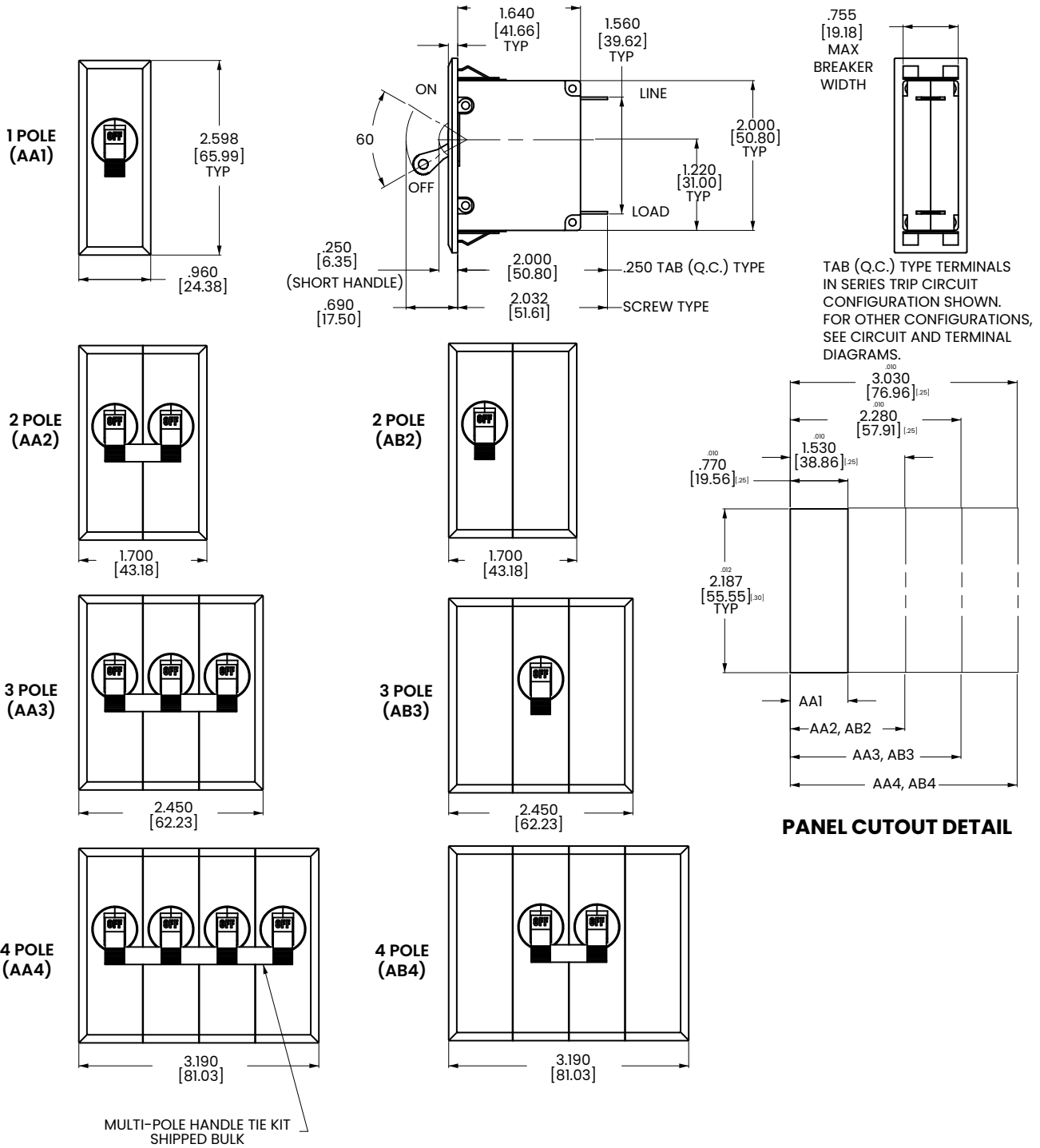

Notes:
 1 Recommended panel thickness: .040 [1.02] to .100 [2.54].
 2 Tolerance ±.020 [.51] unless otherwise specified.

Ordering Scheme

Sealed Toggle

Sample Part Number

A M 1 - B 0 - 10 - 450 - 1 0 1 - C

Selection

1 2 3 4 5 6 7 8 9 10 11

1. SERIES

A

2. ACTUATOR ¹

M Sealed Toggle, one per unit

3. POLES

1 One 2 Two 3 Three

4. CIRCUIT

A ² Switch Only (No Coil)	F ³ Relay Trip (Current)
B Series Trip (Current)	G ³ Relay Trip (Voltage)
C Series Trip (Voltage)	H ^{3,4} Dual Coil with Shunt Trip Voltage Coil
D ³ Shunt Trip (Current)	K ^{3,4} Dual Coil with Relay Trip Voltage Coil
E ³ Shunt Trip (Voltage)	

5. AUXILIARY / ALARM SWITCH ⁵

0 without Aux Switch	7 S.P.S.T., 0.110 Q.C. Term. (Gold Contacts)
1 S.P.D.T., 0.093 Q.C. Term.	8 S.P.S.T., 0.187 Q.C. Term.
2 S.P.D.T., 0.110 Q.C. Term.	9 S.P.D.T., 0.187 Q.C. Term.
5 S.P.S.T., 0.093 Q.C. Term. (Gold Contacts)	

6. FREQUENCY & DELAY

03 DC 50/60Hz, Switch Only	30 DC, 50/60Hz Instantaneous
10 DC Instantaneous	31 DC, 50/60Hz Ultra Short
11 DC Ultra Short	32 DC, 50/60Hz Short
12 DC Short	34 DC, 50/60Hz Medium
14 DC Medium	36 DC, 50/60Hz Long
16 DC Long	42 ⁷ 50/60Hz Short, High-inrush
20 50/60Hz Instantaneous	44 ⁷ 50/60Hz Medium, High-inrush
21 50/60Hz Ultra Short	46 ⁷ 50/60Hz Long, High-inrush
22 50/60Hz Short	52 ⁷ DC, Short, High-inrush
24 50/60Hz Medium	54 ⁷ DC, Medium, High-inrush
26 50/60Hz Long	56 ⁷ DC, Long, High-inrush

7. CURRENT RATING (AMPERES)

CODE	AMPERES						
020	0.020	230	0.300	425	2.500	612	12.000
025	0.025	235	0.350	527	2.750	712	12.500
030	0.030	240	0.400	430	3.000	613	13.000
035	0.035	245	0.450	435	3.500	614	14.000
040	0.040	250	0.500	440	4.000	615	15.000
045	0.045	255	0.550	445	4.500	616	16.000
050	0.050	260	0.600	450	5.000	617	17.000
055	0.055	265	0.650	455	5.500	618	18.000
060	0.060	270	0.700	460	6.000	620	20.000
065	0.065	275	0.750	465	6.500	622	22.000
070	0.070	280	0.800	470	7.000	624	24.000
075	0.075	285	0.850	475	7.500	625	25.000
080	0.080	290	0.900	480	8.000	630	30.000
085	0.085	295	0.950	485	8.500	635 ⁸	35.000
090	0.090	410	1.000	490	9.000	640 ⁸	40.000
095	0.095	512	1.250	495	9.500	645 ⁸	45.000
210	0.100	415	1.500	610	10.000	650 ⁸	50.000
215	0.150	517	1.750	710	10.500		
220	0.200	420	2.000	611	11.000		
225	0.250	522	2.250	711	11.500		

OR VOLTAGE COIL (NORMAL RATED VOLTAGE) ⁶

A06 6 DC	A32 32 DC	J12 12 AC	J65 65 AC
A12 12 DC	A48 48 DC	J18 18 AC	K20 120 AC
A18 18 DC	A65 65 DC	J24 24 AC	L40 240 AC
A24 24 DC	J06 6 AC	J48 48 AC	

8. TERMINAL ⁹

1 ¹⁰ Push-On 0.250 Tab (Q.C.)	C Screw, M4 with upturned lugs
2 Screw 8-32 with upturned lugs	E Screw M4 (Bus Type)
3 Screw 8-32 (Bus Type)	F Screw M5 with upturned lugs & 30° bend
4 Screw 10-32 with upturned lugs	G Screw M5 (Bus Type) & 30° bend
5 Screw 10-32 (Bus Type)	H Screw M5 (Bus Type)
6 Screw 8-32 with upturned lugs & 30° bend	L ¹² 0.250 Q.C./ Solder Lug
7 Screw 8-32 (Bus Type) & 30° bend	M M6 Threaded Stud
8 Screw 10-32 with upturned lugs & 30° bend	P ¹² Printed Circuit Board Terminals
9 Screw 10-32 (Bus Type) & 30° bend	Q Push-In Stud
B Screw M5 with upturned lugs	R Screw, M4 with upturned lugs & 30° Bend
	S ¹⁷ Push-On 0.110 Tab (Q.C.) & 30° bend
	T Screw, M4 with upturned lugs

9. LEGEND PLATE

0 No legend plate

10. MOUNTING / BARRIERS

	MOUNTING STYLE	BARRIERS
1	Standard Hex Nut	no
A	Standard Hex Nut (multipole only)	yes

11. AGENCY APPROVAL

C UL Recognized & CSA Accepted
 I UL Recognized STD 1077, UL Recognized 1500 (ignition protected), & CSA Accepted

Notes:

- Actuator Code M: Handle location as viewed from front of panel: 2 pole - right pole 3 pole - center pole
- Switch Only circuits, rated up to 50 amps and 3 poles. Only available when tied to a protected pole. For .02 to 30 amps, select Current Code 630. For 35 - 50 amps, select Current Code 650.
- Available with terminal Codes 1, 2 and 3. Current Rating limited to 30 amps maximum.
- Consult factory for available Dual Coil options, as special catalog number is required. With Shunt construction, Dual Coils will trip instantaneously on line volt age. Dual coils require 30VA minimum power to trip and are rated for intermittent duty only.
- Auxiliary Switch available on Series Trip & Switch Only circuits, limited to 30 amps. On multi-pole breakers, one auxiliary switch is supplied, mounted in the extreme right pole.
- Voltage coils not rated for continuous duty. Available only with delay codes 10 and 20.
- Available with Circuit Codes B & D only. VDE Certified to 30 amps. UL Recognized, CSA Accepted & TUV Certified to 50 amps.
- UL Recognition and CSA Certification available on one and two pole breakers.
- Screw Terminals are recommended on ratings greater than 20 amps. Ratings over 30 amps are only available with Terminal Codes 5, 9, B, F, G, H, M and Q.
- Terminal Code I: UL Recognition and CSA Certification up to 30 amps, but not recommended over 20 amps.
- Terminal Code L: available up to 30A.
- Single pole breakers with Terminal Code P (Printed Circuit Board) are available up to 50 amps, with Circuit Codes A, B and C. Two pole breakers with Terminal Code P (Printed Circuit Board) are available up to 40 amps with Circuit Codes A, B and C.

[Configure Complete Part Number >](#)

[Browse Standard Parts >](#)

Dimensional Specs Sealed Toggle

inches [millimeters]

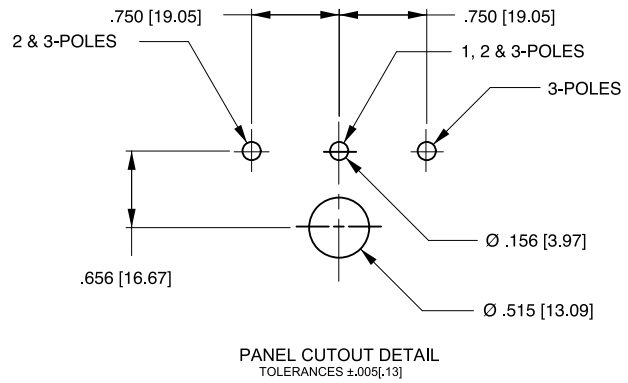
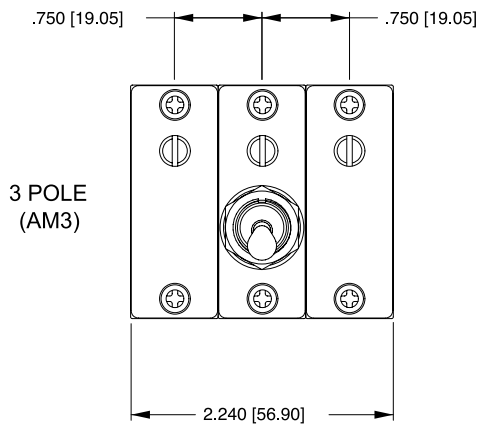
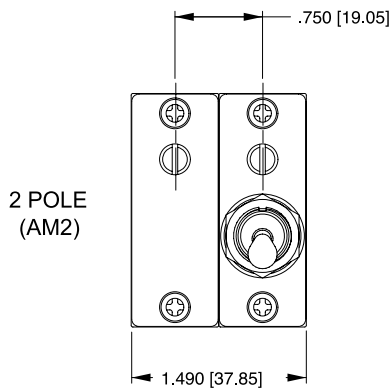
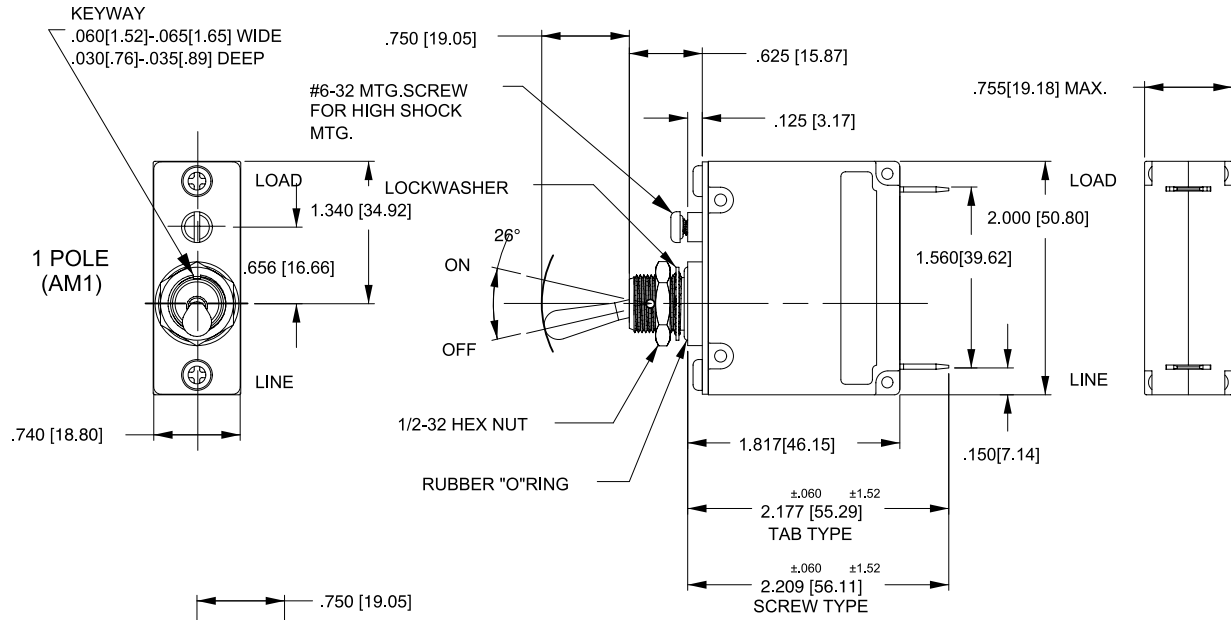

Notes:
 1 Tolerance ±.020 [.51] unless otherwise specified.

Ordering Scheme

Rocker UL 1077 Recognized

Sample Part Number

A F 1 - B 0 - 24-630 - 2 3 1 - D

Selection

1 2 3 4 5 6 7 8 9 10 11

1. SERIES

A

2. ACTUATOR ¹

Two Color Visi-Rocker

- C Indicate ON, vertical legend
- D Indicate ON, horizontal legend
- F Indicate OFF, vertical legend
- G Indicate OFF, horizontal legend
- H Indicate OFF, no legend

Push-To-Reset, Visi-Rocker

- N Indicate OFF, vertical legend
- O Indicate OFF, horizontal legend
- P Indicate OFF, no legend

Single color

- J Vertical legend
- K Horizontal legend
- L No legend

Push-To-Reset, Single color

- R Vertical legend
- U Horizontal legend
- V No legend

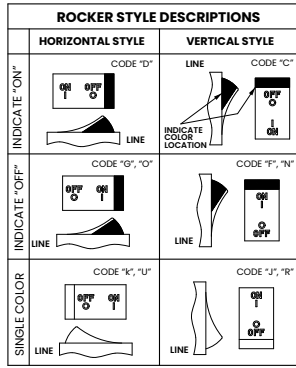

3. POLES

1 One 2 Two 3 Three

4. CIRCUIT

- A³ Switch Only (No Coil)
- B Series Trip (Current)
- C Series Trip (Voltage)
- D⁴ Shunt Trip (Current)
- E⁴ Shunt Trip (Voltage)
- G⁴ Relay Trip (Voltage)
- H^{4,5} Dual Coil with Shunt Trip Voltage Coil
- K^{4,5} Dual Coil with Relay Trip Voltage Coil

5. AUXILIARY / ALARM SWITCH ⁵

- 0 without Aux Switch
- 1 S.P.D.T., 0.093 Q.C. Term.
- 2 S.P.D.T., 0.110 Q.C. Term.
- 5 S.P.S.T., 0.093 Q.C. Term. (Gold Contacts)
- 7 S.P.S.T., 0.110 Q.C. Term. (Gold Contacts)
- 8 S.P.S.T., 0.187 Q.C. Term.
- 9 S.P.D.T., 0.187 Q.C. Term.

6. FREQUENCY & DELAY

- 03 DC 50/60Hz, Switch Only
- 10 DC Instantaneous
- 11 DC Ultra Short
- 12 DC Short
- 14 DC Medium
- 16 DC Long
- 20 50/60Hz Instantaneous
- 21 50/60Hz Ultra Short
- 22 50/60Hz Short
- 24 50/60Hz Medium
- 26 50/60Hz Long
- 30 DC, 50/60Hz Instantaneous
- 31 DC, 50/60Hz Ultra Short
- 32 DC, 50/60Hz Short
- 34 DC, 50/60Hz Medium
- 36 DC, 50/60Hz Long
- 42⁹ 50/60Hz Short, High-inrush
- 44⁹ 50/60Hz Medium, High-inrush
- 46⁹ 50/60Hz Long, High-inrush
- 52⁹ DC, Short, High-inrush
- 54⁹ DC, Medium, High-inrush
- 56⁹ DC, Long, High-inrush

7. CURRENT RATING (AMPERES)

CODE	AMPERES						
020	0.020	225	0.250	420	2.000	611	11.000
025	0.025	230	0.300	522	2.250	711	11.500
030	0.030	235	0.350	527	2.750	612	12.000
035	0.035	240	0.400	430	3.000	712	12.500
040	0.040	245	0.450	435	3.500	613	13.000
045	0.045	250	0.500	440	4.000	614	14.000
050	0.050	255	0.550	445	4.500	615	15.000
055	0.055	260	0.600	450	5.000	616	16.000
060	0.060	265	0.650	455	5.500	617	17.000
065	0.065	270	0.700	460	6.000	618	18.000
070	0.070	275	0.750	465	6.500	620	20.000
075	0.075	280	0.800	470	7.000	622	22.000
080	0.080	285	0.850	475	7.500	624	24.000
085	0.085	290	0.900	480	8.000	625	25.000
090	0.090	295	0.950	485	8.500	630	30.000
095	0.095	410	1.000	490	9.000	635 ⁸	35.000
210	0.100	512	1.250	495	9.500	640 ⁸	40.000
215	0.150	415	1.500	610	10.000	645 ⁸	45.000
220	0.200	517	1.750	710	10.500	650 ⁸	50.000

OR VOLTAGE COIL (NORMAL RATED VOLTAGE) ⁸

A06	6 DC	A32	32 DC	J12	12 AC	J65	65 AC
A12	12 DC	A48	48 DC	J18	18 AC	K20	120 AC
A18	18 DC	A65	65 DC	J24	24 AC	L40	240 AC
A24	24 DC	J06	6 AC	J48	48 AC		

8. TERMINAL ¹¹

- 1¹² Push-On 0.250 Tab (Q.C.)
- 2 Screw 8-32 with upturned lugs
- 3¹³ Screw 8-32 (Bus Type)
- 4 Screw 10-32 with upturned lugs
- 5¹³ Screw 10-32 (Bus Type)
- 6 Screw 8-32 with upturned lugs & 30° bend
- 7 Screw 8-32 (Bus Type)
- 8 Screw 10-32 with upturned lugs & 30° bend
- 9 Screw 10-32 (Bus Type) & 30° bend
- B Screw M5 with upturned lugs
- C Screw, M4 with upturned lugs
- E¹³ Screw M4 (Bus Type)
- F Screw M5 with upturned lugs & 30° bend
- G Screw M5 (Bus Type) & 30° bend
- H¹³ Screw M5 (Bus Type)
- L¹⁴ 0.250 Q.C./ Solder Lug
- M¹³ M6 Threaded Stud
- P¹⁵ Printed Circuit Board Terminals
- Q Push-In Stud
- R Screw, M4 with upturned lugs & 30° Bend
- S¹⁷ Push-On 0.110 Tab (Q.C.) & 30° bend
- T Screw, M4 with upturned lugs

9. ACTUATOR COLOR & LEGEND

Actuator or Visi-Color ¹²	Marking:			Marking Color	
	I-O	ON-OFF	Dual ¹²	Single Color	Visi-Rocker
White	A	B	1	Black	White
Black	C	D	2	White	n/a
Red	F	G	3	White	Red
Green	H	J	4	White	Green
Blue	K	L	5	White	Blue
Yellow	M	N	6	Black	Yellow
Gray	P	Q	7	Black	Gray
Orange	R	S	8	Black	Orange

10. MOUNTING / BARRIERS ²⁰

STANDARD ROCKER BEZEL Threaded Insert, 2 per pole	BARRIERS
1 6-32 x 0.195 inches	no
A 6-32 X 0.195 inches (multi-pole units only)	yes
2 ISO M3 x 5mm	no
B ISO M3 x 5mm (multi-pole units only)	yes
ROCKERGUARD & PUSH-TO-RESET BEZEL Threaded Insert, 2 per pole	
3 6-32 x 0.195 inches	no
C 6-32 x 0.195 inches (multi-pole units only)	yes
4 ISO M3 x 5mm	no
D ISO M3 x 5mm (multi-pole units only)	yes
FRONT PANEL SNAP-IN BRACKET, 0.744" [18.90mm] wide bezel	
8 without Rockerguard (single pole units only)	no
H with Rockerguard (single pole units only)	no
FRONT PANEL SNAP-IN BRACKET, 0.96" [24.48mm] wide bezel	
9 without Rockerguard (single pole units only)	no
J with Rockerguard (single pole units only)	no

11. AGENCY APPROVAL

- C UL Recognized & CSA Accepted
- D VDE Certified, UL Recognized & CSA Accepted
- E TUV Certified, UL Recognized & CSA Accepted
- I UL Recognized STD 1077, UL Recognized 1500 (ignition protected), & CSA Accepted

Notes:

- 1 Push-To-Reset actuators have OFF portion of rocker shrouded.
- 2 Multi-pole breakers have all breakers identical except when specifying Auxiliary switch and/or mixed poles, and have one rocker per breaker.
- 3 Switch Only circuits, rated up to 50 amps & 3 poles, are available only when tied to a protected pole (Circuit Code B, C, D or H). For .02 to 30 amps, select Current Code 630. For 35 - 50 amps, select Current Code 650.
- 4 Available with terminal Codes 1, 2 and 3. Current Rating limited to 30 amps maximum.
- 5 Consult factory for Dual Coil options, as special catalog number is required. With Shunt construction, Dual Coils will trip instantaneously on line voltage. Dual coils require 30VA minimum power to trip and are rated for intermittent duty only.
- 6 Auxiliary Switch breakers with Series Trip & Switch Only circuits: < 30A, are supplied with standard half shells. 30-50A are supplied with extended boat (B-Style) half shells.
- 7 On multi-pole breakers, one auxiliary switch is supplied, mounted in the right pole.
- 8 Separate pole type voltage coils not rated for continuous duty. Available only with delay codes 10 & 20.
- 9 Available with Circuit Codes B & D only. VDE Certified to 30 amps. UL Recognized, CSA Accepted & TUV Certified to 50 amps.
- 10 Series Trip current ratings: VDE Certification available with single pole breakers with DC Delay only. UL Recognition & CSA Accepted available in one and two pole breakers.
- 11 Screw Terminals are recommended on ratings greater than 20 amps. Ratings over 30 amps are only available with Terminal Codes 5, 9, G, H, M and Q.
- 12 Terminal Code I: VDE Certification up to 25 amps and UL Recognition and CSA Accepted up to 30 amps, but not recommended over 20 amps.
- 13 Terminal Codes 3, 5 E & H (Bus Type) with VDE, are supplied with Lock Washers; Terminal Code M (M6 Threaded Stud) with VDE is supplied with Lock and Flat Washers. These breakers are only VDE Certified when the washers are used.
- 14 VDE Cert. available up to 12 amps. UL Rec. & CSA Accepted available up to 30 amps.
- 15 Single pole breakers with Terminal Code P (Printed Circuit Board) are available up to 30 amps with VDE Certification and 50 amps with UL Recognition and CSA Accepted, with Circuit Codes A, B & C. Two pole breakers with Terminal Code P (Printed Circuit Board) are available up to 40 amps with UL Recognition and CSA Certification with Circuit Codes A, B and C.
- 16 Terminal Code Q not available with VDE.
- 17 Terminal Code S used on voltage coil circuit constructions only.
- 18 Color shown is visi and legend with remainder of rocker black.
- 19 Dual = ON-OFF/I-O legend with actuator. None = no legend on actuator
- 20 Legend on Push-to-reset bezel/shroud is white with single color actuator codes R, & U. Legend on Push-to-reset bezel/shroud matches Visi-color of rocker with actuator codes N & O. Rockerguard available with actuator codes C through L.

Ordering Scheme Rocker - UL 489A Listed

Sample Part Number **A F 1 - B 0 - 14-450 - 1 3 1 - M T**

Selection 1 2 3 4 5 6 7 8 9 10 11 12

1. SERIES

A

2. ACTUATOR ¹

- | | |
|--|--|
| Two Color Visi-Rocker | Push-To-Reset, Visi-Rocker |
| C Indicate ON, vertical legend | N Indicate OFF, vertical legend |
| D Indicate ON, horizontal legend | O Indicate OFF, horizontal legend |
| F Indicate OFF, vertical legend | O Indicate OFF, horizontal legend |
| G Indicate OFF, horizontal legend | U Horizontal legend |
| Single color | Push-To-Reset, Single color |
| J Vertical legend | R Vertical legend |
| K Horizontal legend | U Horizontal legend |

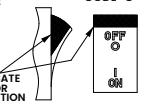
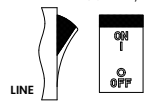
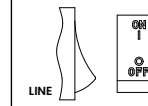
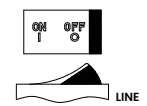
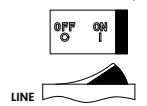
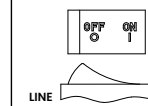
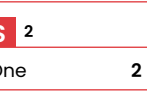
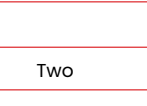
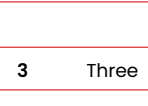
ROCKER STYLE DESCRIPTIONS			
	INDICATE "ON"	INDICATE "OFF"	SINGLE COLOR
VERTICAL STYLE	LINE  CODE "C"	LINE  CODE "F", "N"	LINE  CODE "J", "R"
	INDICATE COLOR LOCATION  CODE "D"	LINE  CODE "G", "O"	LINE  CODE "K", "U"
HORIZONTAL STYLE	LINE 	LINE 	LINE 

3. POLES ²

1 One 2 Two 3 Three

4. CIRCUIT

B Series Trip (Current)

5. AUXILIARY / ALARM SWITCH ²

- | | |
|---|---|
| 0 without Aux Switch | 7 S.P.S.T., 0.110 Q.C. Term. (Gold Contacts) |
| 1 S.P.D.T., 0.093 Q.C. Term. | 8 S.P.S.T., 0.187 Q.C. Term. |
| 2 S.P.D.T., 0.110 Q.C. Term. | 9 S.P.D.T., 0.187 Q.C. Term. |
| 5 S.P.S.T., 0.093 Q.C. Term. (Gold Contacts) | |

6. FREQUENCY & DELAY

- | | |
|--------------------------|-----------------------------------|
| 11 DC Ultra Short | 52 DC, Short, High-inrush |
| 12 DC Short | 54 DC, Medium, High-inrush |
| 14 DC Medium | 56 DC, Long, High-inrush |
| 16 DC Long | |

7. CURRENT RATING (AMPERES)

CODE	AMPERES				
210	0.100	285	0.850	455	5.500
215	0.150	290	0.900	460	6.000
220	0.200	295	0.950	465	6.500
225	0.250	410	1.000	470	7.000
230	0.300	512	1.250	475	7.500
235	0.350	415	1.500	480	8.000
240	0.400	517	1.750	485	8.500
245	0.450	420	2.000	490	9.000
250	0.500	522	2.250	495	9.500
255	0.550	527	2.750	610	10.000
260	0.600	430	3.000	710	10.500
265	0.650	435	3.500	611	11.000
270	0.700	440	4.000	711	11.500
275	0.750	445	4.500	612	12.000
280	0.800	450	5.000	712	12.500
				613	13.000
				614	14.000
				615	15.000
				616	16.000
				617	17.000
				618	18.000
				620	20.000
				622	22.000
				624	24.000
				625	25.000
				630	30.000
				635 ⁴	35.000
				640 ⁴	40.000
				645 ⁴	45.000
				650 ⁴	50.000

8. TERMINAL ⁵

- | | |
|---|--|
| 1⁶ Push-On 0.250 Tab (Q.C.) | 8 Screw 10-32 with upturned lugs & 30° bend |
| 2 Screw 8-32 with upturned lugs | 9 Screw 10-32 (Bus Type) & 30° bend |
| 3⁷ Screw 8-32 (Bus Type) | B Screw M5 with upturned lugs |
| 4 Screw 10-32 with upturned lugs | F Screw M5 with upturned lugs |
| 5⁷ Screw 10-32 (Bus Type) | G Screw M5 (Bus Type) & 30° bend |
| 6 Screw 8-32 with upturned lugs & 30° bend | H Screw M5 (Bus Type) |
| 7 Screw 8-32 (Bus Type) & 30° bend | M⁷ M6 Threaded Stud |
| | P⁸ Printed Circuit Board Terminals |
| | Q⁹ Push-In Stud |

9. ACTUATOR COLOR & LEGEND

Actuator or Visi-Color ¹⁰	Marking:		Marking Color	
	ON-OFF	Dual ¹⁰	Single Color	Visi-Rocker
White	B	1	Black	White
Black	D	2	White	n/a
Red	G	3	White	Red
Green	J	4	White	Green
Blue	L	5	White	Blue
Yellow	N	6	Black	Yellow
Gray	Q	7	Black	Gray
Orange	S	8	Black	Orange

10. MOUNTING / BARRIERS ²⁰

- | | |
|--|-----------------|
| STANDARD ROCKER BEZEL Threaded Insert, 2 per pole | BARRIERS |
| 1 6-32 x 0.195 inches | no |
| A 6-32 X 0.195 inches (multi-pole units only) | yes |
| 2 ISO M3 x 5mm | no |
| B ISO M3 x 5mm (multi-pole units only) | yes |
| ROCKERGUARD & PUSH-TO-RESET BEZEL Threaded Insert, 2 per pole | |
| 3 6-32 x 0.195 inches | no |
| C 6-32 x 0.195 inches (multi-pole units only) | yes |
| 4 ISO M3 x 5mm | no |
| D ISO M3 x 5mm (multi-pole units only) | yes |
| FRONT PANEL SNAP-IN BRACKET, 0.744" [18.90mm] wide bezel | |
| 8 without Rockerguard (single pole units only) | no |
| H with Rockerguard (single pole units only) | no |
| FRONT PANEL SNAP-IN BRACKET, 0.96" [24.48mm] wide bezel | |
| 9 without Rockerguard (single pole units only) | no |
| J with Rockerguard (single pole units only) | no |

11. MAXIMUM APPLICATION RATING

M 80 DC

12. AGENCY APPROVAL

- | | |
|----------|------------------------------|
| T | UL489A Listed |
| K | UL489A Listed, VDE Certified |
| J | UL489A Listed, TUV Certified |

Notes:

- Push-To-Reset actuators have OFF portion of rocker shrouded.
- Multi-pole breakers have all breakers identical except when specifying Auxiliary switch and/or mixed poles, and have one rocker per breaker.
- Auxiliary Switch breakers with Series Trip circuits: < 30A, are supplied with standard half shells. 30-50A are supplied with extended boat (B-Style) half shells.
- VDE Certification available with single pole breakers only. UL489A Listing available with one and two pole breakers.
- Screw Terminals are recommended on ratings greater than 20 amps. Ratings over 30 amps are only available with Terminal Codes 5, 9, G, H, M and Q.
- Terminal Code 1 (Push-On) available up to 25 amps with TUV or VDE Certification and 30 amps with UL489A Listing, but is not recommended over 20 amps.
- Terminal Codes 3, 5 and H (Bus Type) with TUV or VDE, are supplied with Lock Washers, and Terminal Code M (M6 Threaded Stud) with VDE is supplied with Lock and Flat Washers. These breakers are only TUV or VDE Certified when the washers are used.
- Single pole breakers with Terminal Code P (Printed Circuit Board) are available up to 30 amps with VDE Certification and 50 amps with UL489A Listing.
- Terminal Code Q not available with VDE certification.
- Color shown is Visi and Legend with remainder of rocker black. Dual = ON-OFF/-O legend.
- Legend on Push-to-reset bezel/shroud is white with single color actuator codes R & U. Legend on Push-To-Reset bezel/shroud matches Visi-Color of rocker with actuator codes N & O. Rockerguard available with actuator codes C through K

[Configure Complete Part Number >](#)

[Browse Standard Parts >](#)

Circuit & Terminal Diagrams

Rocker

inches [millimeters]

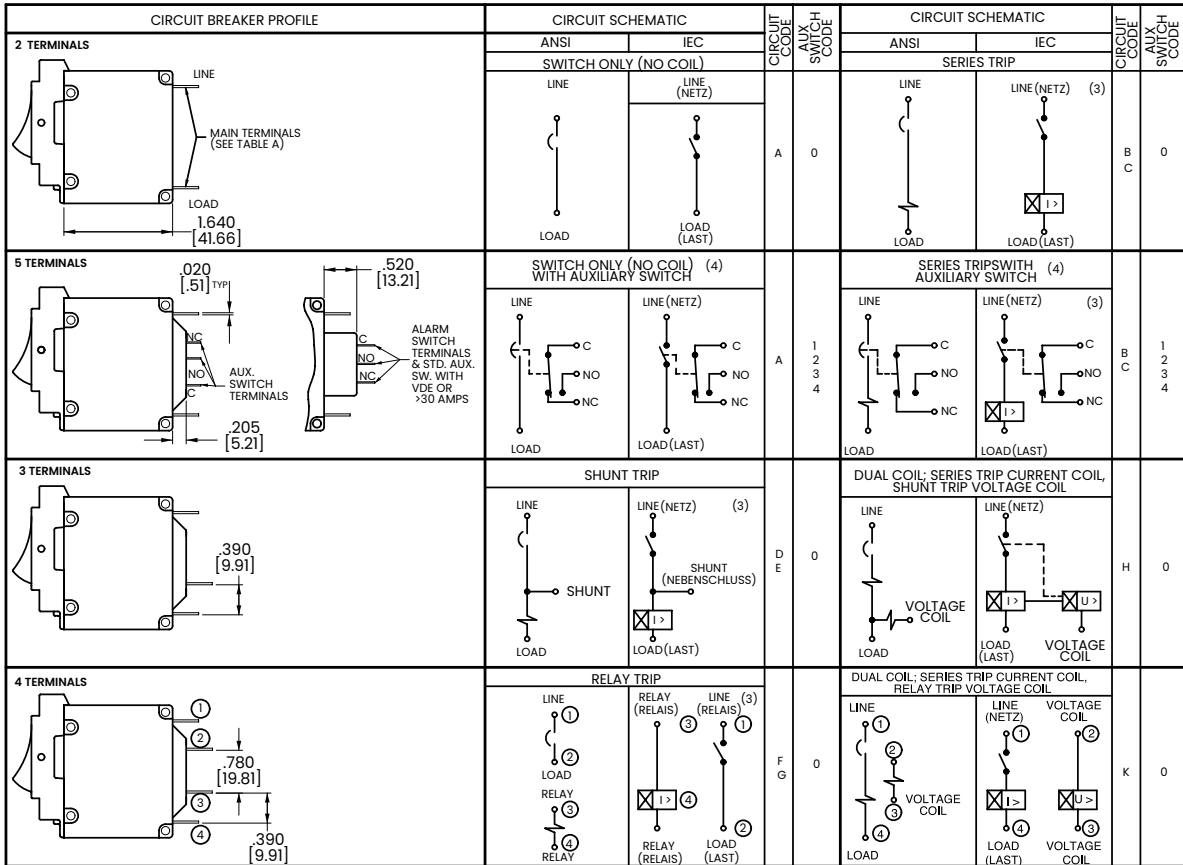

TERMINAL DESCRIPTION		DEPTH BEHIND PANEL
MAIN	TAB (Q.C.)	2.370 [60.20]
	SCREW TYPE	2.402 [61.01]
SHUNT, RELAY & DUAL COIL	TAB (Q.C.)	2.577 [65.46]
	SCREW #8-32 W/UPTURNED LUGS	2.734 [69.44]
AUX. SWITCH*	.093 TAB (Q.C.)	2.465 [62.61]
	.110 TAB (Q.C.) SOLDER TYPE	2.559 [65.00] 2.340 [59.44]

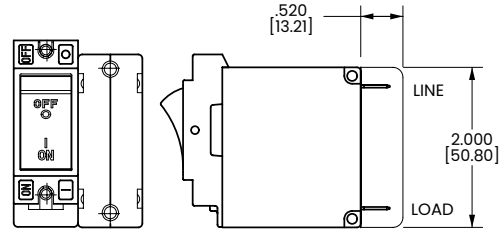

*AVAILABLE ON SERIES TRIP AND SWITCH ONLY CIRCUITS. WHEN CALLED FOR ON MULTI-POLE UNITS, ONLY ONE AUX. SWITCH IS NORMALLY SUPPLIED, AS SHOWN IN MULTI-POLE IDENTIFICATION SCHEME.

BARRIER FOR UL-RECOGNIZED MULTI-POLE BREAKERS

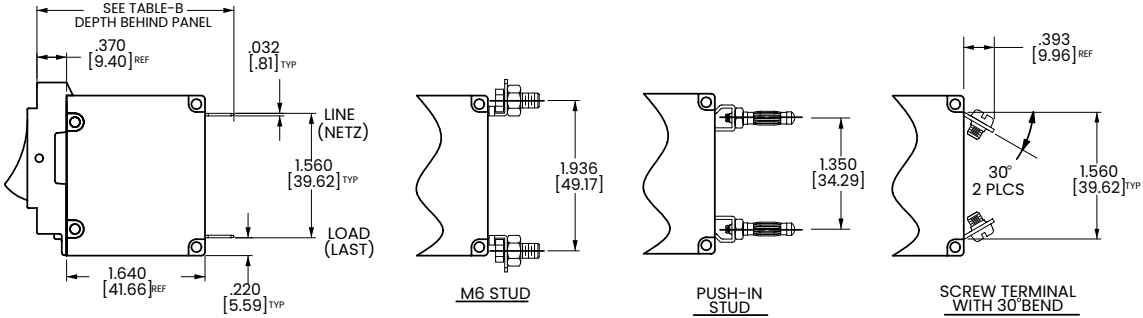

- Notes:
- 1 Tolerance ±.020 [.51] unless otherwise specified.
 - 2 Schematic shown represents current trip circuit.
 - 3 Circuits shown for >30 amps / VDE.

Dimensional Specs

Rocker

inches [millimeters]

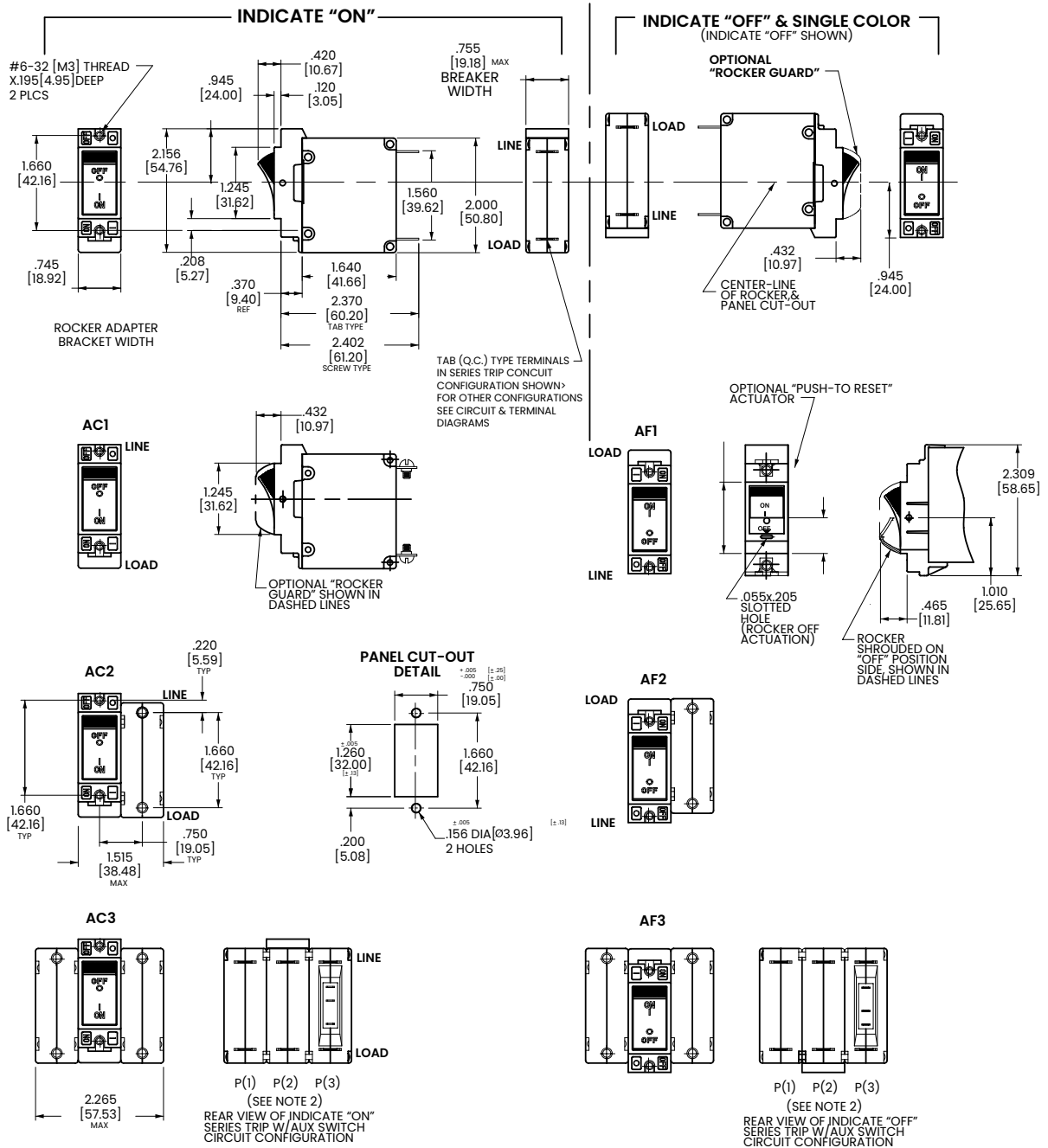

- Notes:
- Dimensions apply to all variations shown. Notice that circuit breaker line & load terminal orientation on indicate OFF is opposite of indicate ON.
 - For pole orientation with horizontal legend, rotate front view clockwise 90°.
 - Tolerance ± 0.20 [5.1] unless otherwise specified.

Dimensional Specs

Rocker Snap-In Bracket

inches [millimeters]

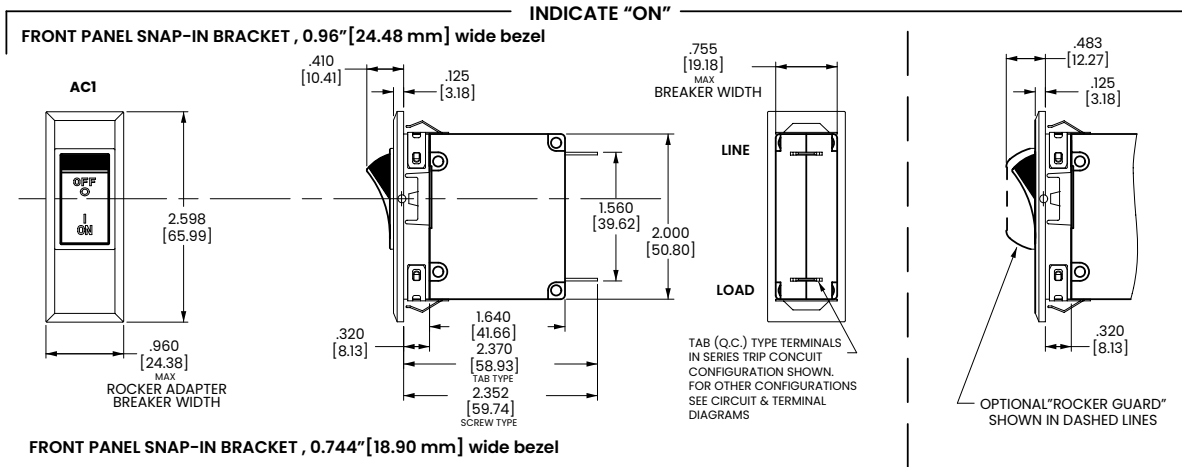

FRONT PANEL SNAP-IN BRACKET, 0.744" [18.90 mm] wide bezel

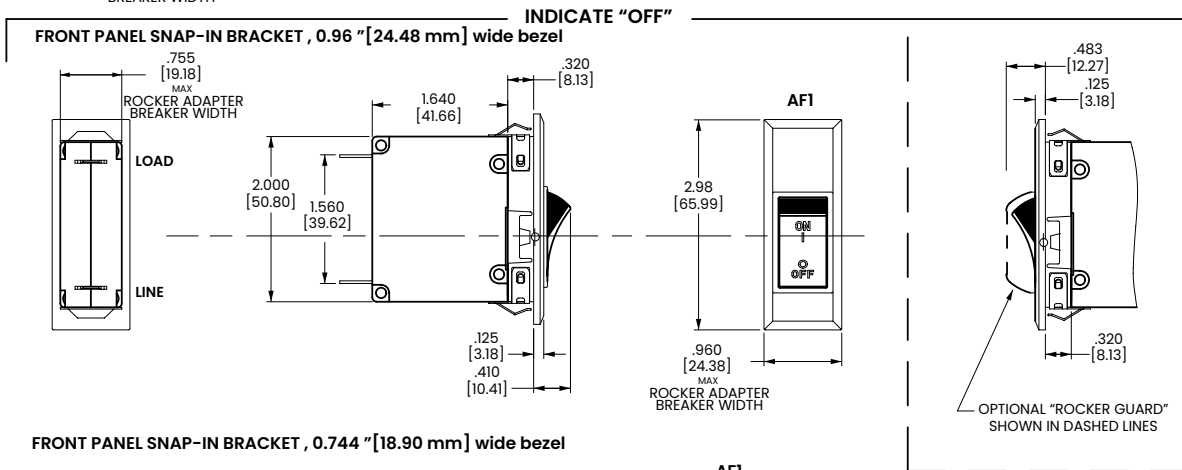
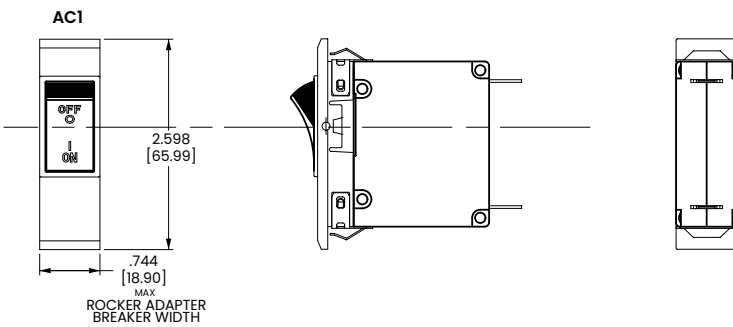

FRONT PANEL SNAP-IN BRACKET, 0.744" [18.90 mm] wide bezel

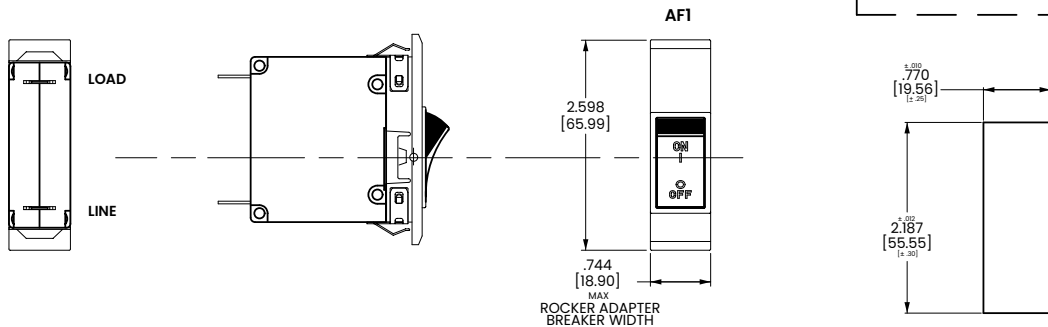

PANEL CUTOUT DETAIL

Notes:

- 1 Dimensions apply to all variations shown. Notice that circuit breaker line & load terminal
- 2 For pole orientation with horizontal legend, rotate front view clockwise 90°. Orientation on indicate "OFF" is opposite of indicate "ON"
- 3 Recommended panel thickness: .040 [1.02] to .100 [2.54]
- 4 Tolerance ±.020 [.51] unless otherwise specified.

PC Terminal Diagrams

inches [millimeters]

A-SERIES ROCKER

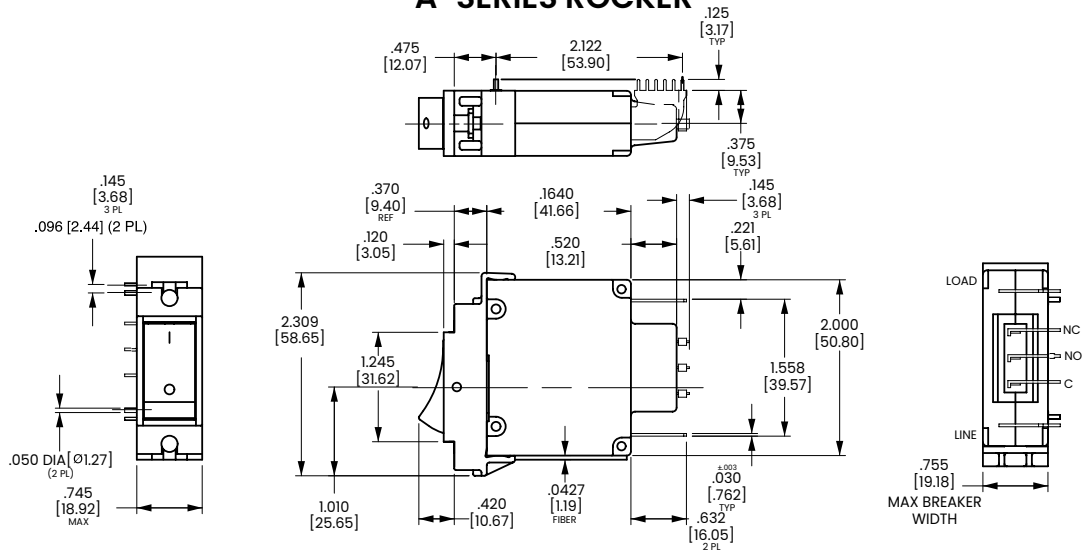

A-SERIES HANDLE

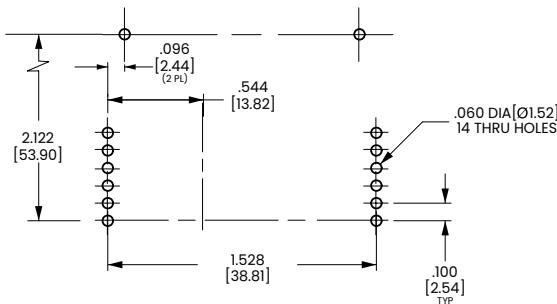
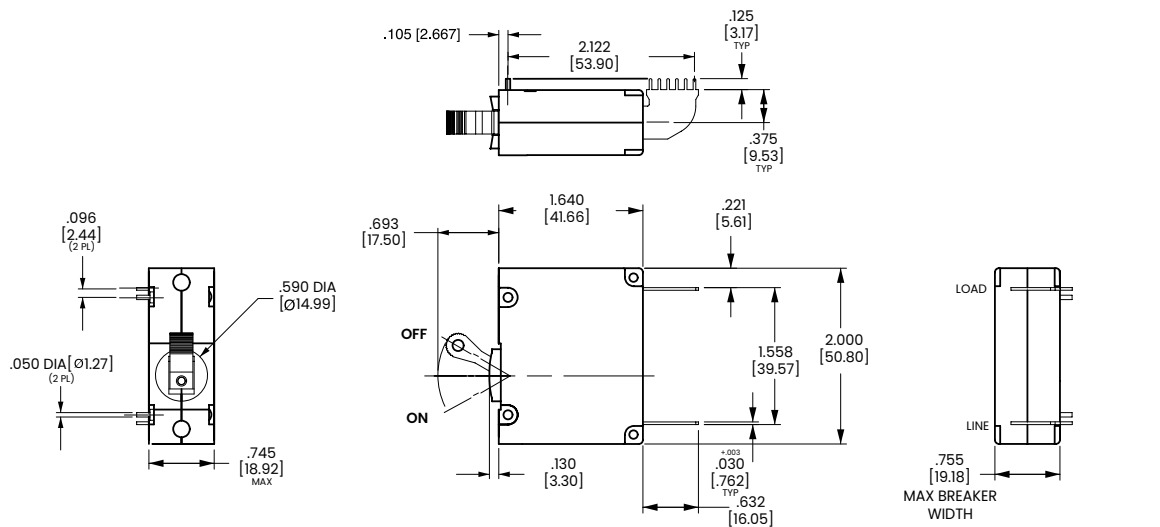

P.C. FOOT PRINT

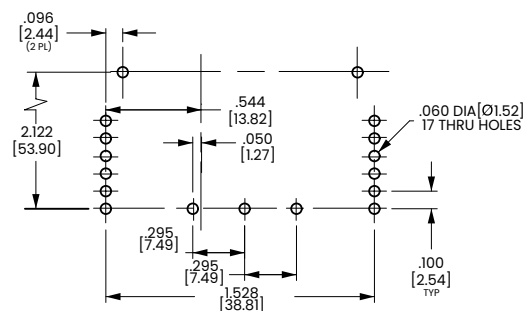

P.C. FOOT PRINT WITH AUX. SWITCH

- Notes:
- 1 Drawing illustrates A-Series with VDE certification.
 - 2 Tolerance ± 0.20 [.51] unless otherwise specified

Ordering Scheme

Flat Rocker - UL 1077 Recognized

Sample Part Number

A 1 1 - B 0 - 24-630 - 2 3 1 - E

Selection 1 2 3 4 5 6 7 8 9 10 11

1. SERIES

A

2. ACTUATOR 1

- Two Color Visi-Rocker**
 1 Indicate OFF, vertical legend
 2 Indicate OFF, horizontal legend
Single color
 3 Vertical legend
 4 Horizontal legend
Push-To-Reset, Visi-Rocker
 5 Indicate OFF, vertical legend
 6 Indicate OFF, horizontal legend
Push-To-Reset, Single color
 7 Vertical legend
 8 Horizontal legend

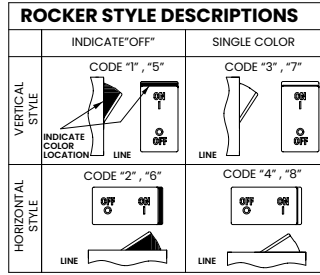

3. POLES 2

- 1 One 2 Two 3 Three

4. CIRCUIT

- A**³ Switch Only (No Coil) **G**⁴ Relay Trip (Voltage)
B Series Trip (Current) **H**^{4,5} Dual Coil with Shunt Trip
C Series Trip (Voltage) **K**^{4,5} Dual Coil with Relay Trip
D⁴ Shunt Trip (Current) Voltage Coil
E⁴ Shunt Trip (Voltage)
F⁴ Relay Trip (Current)

5. AUXILIARY / ALARM SWITCH 6,7

- 0** without Aux Switch **7** S.P.S.T., 0.110 Q.C. Term. (Gold Contacts)
1 S.P.D.T., 0.093 Q.C. Term. **8** S.P.S.T., 0.187 Q.C. Term.
2 S.P.D.T., 0.110 Q.C. Term. **9** S.P.D.T., 0.187 Q.C. Term. (Gold Contacts)
5 S.P.S.T., 0.093 Q.C. Term.

6. FREQUENCY & DELAY

- 03** DC 50/60Hz, Switch Only **31** DC, 50/60Hz Ultra Short
10⁶ DC Instantaneous **32** DC, 50/60Hz Short
11 DC Ultra Short **34** DC, 50/60Hz Medium
12 DC Short **36** DC, 50/60Hz Long
14 DC Medium **42**⁹ 50/60Hz Short, High-inrush
16 DC Long **44**⁹ 50/60Hz Medium, High-inrush
20⁶ 50/60Hz Instantaneous **46**⁹ 50/60Hz Long, High-inrush
21 50/60Hz Ultra Short **52**⁹ DC, Short, High-inrush
22 50/60Hz Short **54**⁹ DC, Medium, High-inrush
24 50/60Hz Medium **56** DC, Long, High-inrush
26 50/60Hz Long
30 DC, 50/60Hz Instantaneous

7. CURRENT RATING (AMPERES)

CODE	AMPERES						
020	0.020	225	0.250	420	2.000	611	11.000
025	0.025	230	0.300	522	2.250	711	11.500
030	0.030	235	0.350	527	2.750	612	12.000
035	0.035	240	0.400	430	3.000	712	12.500
040	0.040	245	0.450	435	3.500	613	13.000
045	0.045	250	0.500	440	4.000	614	14.000
050	0.050	255	0.550	445	4.500	615	15.000
055	0.055	260	0.600	450	5.000	616	16.000
060	0.060	265	0.650	455	5.500	617	17.000
065	0.065	270	0.700	460	6.000	618	18.000
070	0.070	275	0.750	465	6.500	620	20.000
075	0.075	280	0.800	470	7.000	622	22.000
080	0.080	285	0.850	475	7.500	624	24.000
085	0.085	290	0.900	480	8.000	625	25.000
090	0.090	295	0.950	485	8.500	630	30.000
095	0.095	410	1.000	490	9.000	635	35.000
210	0.100	512	1.250	495	9.500	640	40.000
215	0.150	415	1.500	610	10.000	645	45.000
220	0.200	517	1.750	710	10.500	650	50.000

OR VOLTAGE COIL (NORMAL RATED VOLTAGE) 8

A06	6 DC	A32	32 DC	J12	12 AC	J65	65 AC
A12	12 DC	A48	48 DC	J18	18 AC	K20	120 AC
A18	18 DC	A65	65 DC	J24	24 AC	L40	240 AC
A24	24 DC	J06	6 AC	J48	48 AC		

Configure Complete Part Number >

Browse Standard Parts >

8. TERMINAL 11

- 1**¹² Push-On 0.250 Tab (Q.C.) **C** Screw, M4 with upturned lugs
2 Screw 8-32 with upturned lugs **E**¹³ Screw M4 (Bus Type)
3¹³ Screw 8-32 (Bus Type) **F** Screw M5 with upturned lugs & 30° bend
4 Screw 10-32 with upturned lugs **G** Screw M5 (Bus Type) & 30° bend
5¹³ Screw 10-32 (Bus Type) **H**¹³ Screw M5 (Bus Type)
6 Screw 8-32 with upturned lugs & 30° bend **L**¹⁴ 0.250 Q.C./ Solder Lug
7 Screw 8-32 (Bus Type) **M**¹³ M6 Threaded Stud
8 Screw 10-32 with upturned lugs & 30° bend **P**¹⁵ Printed Circuit Board Terminals
9 Screw 10-32 (Bus Type) **Q** Push-In Stud
B Screw M5 with upturned lugs **R** Screw, M4 with upturned lugs & 30° Bend
S¹⁶ Push-On 0.110 Tab (Q.C.)
T Screw, M4 with upturned lugs

9. ACTUATOR COLOR & LEGEND

Actuator or Visi-Color ¹⁷	Marking:		Marking Color	
	ON-OFF	Dual ¹⁷	Single Color	Visi-Rocker
White	B	1	Black	White
Black	D	2	White	n/a
Red	G	3	White	Red
Green	J	4	White	Green
Blue	L	5	White	Blue
Yellow	N	6	Black	Yellow
Gray	Q	7	Black	Gray
Orange	S	8	Black	Orange

10. MOUNTING / BARRIERS 18

STANDARD ROCKER BEZEL Threaded Insert, 2 per pole BARRIERS

FLAT ROCKER ACTUATOR	
1 6-32 x 0.195 inches	no
A 6-32 x 0.195 inches (multi-pole units only)	yes
2 ISO M3 x 5mm	no
B ISO M3 x 5mm (multi-pole units only)	yes

RECESSED OFF SIDE ROCKER ACTUATOR 19

5 6-32 x 0.195 inches	no
E 6-32 x 0.195 inches (multi-pole units only)	yes
6 ISO M3 x 5mm	no
F ISO M3 x 5mm (multi-pole units only)	yes

PUSH-TO-RESET BEZEL, Threaded Insert, 2 per pole

3 6-32 x 0.195 inches	no
C 6-32 x 0.195 inches (multi-pole units only)	yes
4 ISO M3 x 5mm	no
D ISO M3 x 5mm (multi-pole units only)	yes

11. AGENCY APPROVAL

- C** UL Recognized & CSA Accepted
E TUV Certified, UL Recognized & CSA Accepted
I UL Recognized STD 1077, UL Recognized 1500 (ignition protected), & CSA Accepted

Notes:

- Push-To-Reset actuators have OFF portion of rocker shrouded.
- Multi-pole breakers have all breakers identical except when specifying Auxiliary switch and/or mixed poles, and have one rocker per breaker.
- Switch Only circuits, rated up to 50 amps & 3 poles. Only available when tied to a protected pole. For .02 to 30 amps, select Current Code 630. For 35 - 50 amps, select Current Code 650.
- Available with terminal Codes 1, 2 and 3. Current Rating limited to 30 amps maximum.
- Consult factory for Dual Coil options, as special catalog number is required. With Shunt construction, Dual Coils will trip instantaneously on line voltage. Dual coils require 30VA minimum power to trip and are rated for intermittent duty only.
- Auxiliary Switch breakers with Series Trip & Switch Only circuits: ≤ 30A, are supplied with standard half shells. 30-50A are supplied with extended boat (B-Style) half shells.
- On multi-pole breakers, one auxiliary switch is supplied, mounted in the extreme right pole.
- Separate pole type voltage coils not rated for continuous duty. Available only with delay codes 10 & 20.
- Available with Circuit Codes B & D only. UL Recognized, CSA Accepted & TUV Certified to 50 amps.
- UL Recognition, CSA Acceptance & TUV Certification available in one and two pole breakers.
- Screw Terminals are recommended on ratings greater than 20 amps. Ratings over 30 amps are only available with Terminal Codes 5, 9, G, H, M and Q.
- Terminal Code I: Available up to 30 amps, but not recommended over 20 amps.
- Terminal Codes 3, 5 E & H (Bus Type) with TUV, are supplied with Lock Washers; Terminal Code M (M6 Threaded Stud) with TUV is supplied with Lock and Flat Washers. These breakers are only TUV Certified when the washers are used.
- TUV Cert. available up to 12 amps. UL Rec. & CSA Accepted available up to 30 amps.
- Single pole breakers with Terminal Code P (Printed Circuit Board) are available up to 50 amps with UL Recognition, CSA Accepted & TUV Certification, with Circuit Codes A, B and C. Two pole breakers with Terminal Code P (Printed Circuit Board) are available up to 40 amps with UL Recognition and CSA Accepted with Circuit Codes A, B & C.
- Terminal Code S used on voltage coil circuit constructions only.
- Color shown is visi & legend with remainder of rocker black, Dual = ON-OFF/I-O legend.
- Legend on Push-to-reset bezel/shroud is white with single color actuator codes 7 & 8. Legend on Push-To-Reset bezel/shroud matches Visi-Color of rocker with actuator codes 5 & 6.
- Recessed "off-side" available with actuator codes 1, 2, 3 & 4. Legends on rocker are available in ink stamping only.

Ordering Scheme

Flat Rocker - UL 489A Listed

Sample Part Number

A 1 1 - B 0 - 14 - 630 - 2 3 1 - M T

Selection 1 2 3 4 5 6 7 8 9 10 11 12

1. SERIES

A

2. ACTUATOR ¹

- Two Color Visi-Rocker
- 1 Indicate OFF, vertical legend
- 2 Indicate OFF, horizontal legend
- Single color
- 3 Vertical legend
- 4 Horizontal legend
- Push-To-Reset, Visi-Rocker
- 5 Indicate OFF, vertical legend
- 6 Indicate OFF, horizontal legend
- Push-To-Reset, Single color
- 7 Vertical legend
- 8 Horizontal legend

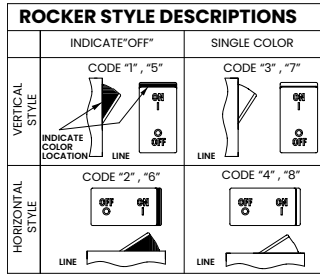

3. POLES ²

1 One 2 Two 3 Three

4. CIRCUIT

B Series Trip (Current)

5. AUXILIARY / ALARM SWITCH ³

0	without Aux Switch	7	S.P.S.T., 0.110 Q.C. Term. (Gold Contacts)
1	S.P.D.T., 0.093 Q.C. Term.	8	S.P.S.T., 0.187 Q.C. Term.
2	S.P.D.T., 0.110 Q.C. Term.	9	S.P.D.T., 0.187 Q.C. Term.

6. FREQUENCY & DELAY

11	DC Ultra Short	52	DC, Short, High-inrush
12	DC Short	54	DC, Medium, High-inrush
14	DC Medium	56	DC, Long, High-inrush
16	DC Long		

7. CURRENT RATING (AMPERES)

CODE	AMPERES						
020	0.020	225	0.250	420	2.000	611	11.000
025	0.025	230	0.300	522	2.250	711	11.500
030	0.030	235	0.350	527	2.750	612	12.000
035	0.035	240	0.400	430	3.000	712	12.500
040	0.040	245	0.450	435	3.500	613	13.000
045	0.045	250	0.500	440	4.000	614	14.000
050	0.050	255	0.550	445	4.500	615	15.000
055	0.055	260	0.600	450	5.000	616	16.000
060	0.060	265	0.650	455	5.500	617	17.000
065	0.065	270	0.700	460	6.000	618	18.000
070	0.070	275	0.750	465	6.500	620	20.000
075	0.075	280	0.800	470	7.000	622	22.000
080	0.080	285	0.850	475	7.500	624	24.000
085	0.085	290	0.900	480	8.000	625	25.000
090	0.090	295	0.950	485	8.500	630	30.000
095	0.095	410	1.000	490	9.000	635 ⁴	35.000
210	0.100	512	1.250	495	9.500	640 ⁴	40.000
215	0.150	415	1.500	610	10.000	645 ⁴	45.000
220	0.200	517	1.750	710	10.500	650 ⁴	50.000

8. TERMINAL ¹¹

2	Screw 8-32 with upturned lugs	9	Screw 10-32 (Bus Type) & 30° bend
3 7	Screw 8-32 (Bus Type)	B	Screw M5 with upturned lugs
4	Screw 10-32 with upturned lugs	F	Screw M5 with upturned lugs
5 7	Screw 10-32 (Bus Type)	G	Screw M5 (Bus Type) & 30° bend
6	Screw 8-32 with upturned lugs & 30° bend	H	Screw M5 (Bus Type)
8	Screw 10-32 with upturned lugs & 30° bend	M 7	M6 Threaded Stud
		P 8	Printed Circuit Board Terminals
		Q 9	Push-In Stud

9. ACTUATOR COLOR & LEGEND

Actuator or Visi-Color ¹¹	Marking:		Marking Color	
	ON-OFF	Dual ¹¹	Single Color	Visi-Rocker
White	B	1	Black	White
Black	D	2	White	n/a
Red	G	3	White	Red
Green	J	4	White	Green
Blue	L	5	White	Blue
Yellow	N	6	Black	Yellow
Gray	Q	7	Black	Gray
Orange	S	8	Black	Orange

10. MOUNTING / BARRIERS ¹²

	STANDARD ROCKER BEZEL Threaded Insert, 2 per pole FLAT ROCKER ACTUATOR	BARRIERS
1	6-32 x 0.195 inches	no
A	6-32 x 0.195 inches (multi-pole units only)	yes
2	ISO M3 x 5mm	no
B	ISO M3 x 5mm (multi-pole units only)	yes
	RECESSED OFF SIDE ROCKER ACTUATOR	
5	6-32 x 0.195 inches	no
E	6-32 x 0.195 inches (multi-pole units only)	yes
6	ISO M3 x 5mm	no
F	ISO M3 x 5mm (multi-pole units only)	yes
	PUSH-TO-RESET BEZEL, Threaded Insert, 2 per pole	
3	6-32 x 0.195 inches	no
C	6-32 x 0.195 inches (multi-pole units only)	yes
4	ISO M3 x 5mm	no
D	ISO M3 x 5mm (multi-pole units only)	yes

11. MAXIMUM APPLICATION RATING

M 80 DC

12. AGENCY APPROVAL

T UL489A Listed
J UL489A Listed, TUV Certified

Notes:

- 1 Push-To-Reset actuators have OFF portion of rocker shrouded.
- 2 Multi-pole breakers have all breakers identical except when specifying Auxiliary switch and/or mixed poles, and have one rocker per breaker.
- 3 Auxiliary Switch breakers with Series Trip circuits: ≤ 30A, are supplied with standard half shells. 30-50A are supplied with extended boat (B-Style) half shells.
- 4 VDE Certification available with single pole breakers only. UL489A Listing available with one and two pole breakers.
- 5 Screw Terminals are recommended on ratings greater than 20 amps. Ratings over 30 amps are only available with Terminal Codes 5, 9, G, H, M and Q.
- 6 Terminal Code 1 (Push-On) available up to 25 amps with TUV or VDE Certification and 30 amps with UL489A listing, but is not recommended over 20 amps.
- 7 Terminal Codes 3, 5 and H (Bus Type) with TUV or VDE, are supplied with Lock Washers, and Terminal Code M (M6 Threaded Stud) with VDE is supplied with Lock and Flat Washers. These breakers are only TUV or VDE Certified when the washers are used.
- 8 Single pole breakers with Terminal Code P (Printed Circuit Board) are available up to 30 amps with VDE Certification and 50 amps with UL489A Listing.
- 9 Terminal Code Q not available with VDE certification.
- 10 Color shown is Visi and Legend with remainder of rocker black. Dual = ON-OFF/I-O legend.
- 11 Legend on Push-to-reset bezel/shroud is white with single color actuator codes R & U.
- 12 Legend on Push-To-Reset bezel/shroud matches Visi-Color of rocker with actuator codes N & O. Rockerguard available with actuator codes C through K

[Configure Complete Part Number >](#)

[Browse Standard Parts >](#)

Dimensional Specs Flat Rocker

inches [millimeters]

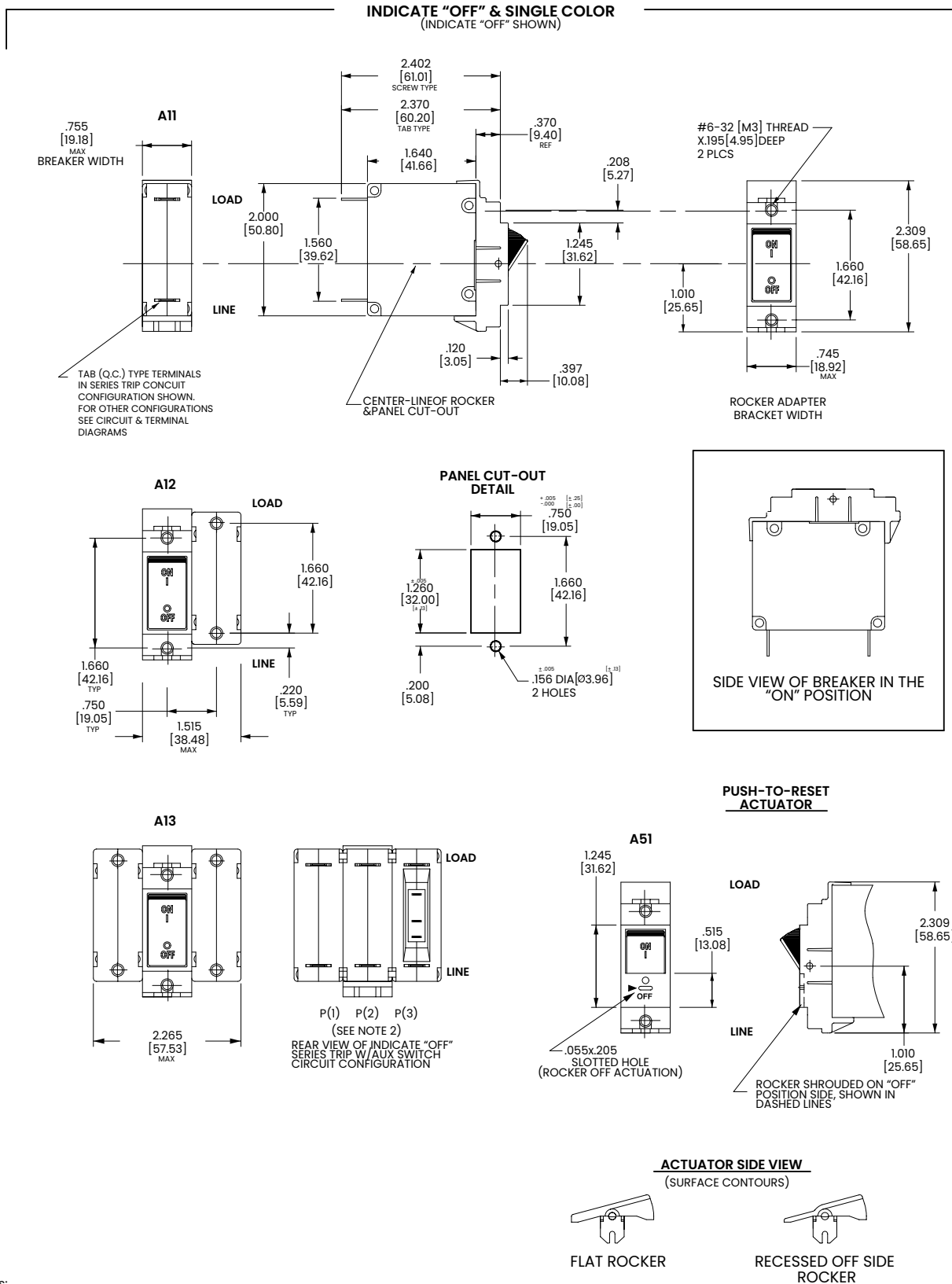

- Notes:
 1 For pole orientation with horizontal legend, rotate front view clockwise 90°.
 2 Tolerance ± 0.20 [5.1] unless otherwise specified.

Ordering Scheme Recessed Paddle

Sample Part Number

A Y 1 - B 0 - 14 - 630 - 2 3 1 - M T

Selection 1 2 3 4 5 6 7 8 9 10 11 12

1. SERIES

A

2. ACTUATOR ¹

Y Single Color Recessed Paddle Actuator with Vertical Legends

3. POLES ²

1 One **2** Two **3** Three

4. CIRCUIT

A Switch-Only (No Coil) **F** Relay Trip (Current)
B Series Trip (Current) **G** Relay Trip (Voltage)
C Series Trip (Voltage) **H** Dual Coil with Shunt Trip Voltage Coil
D Shunt Trip (Current) **K** Dual Coil with Shunt Trip Current Coil
E Shunt Trip (Voltage)

5. AUXILIARY SWITCH

0 without Aux Switch
1 S.P.D.T. with 0.093 Q.C. Terminals
2 S.P.D.T. with 0.110 Q.C. Terminals
3 S.P.D.T. with 0.139 Solder Lug Terminals
5 S.P.D.T. with 0.093 Q.C. Terminals (Gold Contacts)
6 S.P.S.T.-N.O. with 0.139 Solder Lug Terminals
7 S.P.S.T.-N.O. with 0.110 Q.C. Terminals (Gold Contacts)
8 S.P.S.T.-N.O. with 0.187 Q.C. Terminals
9 S.P.D.T. with 0.187 Q.C. Terminals

6. FREQUENCY & DELAY ³

3 DC, 50/60 Hz Switch Only	24 50/60 Hz Medium
10 DC Instantaneous	26 50/60 Hz Long
11 DC Ultra Short	42 50/60 Hz Short High-inrush
12 DC Short	44 50/60 Hz Medium High-inrush
14 DC Medium	46 50/60 Hz Long High-inrush
16 DC Long	52 DC, Short, High-inrush
20 50/60 Hz Instantaneous	54 DC, Medium, High-inrush
21 50/60 Hz Ultra Short	56 DC, Long, High-inrush
22 50/60 Hz Short	

7. CURRENT RATING (AMPERES) ⁴

CODE	AMPERES						
020	0.020	225	0.250	420	2.000	611	11.000
025	0.025	230	0.300	522	2.250	711	11.500
030	0.030	235	0.350	527	2.750	612	12.000
035	0.035	240	0.400	430	3.000	712	12.500
040	0.040	245	0.450	435	3.500	613	13.000
045	0.045	250	0.500	440	4.000	614	14.000
050	0.050	255	0.550	445	4.500	615	15.000
055	0.055	260	0.600	450	5.000	616	16.000
060	0.060	265	0.650	455	5.500	617	17.000
065	0.065	270	0.700	460	6.000	618	18.000
070	0.070	275	0.750	465	6.500	620	20.000
075	0.075	280	0.800	470	7.000	622	22.000
080	0.080	285	0.850	475	7.500	624	24.000
085	0.085	290	0.900	480	8.000	625	25.000
090	0.090	295	0.950	485	8.500	630	30.000
095	0.095	410	1.000	490	9.000	635	35.000
210	0.100	512	1.250	495	9.500	640	40.000
215	0.150	415	1.500	610	10.000	645	45.000
220	0.200	517	1.750	710	10.500	650	50.000

OR VOLTAGE COIL (NORMAL RATED VOLTAGE)

A06 6 DC	A32 32 DC	J12 12 AC	J65 65 AC
A12 12 DC	A48 48 DC	J18 18 AC	K20 120 AC
A18 18 DC	A65 65 DC	J24 24 AC	L40 240 AC
A24 24 DC	J06 6 AC	J48 48 AC	

8. TERMINAL

1 Push-On 0.250 Tab (Q.C.)	B Screw M5 with upturned lugs
2 Screw 8-32 with upturned lugs	C Screw, M4 with upturned lugs
3 7 Screw 8-32 (Bus Type)	F Screw M5 with upturned lugs
4 Screw 10-32 with upturned lugs	G Screw M5 (Bus Type) & 30° bend
5 7 Screw 10-32 (Bus Type)	H Screw M5 (Bus Type)
6 Screw 8-32 with upturned lugs & 30° bend	M M6 Threaded Stud
7 Screw 8-32 (Bus Type) & 30° bend	P Printed Circuit Board Terminals
8 Screw 10-32 with upturned lugs & 30° bend	Q Push-In Stud
9 Screw 10-32 (Bus Type) & 30° bend	R Screw, M4 with upturned lugs & 30° Bend
	S Screw, M5 with upturned lugs
	T Screw, M4 with upturned lugs

9. ACTUATOR COLOR & LEGEND ⁵

Actuator Color	I-O	ON-OFF	Dual	Legend Color
White	A	B	1	Black
Black	C	D	2	White
Red	F	G	3	White
Green	H	J	4	White
Blue	K	L	5	White
Yellow	M	N	6	Black
Gray	P	Q	7	Black
Orange	R	S	8	Black

10. MOUNTING / BARRIERS

		BARRIERS
1	6-32 x 0.195 inches	no
A	6-32 x 0.195 inches (multi-pole units only)	yes
2	ISO M3 x 5mm	no
B	ISO M3 x 5mm (multi-pole units only)	yes

11. MAXIMUM APPLICATION RATING ⁶

A 65 VDC
C 120/240 VAC (Available only on 2 or 3-Pole units)
K 120 VAC
M 80 DC

12. AGENCY APPROVAL ⁷

A Without Approvals
C UL Recognized and CSA Accepted
T UL 489A

Notes:

- All standard catalog numbers are supplied with Vertical Legends. For Horizontal or other non-standard legends, choose "X" and order as a special catalog number.
- For rating (T) 2 & 3 Pole not available.
- Frequency and Time Delay ratings of (03, 20, 21, 22, 24, 26, 42, 44, 46) not available with approval T.
- Voltage Coil Ratings starting with (J, K, or L) not available with approval T.
- "OFF" and/or "O" Legends are on Bracket and are only visible when the Paddle Actuator is in the off position.
- Maximum Application Ratings (C & K) not available with approval T.
- Not all approvals are available in all constructions. Consult factory for details.

[Configure Complete Part Number >](#)

[Browse Standard Parts >](#)

Dimensional Specs Recessed Paddle

inches [millimeters]

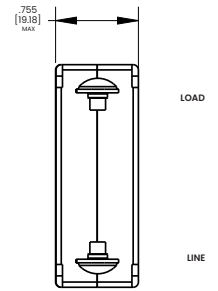
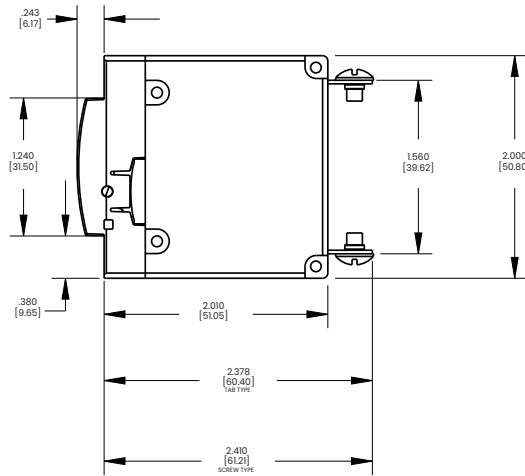
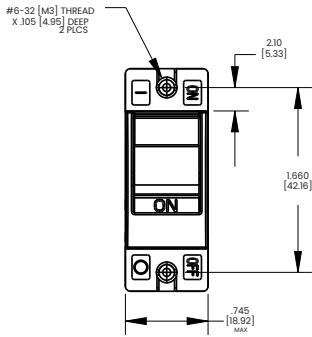

BREAKER SHOWN IN THE OFF POSITION

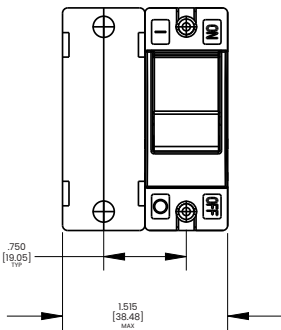

BREAKER SHOWN IN THE OFF POSITION

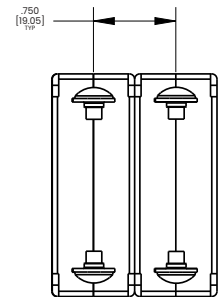
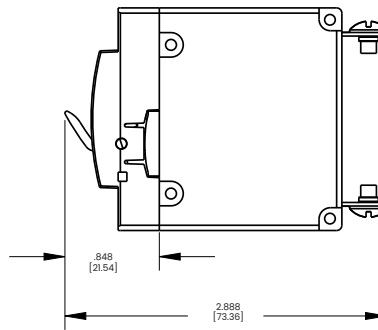

PANEL CUT-OUT DETAIL

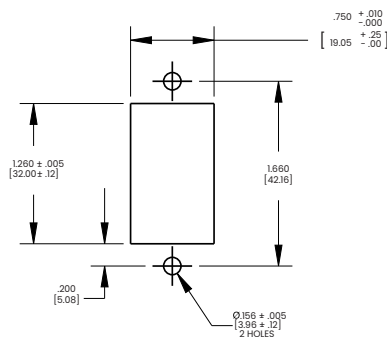
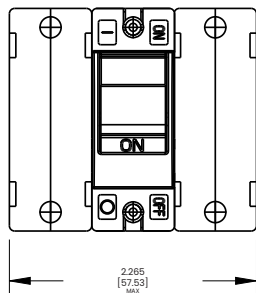

Notes:
1 Tolerance ± 0.20 [.51] unless otherwise specified

B-Series

Hydraulic-Magnetic Circuit Breaker

PRODUCT WEBPAGE

request sample, configure part



Global Regulatory Safety Compliant

The B-Series hydraulic-magnetic circuit breakers are an optimal choice for both general purpose and full amp loads. These versatile breakers offer global regulatory safety approvals, a wide choice of actuator styles, time delays, terminals and imprinting options. The B-Series is configurable in one to six poles, rated up to 50 amps and 277VAC or 80VDC, with a max IC of 7,500 amps.

1-6	50	277	80
Poles	Amps Max	VAC Max	VDC Max

Typical Applications

- Power Supplies
- Generators & Welders
- Control Panels
- Marine
- Industrial Automation
- Medical Equipment
- Office Equipment
- Datacom/Telecom
- Military
- Commercial Food

Tech Specs

Electrical

Maximum Voltage	277VAC 50/60 Hz, 80VDC
Current Ratings	Standard current coils: 0.100, 0.250, 0.500, 0.750, 1.00, 2.50, 5.00, 7.50, 10.0, 15.0, 20.0, 25.0, 30.0, 35.0, 40.0 and 50.0 amps. Other ratings available, see ordering scheme.
Standard Voltage Coils	DC - 6V, 12V; AC - 120V, other ratings available, see ordering scheme.
Auxiliary Switch Rating	SPDT; 10.1 AMPS - 250VAC, 1.0A 65 VDC or 0.5A 80 VDC, 0.1 Amps - 125VAC (with gold contacts). VDE-1.0 Amp/25VAC.
Insulation Resistance	Minimum of 100 Megohms at 500 VDC.
Dielectric Strength	UL, CSA-1500 V 50/60 Hz for one minute between all electrically isolated terminals. B-Series circuit breakers comply with the 8mm spacing and 3750V 50/60 Hz dielectric requirements from hazardous voltage to operator accessible surfaces, between adjacent poles and from main circuits to auxiliary circuits per Publications EN 60950 and VDE 0805.
Resistance, Impedance	Values from Line to Load Terminal - based on Series Trip Circuit Breaker.

RESISTANCE PER POLE VALUES from Line to Load Terminals (Values Based on Series Trip Circuit Breaker)

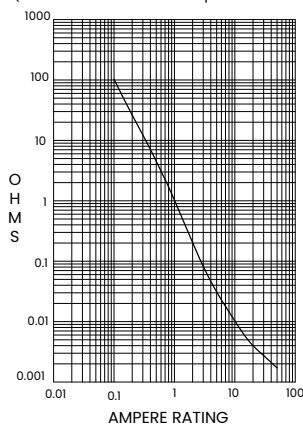

CURRENT (AMPS)	TOLERANCE (%)
0.10 - 5.0	15
5.1 - 20.0	25
20.1 - 50.0	35

Pulse Tolerance Curves

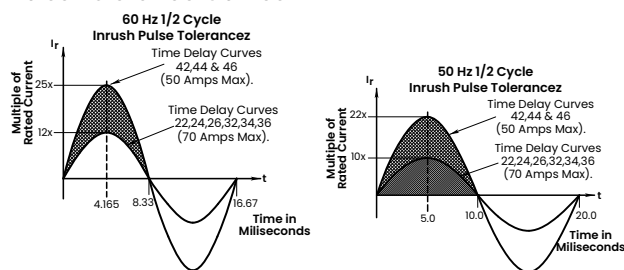

Mechanical

Endurance	10,000 ON-OFF operations @ 6 per minute; with rated Current & Voltage.
Trip Free	All B-Series Circuit Breakers will trip on overload, even when Handle is forcibly held in the ON position.
Trip Indication	The operating Handle moves positively to the OFF position when an overload causes the breaker to trip.
Number of Poles	1 - 6 poles at 30 Amps or less. 1 and 2 poles at 31 Amps thru 50 Amps.
Internal Circuit Config.	Series, (with or without auxiliary switch), Shunt and Relay with current or voltage trip coils, Dual Coil, Switch Only (with or without auxiliary switch).
Weight	Approximately 65 grams/pole.
Standard Colors	Housing- Black; Actuator - See Ordering Scheme.

Physical

Environmental

Designed and tested in accordance with requirements of specification MIL-PRF-55629 & MIL-STD-202 as follows:

Shock	Withstands 100 Gs, 6ms, sawtooth while carrying rated current per Method 213, Test Condition "I". Instantaneous and ultra-short curves tested @ 90% of rated current.
Vibration	Withstands 0.060" excursion from 10-55 Hz, and 10 Gs 55-500 Hz, at rated current per Method 204C, Test Condition A. Instantaneous and ultrashort curves tested at 90% of rated current.
Moisture Resistance	Method 106D, i.e., ten 24-hour cycles @ +25°C to +65°C, 80-98% RH.
Salt Spray	Method 101, Condition A (90-95% RH @ 5% NaCl Solution, 96 hrs).
Thermal Shock	Method 107D, Condition A (Five cycles @ -55°C to +25°C to +85°C to +25°C).
Operating Temperature	-40° C to +85° C

Tech Specs

Tables

Table A: Lists UL Recognized & CSA Certified configurations and performance capabilities as a Component Supplementary Protector.

Component Supplementary Protectors														
Circuit Configuration	Voltage			Current Rating		Short Circuit Capacity (Amps)		Application Codes		Construction Notes				
	Max Rating	Frequency	Phase	Full Load Amps	General Purpose Amps	UL/CSA		UL	CSA					
						With Backup Fuse	Without Backup Fuse							
Series	65	DC	-	31-50	-	-	-	7500	TC1,2, OL1,U1	TC1,2, OL1,U1				
	80			0.02-30					TC1,2, OL1,U1	TC1,2, OL1,U1				
				-					31-50	TC1,2, OL0,U1	TC1,2, OL1,U1			
	125	50/60	1	1-50	-			2000	TC1, OL1,U2	TC1, OL1,U2				
			1 ⁴					1000	TC1, OL1,U2	TC1, OL1,U3				
	125/250		1 ³	0.02-30				3000	TC1,2, OL1,U1	TC1,2, OL1,U1				
			1					1500	TC1, OL0,U2	TC1, OL0,U2	Single Pole Breaker			
	250		1	-				31-50	3000	TC1, OL1,U2	TC1, OL1,U2	Two Pole Break		
				1 ⁴				1-50	1000	TC1, OL1, U2	TC3, OL1,U3			
				3				0.02-30	5000 ²	TC1,2, OL1,C1	TC1,2, OL1,C1			
				-				31-50		2000 ¹	TC1,2, OL1, C1	TC1,2, OL1,C1		
				1				-		5000 ¹	TC1,2, OL1,C1	TC1,2, OL1,C1		
	277		1	0.02-30				-	-	7500	TC1,2, OL1,U1	TC1,2, OL1,U1		
80	DC	-	-	31-50	TC1,2, OL1,U1	TC1,2, OL1,U1								
			-	31-50	TC1,2, OL0,U1	TC1,2, OL0,U1								
125			50/60	1	1-50	2000	TC1, OL1,U2				TC1, OL1,U2			
125/250	1 ³	0.02-30		3000	TC1,2, OL1,U1	TC1,2, OL1,U1								
250	1	0.02-30		0.02-30	1500	TC1, OL0,U2	TC1, OL0,U2				Single Pole Breaker			
		0.02-30			3000	TC1, OL1,U2	TC1, OL1,U2				Two Pole Break			
		-		31-50	1000	TC1,2, OL0,U2	TC1,2, OL0,U2							
		1 ⁴		1-50	5000 ³	TC1,2, OL1,C1	TC1,2, OL1,C1							
		3		0.20-30	2000 ¹	TC1,2, OL1,C1	TC1,2, OL1,C1							
277	1	31-50		5000 ¹	TC1,2, OL1,U1	TC1,2, OL1,U1								
Shunt	80	DC		-	0.02-30	-	-				7500	TC1,2, OL1,U1	TC1,2, OL1,U1	
	125/250											1 ³	3000	TC1,2, OL1,U1
	250	50/60	1	TC1,2, OL1,U1				TC1,2, OL1,U1						
			3	5000 ²				TC1,2, OL1,U1	TC1,2, OL1,U1					
			1	5000 ¹				TC1,2, OL1,U1	TC1,2, OL1,U1					
277	1	-	5000 ¹	TC1,2, OL1,U1			TC1,2, OL1,U1							
Relay	80	DC	-	0.02-30			-	-	7500	TC1,2, OL1,U1	TC1,2, OL1,U1			
	125/250									1 ³	3000	TC1,2, OL1,U1	TC1,2, OL1,U1	
	250	50/60	1							TC1,2, OL1,U1		TC1,2, OL1,U1		
			3							5000 ²		TC1,2, OL1,U1	TC1,2, OL1,U1	
			1							5000 ¹	TC1,2, OL1,U1	TC1,2, OL1,U1		
277	1	-	5000 ¹					TC1,2, OL1,C1	TC1,2, OL1,C1					
Switch Only	65	DC	-					0.02-30	-	-	-	-	-	
	80				50/60	1								31-50
	250	3	-											
		277	1			31-50								

Notes:

- Requires branch circuit backup with a UL LISTED Type K5 or RK5 fuse (15A minimum) at no more than 4 times the rating of the protector.
- Same as note 1, except that backup fuse is limited to 80A maximum.
- 2 pole protector required (with one pole per power line) for: 250/125 VAC, 125/250 VAC and 208Y/120 VAC Power Systems. 1 pole protector required for : 125 VAC, 1Ø Power System.
- Satisfies the requirements of clause 11.2.8.2.5 of CSA STD C22.2 No 100 for the use of supplementary protectors with portable generators.

Tech Specs

Tables

Table B: Lists UL Recognized, CSA, VDE & TUV Certified configurations & performance capabilities as a Component Supplementary Protector.

Component Supplementary Protectors																		
Circuit Configuration	Voltage			Current Rating		Short Circuit Capacity (Amps)						Application Codes		Construction Notes				
	Max Rating	Frequency	Phase	Full Load Amps	General Purpose Amps ¹	UL/CSA		VDE		TUV		UL	CSA					
						With Backup Fuse	Without Backup Fuse	(Inc) With Backup Fuse	(Inc) Without Backup	(Inc) with Backup Fuse	(Inc) Without Backup							
Series	80	DC	-	0.10-30	-	-	7500	3000	1500	3000	1500	TC1,2, OL1,U1	TC1,2, OL1,U1					
				31-50	31-50							TC1,2, OL0,U1	TC1,2, OL0,U1					
				0.10-30	-							TC1,2, OL1,U1	TC1,2, OL1,U1					
				31-32	-							TC1,2, OL1,U1	TC1, OL1,U1					
				31-50	31-50							TC1,2, OL0,U1	TC1,2, OL0,U1					
	250	50/60	1	0.10-30	-	-	3000	-	-	5000		TC1,2, OL1,U1	TC1,2, OL1,U1					
				31-50	31-50							TC1, OL0,U1	TC1, OL0,U1					
				31-32	-							TC1, OL1,U1	TC1, OL1,U1					
				3	-		-	0.10-30	-	-		-	3000	1500	3000	TC1,2, OL0,U2	TC1, OL0,U2	Single Pole Breaker
																TC1, OL1, U2	TC1, OL1,U2	Two Pole Break
																TC1,2, OL1,U1	TC1,2, OL1,U1	
																TC1,2, OL1, U1	TC1,2, OL1,U1	
415	50/60	3	-	-	5000 ³	1000	3000	1500	3000	TC1,2, OL1, U1	TC1,2, OL1,U1							
80	DC	-								TC1,2, OL0,U1	TC1,2, OL0,U1							
Dual Coil	250	50/60	1	30-50	31-50	-	3000	-	-	5000	TC1,2, OL1,U1	TC1,2, OL1,U1						
				0.10-30	-						TC1,2, OL0,U1	TC1,2, OL0,U1						
				31-50	-						TC1,2, OL1,C1	TC1,2, OL1,C1						
				0.10-30	-						TC1,2, OL1,C1	TC1,2, OL1,C1						
				31-50	-						TC1,2, OL1,U1	TC1,2, OL1,U1						
Shunt	80	DC	-	0.10-30	-	-	7500	3000	1500	3000	TC1,2, OL1,U1	TC1,2, OL1,U1						
				30-50	31-50						TC1,2, OL1,U1	TC1,2, OL1,U1						
				0.10-30	-						TC1,2, OL0,U1	TC1,2, OL0,U1						
	250	50/60	1	30-50	31-50	-	3000	-	-	5000	TC1,2, OL1,U1	TC1,2, OL1,U1						
				0.10-30	-						TC1,2, OL1,C1	TC1,2, OL1,C1						
				31-50	-						TC1,2, OL1,C1	TC1,2, OL1,C1						
3	-	-	0.10-30	-	5000 ³	-	3000	1500	3000	TC1,2, OL1,U1	TC1,2, OL1,U1							
										31-50	-	TC1,2, OL1,C1	TC1,2, OL1,C1					
										2000 ²	-	TC1,2, OL1,C1	TC1,2, OL1,C1					

Notes:

- 1 General Purpose Ratings for UL/CSA Only.
- 2 Requires branch circuit backup with a UL LISTED Type K5 or RK5 fuse (15A minimum) at no more than 4 times the rating of the protector.
- 3 Same as note 1, except that backup fuse is limited to 80 A maximum.

Table C: Lists UL Recognized, CSA Certified configurations and performance capabilities as Protectors, Supplementary for Marine Electrical and Fuel Systems (CCN/Guide PEQZ2, File E75596). Ignition Protected per UL 1500. UL Classified Small Craft Electrical Devices, Marine in accordance with ISO 8846 (CCN/Guide UZMK, File MQ1515) as Marine Supplementary Protectors.

UL1500 (Marine Ignition Protection)							
Circuit Configuration	Voltage			Current Rating	Short Circuit Capacity (Amps)	Application Codes	
	Max Rating	Frequency	Phase	Full Load Amps	Without Backup Fuse	UL	CSA
Series	14 ¹	DC	-	0.02-50	5000	TC1,2, OL1,U1	TC1,2, OL1,U1
	32 ¹					TC1,2, OL0,U2	TC1,2, OL0,U2
	65				TC1,2, OL1,U1	TC1,2, OL1,U1	
	125/250	50/60	1 ²		1500	TC1,2, OL1,U1	TC1,2, OL1,U1
	250		1		1000	TC1,2, OL1,U1	TC1,2, OL1,U1

Notes:

- 1 Available with special catalog number only (consult factory).
- 2 pole protector required (with one pole per power line) for: 250/125 VAC, 125/250 VAC and 208V/120 VAC Power Systems. 1 pole protector required for : 125 VAC, 10 Power System.

Tech Specs

Tables

Table D: Lists UL Listed configurations and performance capabilities as Circuit Breakers for use in Communications Equipment (CCN/Guide DITT, File E189195), under UL489A

UL489A (Communication Equipment)				
Circuit Configuration	Voltage		Current Rating	Interrupting Capacity (Amps)
	Max Rating	Frequency	General Purpose Amps	Without Backup Fuse
Series	80	DC	0.10-50	5000
			60-90 ¹	

Notes:

¹ Parallel Pole Construction

Table E: Lists UL Listed (489) configuration and performance capabilities as a Molded Case Circuit Breaker.

UL489 Listed Branch Circuit Breakers						
Circuit Configuration	Voltage			Current Rating	Interrupting Capacity (Amps)	Construction Notes
	Max Rating	Frequency	Phase	Full Load Amps	Without Backup Fuse	
Series	120	50/60	1	0.10 - 30	5,000	1 pole
	120/240					2 pole
	120/240					2 or 3 poles (1 Pole of a 3 Pole Unit is for Neutral Break)
Dual Coil	120	50/60	1	0.10 - 30	5,000	1 pole
	120/240					2 pole
	120/240					2 or 3 poles (1 Pole of a 3 Pole Unit is for Neutral Break)

Time Delay Specs

To view all hydraulic-magnetic circuit breaker time delay values, please visit www.carlingtech.com/sites/default/files/documents/Carling-HM-CB-Time-Delays.pdf

Agency Approvals

UL 1077	Component Recognition Program as Protectors Supplementary (Guide CCN/QVNU2, File E75596)
UL 508	Switches, Industrial Control (Guide CCN/NRNT2, File E148683)
UL 1500	Protectors, Supplementary for Marine Electrical & Fuel Systems (Guide PEQZ2, File E75596) Ignition Protection
UL 489	Circuit Breakers, Molded Case, (Guide DIVQ, File E129899)
UL 489A	Communications Equipment (Guide CCN/DITT, File E189195)
CSA Accepted	Component Supplementary Protector under Class 3215 30, File 047848 0 000 CSA Standard C22.2 No. 235
TUV Certified	EN60934, under License No. R72103448
VDE Certified	EN60934, VDE 0642 under File No. 10537

Ordering Scheme

Handle - UL 1077 Recognized

Sample Part Number

B A 3 - B 0 - 10 - 450 - 1 B 1 - C

Selection 1 2 3 4 5 6 7 8 9 10 11

1. SERIES

B

2. ACTUATOR ¹

- A Handle, one per pole
- B Handle, one per multipole unit
- S Mid-Trip Handle, one per pole
- T Mid-Trip Handle, one per pole & Alarm Switch

3. POLES

- | | | |
|-------|---------|--------|
| 1 One | 3 Three | 5 Five |
| 2 Two | 4 Four | 6 Six |

4. CIRCUIT

- | | |
|--------------------------------------|--|
| A Switch Only (No Coil) ² | G Relay Trip (Voltage) ³ |
| B Series Trip (Current) | H Dual Coil with Shunt Trip ^{3,4} |
| C Series Trip (Voltage) | Voltage Coil |
| D Shunt Trip (Current) ³ | K Dual Coil with Relay Trip ^{3,4} |
| E Shunt Trip (Voltage) ³ | Voltage Coil |
| F Relay Trip (Current) ³ | |

5. AUXILIARY / ALARM SWITCH ⁵

- | | |
|--|--|
| 0 without Aux Switch | 7 S.P.S.T., 0.110 Q.C. Term. |
| 2 S.P.D.T., 0.110 Q.C. Term. (Gold Contacts) | 8 S.P.S.T., 0.187 Q.C. Term. (Gold Contacts) |
| 4 S.P.D.T., 0.110 Q.C. Term. | 9 S.P.D.T., 0.187 Q.C. Term. |

6. FREQUENCY & DELAY

- | | |
|---|---|
| 03 DC 50/60Hz, Switch Only ² | 30 DC, 50/60Hz Instantaneous |
| 10 DC Instantaneous ⁶ | 31 DC, 50/60Hz Ultra Short |
| 11 DC Ultra Short | 32 DC, 50/60Hz Short |
| 12 DC Short | 34 DC, 50/60Hz Medium |
| 14 DC Medium | 36 DC, 50/60Hz Long |
| 16 DC Long | 42 50/60Hz Short, High-inrush ⁷ |
| 20 50/60Hz Instantaneous | 44 50/60Hz Medium, High-inrush ⁷ |
| 21 50/60Hz Ultra Short | 46 50/60Hz Long, High-inrush ⁷ |
| 22 50/60Hz Short | 52 DC, Short, High-inrush ⁷ |
| 24 50/60Hz Medium | 54 DC, Medium, High-inrush ⁷ |
| 26 50/60Hz Long | 56 DC, Long, High-inrush ⁷ |

Notes:

- 1 Actuator Code: A: Handle tie pin spacer(s) and retainers provided unassembled with multi-pole units.
B: Handle location as viewed from front of breaker.
2 pole - left pole 3 pole - center pole
4 pole - two handles at center poles 5 pole - three handles at center poles
6 pole - four handles at center poles
- S: Handle moves to mid-position only upon electrical trip of the breaker. Available with circuit codes B, C, D, E, F, G, H and K.
- T: Handle moves to mid-position and alarm switch activates only upon electrical trip of the breaker. Available with circuit codes B & C.
- 2 Switch Only circuits, rated up to 50A and 6 poles, and only available with VDE Certification when tied to a protected pole (Circuit Code B, C, D or H.), For .02 to 30 A, select Current Code 630. For 35 - 50A, select Current Code 650.
- 3 Available with Terminal Codes 1, 2 & 3. Current Rating limited to 30A maximum.
- 4 Consult factory for available Dual Coil options, as special catalog number is required. With Shunt construction, Dual Coils will trip instantaneously on line voltage. Dual coils require 30VA minimum power to trip and are rated for intermittent duty only.
- 5 Auxiliary Switch breakers with Series Trip and Switch Only circuits. On multi-pole breakers, one auxiliary switch is supplied, mounted in the extreme right pole.
- 6 Separate pole type voltage coils not rated for continuous duty. Available only with delay codes 10 and 20.
- 7 Available with Circuit Codes B & D only. VDE Certified to 30A. UL Recognized and CSA Accepted to 50A.
- 8 VDE Certification available with single pole breakers with DC Delay only. UL Recognition and CSA Accepted available in one and two pole breakers.
- 9 Screw Terminals are recommended on ratings greater than 20 A. Ratings over 30 A are only available with Terminal Codes 5, 9, G, H, J, K, M and Q.
- 10 VDE Certification up to 25 A and UL Recognition and CSA Acceptance up to 30 A, but not recommended over 20A.
- 11 Terminal Codes 3, 5 E and H (Bus Type) with VDE, are supplied with Lock Washers, and Terminal Code M (M6 Threaded Stud) with VDE is supplied with Lock and Flat Washers. These breakers are only VDE Certified when the washers are used.
- 12 VDE available up to 12A. UL Rec. & CSA Acceptance available up to 30A.
- 13 1-Pole breakers with Terminal Code P (Printed Circuit Board) available up to 30A with VDE and 50A with UL Recognition & CSA Acceptance, Circuit Codes A, B & C. Two pole breakers with Terminal Code P (Printed Circuit Board) are available up to 40A with UL Recognition and CSA Acceptance with Circuit Codes A, B and C.
- 14 Available with Actuator Codes A, S and T.
- 15 Available with voltage coils only.
- 16 Terminal Code Q not available with VDE approvals.

7. CURRENT RATING (AMPERES)

CODE	AMPERES	CODE	AMPERES	CODE	AMPERES	CODE	AMPERES
020	0.020	225	0.250	420	2.000	611	11.000
025	0.025	230	0.300	522	2.250	711	11.500
030	0.030	235	0.350	527	2.750	612	12.000
035	0.035	240	0.400	430	3.000	712	12.500
040	0.040	245	0.450	435	3.500	613	13.000
045	0.045	250	0.500	440	4.000	614	14.000
050	0.050	255	0.550	445	4.500	615	15.000
055	0.055	260	0.600	450	5.000	616	16.000
060	0.060	265	0.650	455	5.500	617	17.000
065	0.065	270	0.700	460	6.000	618	18.000
070	0.070	275	0.750	465	6.500	620	20.000
075	0.075	280	0.800	470	7.000	622	22.000
080	0.080	285	0.850	475	7.500	624	24.000
085	0.085	290	0.900	480	8.000	625	25.000
090	0.090	295	0.950	485	8.500	630	30.000
095	0.095	410	1.000	490	9.000	635	35.000 ⁸
210	0.100	512	1.250	495	9.500	640	40.000 ⁸
215	0.150	415	1.500	610	10.000	645	45.000 ⁸
220	0.200	517	1.750	710	10.500	650	50.000 ⁸

OR VOLTAGE COIL (NORMAL RATED VOLTAGE) ⁶

A06	6 DC	A32	32 DC	J12	12 AC	J65	65 AC
A12	12 DC	A48	48 DC	J18	18 AC	K20	120 AC
A18	18 DC	A65	65 DC	J24	24 AC	L40	240 AC
A24	24 DC	J06	6 AC	J48	48 AC		

8. TERMINAL ⁹

- | | |
|---|---|
| 1 ¹⁰ Push-On 0.250 Tab (Q.C.) | C Screw, M4 with upturned lugs |
| 2 Screw 8-32 with upturned lugs | E ¹¹ Screw M4 (Bus Type) |
| 3 ¹¹ Screw 8-32 (Bus Type) | G Screw M5 (Bus Type) & 30° bend |
| 4 Screw 10-32 with upturned lugs | H Screw M5 (Bus Type) |
| 5 ¹¹ Screw 10-32 (Bus Type) | J Screw M5 Back Connect |
| 6 Screw 8-32 with upturned lugs & 30° bend | K Screw 10-32 Back Connect |
| 7 Screw 8-32 (Bus Type) | L ¹² 0.250 Q.C./ Solder Lug |
| 8 Screw 10-32 with upturned lugs & 30° bend | M ¹¹ M6 Threaded Stud |
| 9 Screw 10-32 (Bus Type) | N Screw M4 Back Connect |
| B Screw M5 with upturned lugs | P ¹³ Printed Circuit Board Terminals |
| | Q ¹⁶ Push-In Stud & 30° bend |
| | R Screw M4 with upturned lugs & 30° bend |
| | S ¹⁵ Push-On 0.110 Tab (Q.C.) |
| | T Screw M4 (Bus Type) & 30° bend |
| | Y Screw 8-32 Back Connect |

9. ACTUATOR COLOR & LEGEND

Actuator Color	I-O	ON-OFF	Dual	Legend Color
White	A	B	1	Black
Black	C	D	2	White
Red	F	G	3	White
Green	H	J	4	White
Blue	K	L	5	White
Yellow	M	N	6	Black
Gray	P	Q	7	Black
Orange	R	S	8	Black

10. MOUNTING / BARRIERS

	MOUNTING STYLE	BARRIERS
1	Threaded Insert, 2 per pole	
A	6-32 x 0.195 inches	no
2	6-32 x 0.195 inches (multi-pole units only)	yes
A	ISO M3 x 5mm	no
B	ISO M3 x 5mm	yes
	Rectangular Adapter Plate with mounting centers of 2.062 inches [52.37mm] and Threaded insert, 2 per pole	
3 ¹⁴	6-32 x 0.225 inches	no
C ¹⁴	6-32 x 0.225 inches (multi-pole units only)	yes
4 ¹⁴	ISO M3 x 6.5mm	no
D ¹⁴	ISO M3 x 6.5mm	yes
	Front panel Snap-In, 0.75" [19.05mm] wide bezel	
5	without Handleguard	no
6	without Handleguard (multi-pole only)	yes
	Front panel Snap-In, 0.96" wide bezel	
7	without Handleguard, 1-pole 0.96" wide;	no
8	without Handleguard, 1-pole 0.96" wide; multipole units have .105" bezel overhang on all sides	yes
	(multipole only) .105" bezel overhang on all sides	

11 AGENCY APPROVAL

- C UL Recognized & CSA Accepted
- D VDE Certified, UL Recognized & CSA Accepted
- E TUV Certified, UL Recognized & CSA Accepted
- I UL Recognized STD 1077, UL Recognized 1500 (ignition protected), & CSA Accepted

Configure Complete Part Number >

Browse Standard Parts >

Ordering Scheme

Handle - UL 489A Listed

Sample Part Number

B A 1 - B 0 - 14 - 450 - 1 B 1 - M T

Selection 1 2 3 4 5 6 7 8 9 10 11 12

1. SERIES

B

2. ACTUATOR ¹

A	Handle, one per pole
B	Handle, one per multi-pole unit
S	Mid-Trip Handle, one per pole
T	Mid-Trip Handle, one per pole & Alarm Switch A Handle, one per pole
B	Handle, one per multi-pole unit
S	Mid-Trip Handle, one per pole
T	Mid-Trip Handle, one per pole & Alarm Switch

3. POLES ²

1	One	3	Three
2	Two	4	Four

4. CIRCUIT

B Series Trip (Current)

5 AUXILIARY/ALARM SWITCH ²

0	without Aux Switch	8	S.P.S.T., 0.187 Q.C. Term.
2	S.P.D.T., 0.110 Q.C. Term.	9	S.P.S.T., 0.187 Q.C. Term.
3	S.P.D.T., 0.110 Solder lug.		
7	S.P.S.T., 0.110 Q.C. Term. (Gold Contacts)		

6 FREQUENCY & DELAY ⁴

11	DC Ultra Short	52	DC, Short, High-inrush
12	DC Short	54	DC, Medium, High-inrush
14	DC Medium	56	DC, Long, High-inrush
16	DC Long		

7. CURRENT RATING (AMPERES)

CODE	AMPERES							
210	0.100	285	0.850	455	5.500	613	13.000	
215	0.150	290	0.900	460	6.000	614	14.000	
220	0.200	295	0.950	465	6.500	615	15.000	
225	0.250	410	1.000	470	7.000	616	16.000	
230	0.300	512	1.250	475	7.500	617	17.000	
235	0.350	415	1.500	480	8.000	618	18.000	
240	0.400	517	1.750	485	8.500	620	20.000	
245	0.450	420	2.000	490	9.000	622	22.000	
250	0.500	522	2.250	495	9.500	624	24.000	
255	0.550	527	2.750	610	10.000	625	25.000	
260	0.600	430	3.000	710	10.500	630	30.000	
265	0.650	435	3.500	611	11.000	635 ³	35.000	
270	0.700	440	4.000	711	11.500	640 ³	40.000	
275	0.750	445	4.500	612	12.000	645 ³	45.000	
280	0.800	450	5.000	712	12.500	650 ³	50.000	

8. TERMINAL ⁴

1 ⁵	Push-On 0.250 Tab (Q.C.)	B	Screw M5 with upturned lugs
2	Screw 8-32 with upturned lugs	F	Screw M5 with upturned lugs & 30° bend
3 ⁶	Screw 8-32 (Bus Type)	G	Screw M5 (Bus Type) & 30° bend
4	Screw 10-32 with upturned lugs	H	Screw M5 (Bus Type)
5 ⁶	Screw 10-32 (Bus Type)	J	Screw M5 Back Connect
6	Screw 8-32 with upturned lugs & 30° bend	K	Screw 10-32 Back Connect
7	Screw 8-32 (Bus Type) & 30° bend	M ⁶	M6 Threaded Stud
8	Screw 10-32 with upturned lugs & 30° bend	N	Screw M4 Back Connect
9	Screw 10-32 (Bus Type) & 30° bend	P ⁷	Printed Circuit Board Terminals
		Q ⁸	Push-In Stud & 30° bend
		Y	Screw 8-32 Back Connect

9 ACTUATOR COLOR & LEGEND

Actuator Color	ON-OFF	Dual	Legend Color
White	B	1	Black
Black	D	2	White
Red	G	3	White
Green	J	4	White
Blue	L	5	White
Yellow	N	6	Black
Gray	Q	7	Black
Orange	S	8	Black

10. MOUNTING / BARRIERS

	MOUNTING STYLE	BARRIERS
	Threaded Insert, 2 per pole	
1	6-32 x 0.195 inches	no
A	6-32 x 0.195 inches (multi-pole units only)	yes
2	ISO M3 x 5mm	no
B	ISO M3 x 5mm	yes
	Rectangular Adapter Plate with mounting centers of 2.062 inches [52.37mm] and Threaded insert, 2 per pole	
3	6-32 x 0.225 inches	no
C	6-32 X 0.225 inches (multi-pole units only)	yes
4	ISO M3 x 6.5mm	no
D	ISO M3 x 6.5mm	yes
	Front panel Snap-In, 0.75" [19.05mm] wide bezel	
5	without Handleguard	no
6	without Handleguard (multi-pole only)	yes
	Front panel Snap-In, 0.96" wide bezel	
7	without Handleguard	no
8	without Handleguard (multi-pole only)	yes
	.105" bezel overhang on all sides, for multi-pole units.	

11. MAXIMUM APPLICATION RATING

M 80 DC

12. AGENCY APPROVAL

T	UL489A Listed
K	UL489A Listed, VDE Certified
J	UL489A Listed, TUV Certified

Notes:

- Actuator Code:
A: Handle tie pin spacer(s) and retainers provided unassembled with multi-pole units.
S: Handle moves to mid-position only upon electrical trip of the breaker.
T: Handle moves to mid-position and alarm switch activates only upon electrical trip of the breaker.
- On multi-pole breakers, one auxiliary switch is supplied, mounted in the extreme right pole.
- VDE Certification available with single pole breakers only. UL489A Listing available with one and two pole breakers.
- Screw Terminals are recommended on ratings greater than 20 amps. Ratings over 30 amps are only available with Terminal Codes 5, 9, G, H, J, K, M and Q.
- Terminal Code I (Push-On) available up to 25 amps with TUV or VDE Certification and 30 amps with UL489A Listing, but is not recommended over 20 amps.
- Terminal Codes 3, 5 and H (Bus Type) with TUV or VDE, are supplied with Lock Washers, and Terminal Code M (M6 Threaded Stud) with TUV or VDE is supplied with Lock and Flat Washers. These breakers are only TUV or VDE Certified when the washers are used.
- Single pole breakers with Terminal Code P (Printed Circuit Board) are available up to 30 amps with VDE Certification and 50 amps with UL489A Listing.
- Terminal Code Q not available with VDE approvals.

[Configure Complete Part Number >](#)

[Browse Standard Parts >](#)

Ordering Scheme Handle - UL 489 Listed

Sample Part Number **B A 1 - B 0 - 24 - 450 - 1 B A - K G**

Selection 1 2 3 4 5 6 7 8 9 10 11 12

1. SERIES

B

2. ACTUATOR ¹

A Handle, one per pole
 B Handle, one per multi-pole unit
 S Mid-Trip Handle, one per pole
 T Mid-Trip Handle, one per pole & Alarm Switch

3. POLES ²

1 One 2 Two 3 Three ³

4. CIRCUIT

B Series Trip (Current)

5 AUXILIARY/ALARM SWITCH ⁴

0 without Aux Switch
 2 S.P.D.T., 0.110 Q.C. Term.
 3 S.P.D.T., 0.110 Solder Lug
 8 S.P.S.T., 0.187 Q.C. Term.
 9 S.P.D.T., 0.187 Q.C. Term.

6 FREQUENCY & DELAY

21 AC Ultra Short	42 AC, Short, High-inrush
22 AC Short	44 AC, Medium, High-inrush
24 AC Medium	46 AC, Long, High-inrush
26 AC Long	

7. CURRENT RATING (AMPERES)

CODE	AMPERES							
210	0.100	285	0.850	455	5.500	613	13.000	
215	0.150	290	0.900	460	6.000	614	14.000	
220	0.200	295	0.950	465	6.500	615	15.000	
225	0.250	410	1.000	470	7.000	616	16.000	
230	0.300	512	1.250	475	7.500	617	17.000	
235	0.350	415	1.500	480	8.000	618	18.000	
240	0.400	517	1.750	485	8.500	620	20.000	
245	0.450	420	2.000	490	9.000	622	22.000	
250	0.500	522	2.250	495	9.500	624	24.000	
255	0.550	527	2.750	610	10.000	625	25.000	
260	0.600	430	3.000	710	10.500	630	30.000	
265	0.650	435	3.500	611	11.000			
270	0.700	440	4.000	711	11.500			
275	0.750	445	4.500	612	12.000			
280	0.800	450	5.000	712	12.500			

8. TERMINAL ⁴

1 Push-On 0.250 Tab (Q.C.)	A Load Terminal #8 Screw (Q.C.)
2 Screw 8-32 with upturned lugs	B Combination (Special Catalog #)
3 Screw 8-32 (Bus Type)	F Screw M5 with upturned lugs
4 Screw 10-32 with upturned lugs	G Screw M5 (Bus Type) & 30° bend
5 Screw 10-32 (Bus Type)	H Screw M5 (Bus Type)
6 Screw 8-32 with upturned lugs & 30° bend	J Screw M5 Back Connect
7 Screw 8-32 (Bus Type) & 30° bend	K Screw 10-32 Back Connect
8 Screw 10-32 with upturned lugs & 30° bend	M M6 Threaded Stud
9 Screw 10-32 (Bus Type) & 30° bend	N Screw M4 Back Connect
	Q Push-In Stud
	Y Screw 8-32 Back Connect

9 ACTUATOR COLOR & LEGEND

Actuator Color	ON-OFF	Dual	Legend Color
White	B	1	Black
Black	D	2	White
Red	G	3	White
Green	J	4	White
Blue	L	5	White
Yellow	N	6	Black
Gray	Q	7	Black
Orange	S	8	Black

10. MOUNTING / BARRIERS ⁹

	MOUNTING STYLE	BARRIERS
	Threaded Insert, 2 per pole	
A	6-32 x 0.195 inches	yes
B	ISO M3 x 5mm	yes
	Rectangular Adapter Plate with mounting centers of 2.062 inches [52.37mm] and Threaded insert, 2 per pole	
C	6-32 x 0.225 inches	yes
D	ISO M3 x 6.5mm	yes
	Front panel Snap-In, 0.75" [19.05mm] wide bezel	
6	without Handguard	yes
	Front panel Snap-In, 0.96" wide bezel	
8	without Handguard	yes
	.105" bezel overhang on all sides, for multi-pole units	

11. MAXIMUM APPLICATION RATING

C ⁸ 120/240VAC
 K 120VAC

12. AGENCY APPROVAL

G UL489 Listed
 3 UL489 Listed, TUV Certified

Notes:

- Actuator Code:
 A: Handle tie pin spacer(s) and retainers provided un-assembled with multi-pole units.
 B: Handle location as viewed from front of breaker:
 2 pole - left pole 3 pole - center pole
 S: Handle moves to mid-position only upon electrical trip of the breaker. Available with circuit codes B, C, D, E, F, G, H and K.
 T: Handle moves to mid-position and alarm switch activates only upon electrical trip of the breaker. Available with circuit codes B & C.
 All poles must be same polarity.
- All poles must be same polarity.
- 3 pole units available only when 1 of 3 poles is neutral.
- Auxiliary/Alarm Switch circuit must be same polarity as the main circuit. On multi-pole breakers, one auxiliary switch is supplied, mounted in the extreme right pole.
- Screw Terminals are recommended on ratings greater than 20 amps.
- Standard actuator colors are black and white.
- Adapter plate with mounting centers of 2.082 inches. Available with Actuator Codes A, S and T.
- Voltage Rating available with 2 and 3-pole breakers only.
- Barriers supplied on multi-pole units only.

[Configure Complete Part Number >](#)

[Browse Standard Parts >](#)

Circuit & Terminal Diagrams Handle

inches [millimeters]

	CIRCUIT SCHEMATIC		CIRCUIT CODE	AUX SWITCH CODE	CIRCUIT SCHEMATIC		CIRCUIT CODE	AUX SWITCH CODE
	ANSI	IEC			ANSI	IEC		
	SWITCH ONLY (NO COIL)				SERIES TRIP			
SERIES TRIP (2 TERM'S.) 			A	O			B C	O
SERIES TRIP W/ AUX SWITCH (5 TERM'S.) 	SWITCH ONLY (NO COIL) WITH AUXILIARY SWITCH 		A	2 4 4	SERIES TRIP WITH AUXILIARY / ALARM SWITCH 		B C	2 4 4
SHUNT TRIP (3 TERM'S.) 	SHUNT TRIP 		D E	0	DUAL COIL; SERIES TRIP CURRENT COIL, SHUNT TRIP VOLTAGE COIL 		H	0
RELAY TRIP (4 TERM'S.) 	RELAY TRIP 		F G	0	DUAL COIL; SERIES TRIP CURRENT COIL, RELAY TRIP VOLTAGE COIL 		K	0

HANDLE POSITION VS. AUX/ALARM SWITCH MODE						
CIRCUIT BREAKER MODE	STANDARD C/B		MID TRIP C/B		MID TRIP C/B	
	HANDLE POSITION	AUX. SWITCH MODE	HANDLE POSITION	ALARM SWITCH MODE	HANDLE POSITION	AUX. SWITCH MODE (w/ALARM SWITCH)
OFF						
ON						
ELECTRICAL TRIP						

Notes:
 1 Tolerance ± 0.020 [.51] unless otherwise specified.
 2 Alarm Switch available with .110 x .020 Q.C. & Solder Lug Terminals Only.

Circuit & Terminal Diagrams Handle

inches [millimeters]

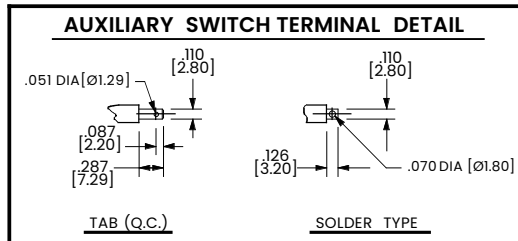
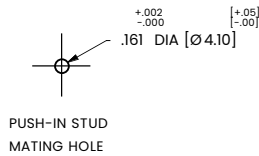
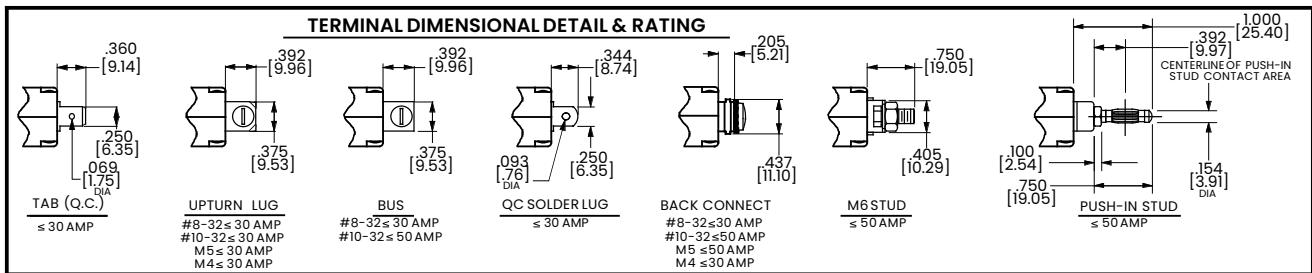

**TABLE A
TIGHTENING TORQUE
SPECIFICATIONS**

THREAD SIZE	TORQUE
#6-32 & M3 MOUNTING HARDWARE	7-9 IN-LBS [0.8-1.0 NM]
#8-32 & M4 THREAD TERMINAL SCREW	12-15 IN-LBS [1.4-1.7 NM]
#10-32 & M5 THREAD TERMINAL SCREW	15-20 IN-LBS [1.7-2.3 NM]

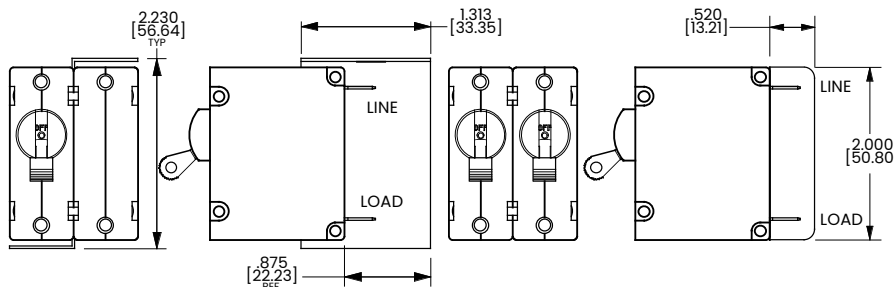
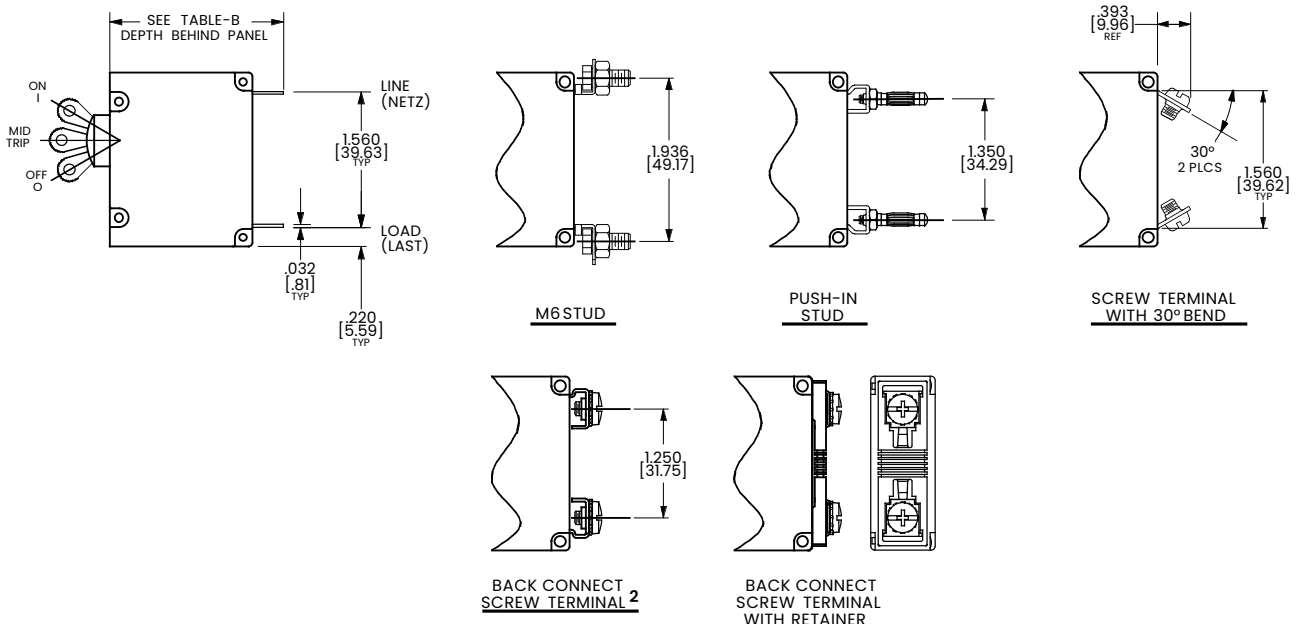

TABLE B

TERMINAL DESCRIPTION		DEPTH BEHIND PANEL
MAIN	TAB (Q.C.)	2.090 [53.09]
	SCREW TYPE	2.122 [53.90]
SHUNT, RELAY & DUAL COIL	TAB (Q.C.)	2.612 [66.35]
	SCREW #8-32 W/UPTURNED LUGS	2.644 [67.16]
AUX. SWITCH*	TAB (Q.C.) .110 x .020	2.537 [64.44]
	SOLDER TYPE	2.348 [59.64]

* AVAILABLE ON SERIES TRIP AND SWITCH ONLY CIRCUITS. WHEN CALLED FOR ON MULTI-POLE UNITS, ONLY ONE AUX. SWITCH IS NORMALLY SUPPLIED, AS SHOWN IN MULTI-POLE IDENTIFICATION SCHEME.



- Notes:
- 1 Tolerance ±.020 [.51] unless otherwise specified.
 - 2 Special Catalog part number required for back connect screw terminal without retainer

Dimensional Specs Handle

inches [millimeters]

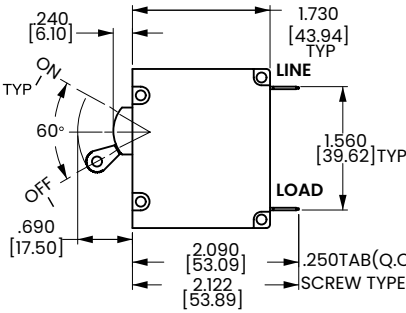
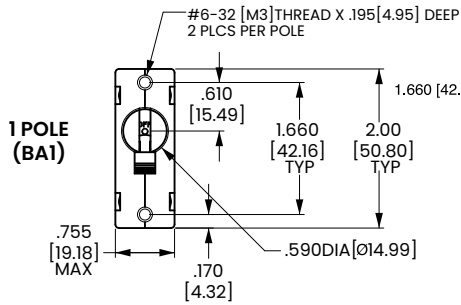

TAB (Q.C.) TYPE TERMINALS IN SERIES TRIP CIRCUIT CONFIGURATION SHOWN. FOR OTHER CONFIGURATIONS, SEE CIRCUIT AND TERMINAL DIAGRAMS.

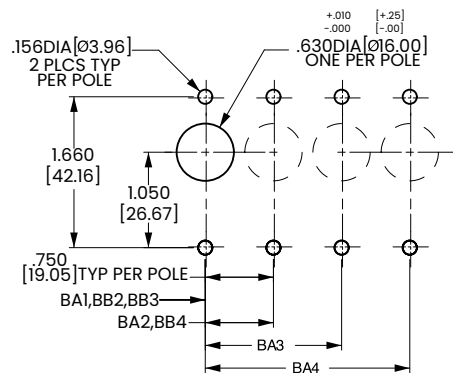
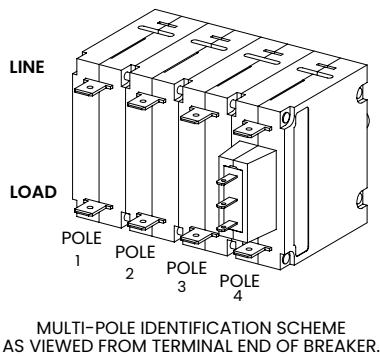
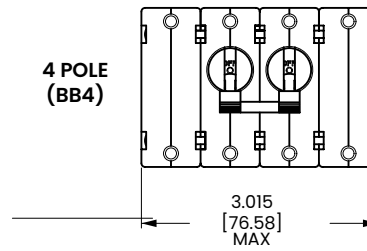
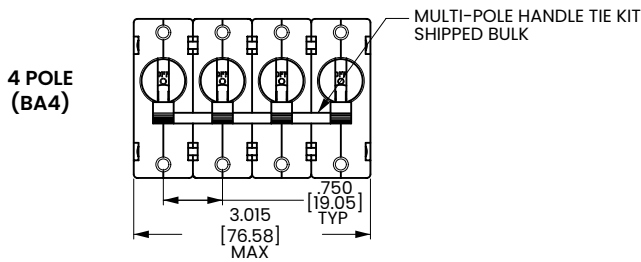
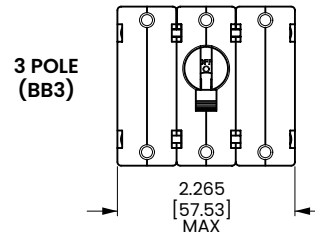
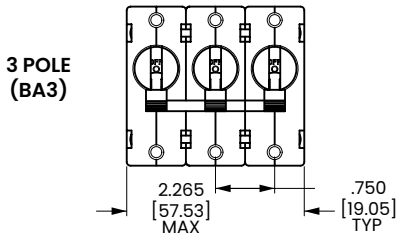
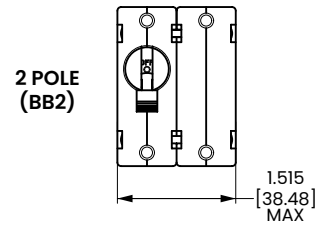
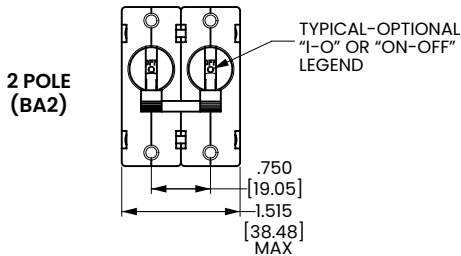

PANEL CUTOUT DETAIL
TOLERANCES ±.005 [±.12]

Notes:
1 Tolerance ± 0.20 [.51] unless otherwise specified.

Dimensional Specs Handle

inches [millimeters]

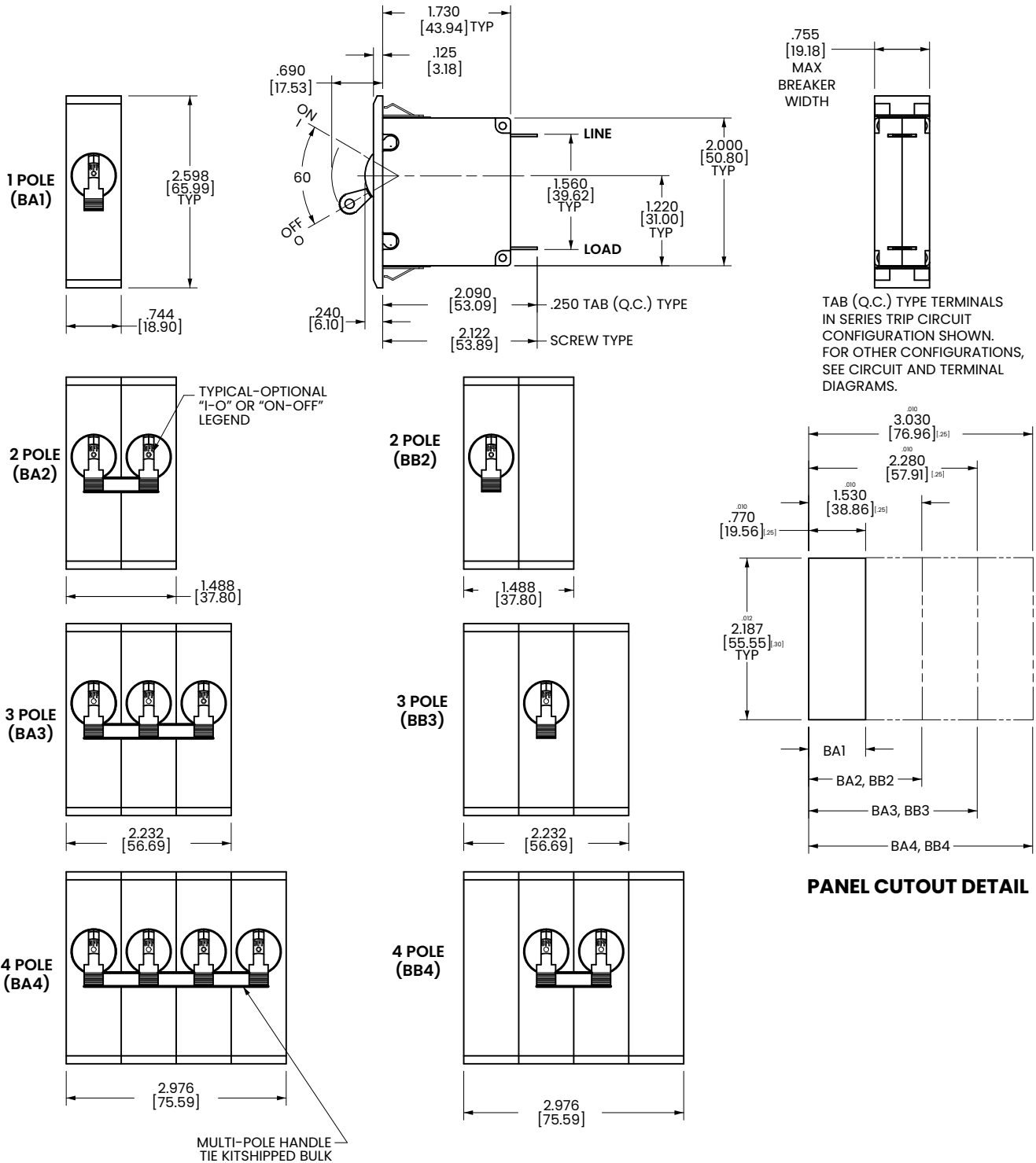

Notes:
 1 Recommended panel thickness: .040 [1.02] to .100 [2.54].
 2 Tolerance ±.020 [.51] unless otherwise specified.

Dimensional Specs Handle

inches [millimeters]

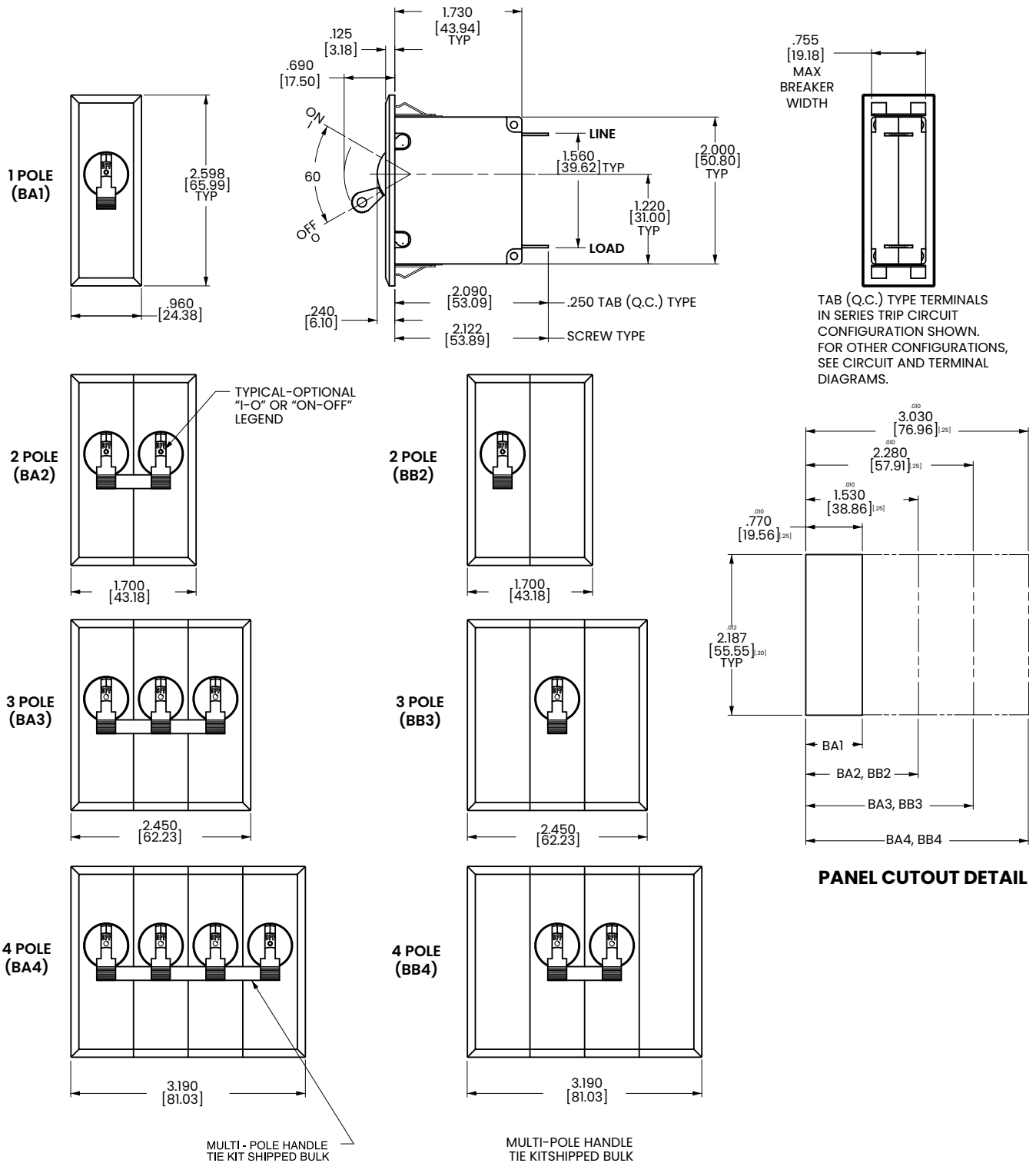

Notes:
 1 Recommended panel thickness: .040 [1.02] to .100 [2.54].
 2 Tolerance ±.020 [.51] unless otherwise specified.

Ordering Scheme Rocker - UL 489 Listed

Sample Part Number

B F 1 - B 0 - 24 - 630 - 2 3 A - K G

Selection 1 2 3 4 5 6 7 8 9 10 11 12

1. SERIES

B

2. ACTUATOR ¹

Two Color Visi-Rocker

- C** Indicate ON, vertical legend
- D** Indicate ON, horizontal legend
- F** Indicate OFF, vertical legend
- G** Indicate OFF, horizontal legend

Single color

- J** Vertical legend
- K** Horizontal legend

ROCKER STYLE DESCRIPTIONS

	INDICATE "ON"	INDICATE "OFF"	SINGLE COLOR
VERTICAL STYLE	CODE "C" 	CODE "F" 	CODE "J"
	CODE "D" 	CODE "G" 	CODE "K"

3. POLES ^{1,2}

- 1 One 2 Two 3 Three ³

4. CIRCUIT

B Series Trip (Current)

5 AUXILIARY/ALARM SWITCH ⁴

- | | |
|-------------------------------------|---|
| 0 without Aux Switch | 7 S.P.S.T., 0.110 Q.C. Term. (Gold Contacts) |
| 1 S.P.D.T., 0.093 Q.C. Term. | 8 S.P.S.T., 0.187 Q.C. Term. |
| 2 S.P.D.T., 0.110 Q.C. Term. | 9 S.P.D.T., 0.187 Q.C. Term. |
| 3 S.P.D.T., 0.110 Solder Lug | |

6. FREQUENCY & DELAY

- | | |
|--------------------------|-----------------------------------|
| 21 AC Ultra Short | 42 AC, Short, High-inrush |
| 22 AC Short | 44 AC, Medium, High-inrush |
| 24 AC Medium | 46 AC, Long, High-inrush |
| 26 AC Long | |

7. CURRENT RATING (AMPERES)

CODE	AMPERES						
210	0.100	285	0.850	455	5.500	613	13.000
215	0.150	290	0.900	460	6.000	614	14.000
220	0.200	295	0.950	465	6.500	615	15.000
225	0.250	410	1.000	470	7.000	616	16.000
230	0.300	512	1.250	475	7.500	617	17.000
235	0.350	415	1.500	480	8.000	618	18.000
240	0.400	517	1.750	485	8.500	620	20.000
245	0.450	420	2.000	490	9.000	622	22.000
250	0.500	522	2.250	495	9.500	624	24.000
255	0.550	527	2.750	610	10.000	625	25.000
260	0.600	430	3.000	710	10.500	630	30.000
265	0.650	435	3.500	611	11.000		
270	0.700	440	4.000	711	11.500		
275	0.750	445	4.500	612	12.000		
280	0.800	450	5.000	712	12.500		

8. TERMINAL ⁵

- | | |
|--|---|
| 1 ⁶ Push-On 0.250 Tab (Q.C.) | 9 Screw 10-32 (Bus Type) & 30° bend |
| 2 Screw 8-32 with upturned lugs | B Screw M5 with upturned lugs |
| 3 Screw 8-32 (Bus Type) | C Screw M4 with upturned lugs |
| 4 Screw 10-32 with upturned lugs | F Screw M5 with upturned lugs & 30° bend |
| 5 Screw 10-32 (Bus Type) | G Screw M5 (Bus Type) & 30° bend |
| 6 Screw 8-32 with upturned lugs & 30° bend | H Screw M5 (Bus Type) |
| 7 Screw 8-32 (Bus Type) & 30° bend | J Screw M5 Back Connect |
| 8 Screw 10-32 with upturned lugs & 30° bend | K Screw 10-32 Back Connect |
| | N Screw M4 Back Connect |
| | Y Screw 8-32 Back Connect |

9 ACTUATOR COLOR & LEGEND

Actuator or Visi-Color ⁷	Marking:	Marking Color
White B	ON-OFF	Dual ⁷ White
Black D	2 White	n/a
Red G	3 White	Red
Green J	4 White	Green
Blue L	5 White	Blue
Yellow N	6 Black	Yellow
Gray Q	7 Black	Gray
Orange S	8 Black	Orange

10. MOUNTING / BARRIERS

	MOUNTING STYLE	BARRIERS ⁹
A	Threaded Insert, 2 per pole	
B	6-32 x 0.195 inches (multipole units only)	yes
	ISO M3 x 5mm	yes
C	ROCKERGUARD BEZEL	
	Threaded Insert, 2 per pole	
D	6-32 X 0.225 inches (multipole units only)	yes
	ISO M3 x 6.5mm	yes

11. MAXIMUM APPLICATION RATING

- C** ⁸ 120/240VAC
K 120VAC

12. AGENCY APPROVAL

- G** UL489 Listed
3 UL489 Listed, TUV Certified

Notes:

- 1 Multi-pole breakers have all breakers identical except when specifying Auxiliary switch and/or mixed poles, and have one rocker per breaker.
- 2 All poles must be same polarity.
- 3 3 pole units available only when 1 of 3 poles is neutral.
- 4 On multi-pole breakers, one auxiliary switch is supplied, mounted in the extreme right pole.
- 5 Screw Terminals are recommended on ratings greater than 20 amps.
- 6 Terminal Code 1 (Push-On) available up to 30 amps, but are not recommended over 20 amps.
- 7 Dual legend = ON-OFF/I-O
- 8 Voltage Rating available with 2 and 3-pole breakers only.
- 9 Barriers supplied on multi-pole units only.

[Configure Complete Part Number >](#)

[Browse Standard Parts >](#)

Dimensional Specs

Rocker - UL 489 Listed

inches [millimeters]

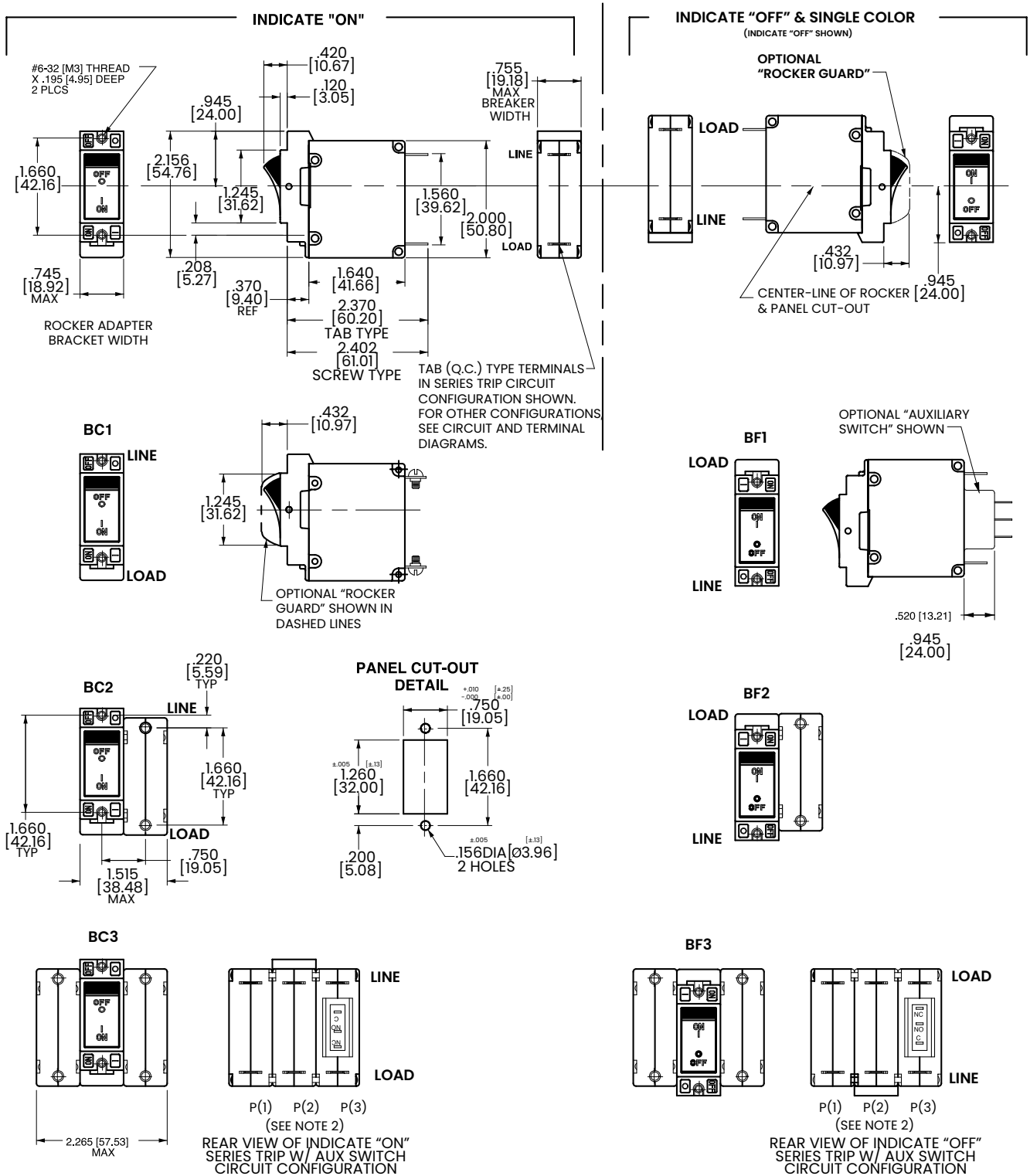

Notes:

- 1 Dimensions apply to all variations shown. Notice that circuit breaker line & load terminal orientation on indicate "OFF" is opposite of indicate "ON".
- 2 For pole orientation with horizontal legend, rotate front view clockwise 90°.
- 3 Tolerance ±.020 [51] unless otherwise specified.

Ordering Scheme Flat Rocker - UL 489 Listed

Sample Part Number

B 1 1 - B 0 - 24 - 630 - 2 3 A - K G

Selection 1 2 3 4 5 6 7 8 9 10 11 12

1. SERIES

B

2. ACTUATOR 1

Two Color Visi-Rocker
1 Indicate OFF, vertical legend
2 Indicate OFF, horizontal legend
Single color
3 Vertical legend
4 Horizontal legend

Push-To-Reset, Visi-Rocker
5 Indicate OFF, vertical legend
6 Indicate OFF, horizontal legend
Push-To-Reset, Single color
7 Vertical legend
8 Horizontal legend

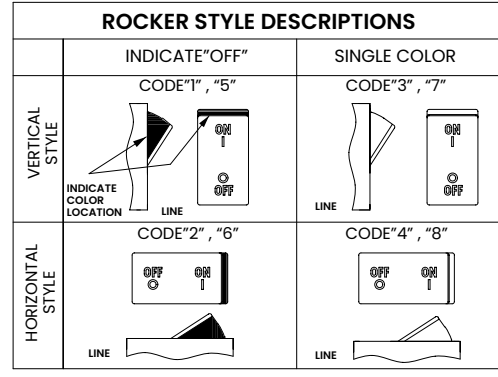

3. POLES 1,2

1 One **2** Two **3** Three ⁴

4. CIRCUIT

B Series Trip (Current)

5 AUXILIARY/ALARM SWITCH 4

0 without Aux Switch	7 S.P.D.T., 0.110 Q.C. Term. (Gold Contacts)
1 S.P.D.T., 0.093 Q.C. Term.	8 S.P.D.T., 0.187 Q.C. Term.
2 S.P.D.T., 0.110 Q.C. Term.	9 S.P.D.T., 0.187 Q.C. Term.
3 S.P.D.T., 0.110 Solder Lug	

6. FREQUENCY & DELAY

21 AC Ultra Short	42 AC, Short, High-inrush
22 AC Short	44 AC, Medium, High-inrush
24 AC Medium	46 AC, Long, High-inrush
26 AC Long	

7. CURRENT RATING (AMPERES)

CODE	AMPERES	
210	0.100	285 0.850
215	0.150	290 0.900
220	0.200	295 0.950
225	0.250	410 1.000
230	0.300	512 1.250
235	0.350	415 1.500
240	0.400	517 1.750
245	0.450	420 2.000
250	0.500	522 2.250
255	0.550	527 2.750
260	0.600	430 3.000
265	0.650	435 3.500
270	0.700	440 4.000
275	0.750	445 4.500
280	0.800	450 5.000
		455 5.500
		460 6.000
		465 6.500
		470 7.000
		475 7.500
		480 8.000
		485 8.500
		490 9.000
		495 9.500
		610 10.000
		710 10.500
		611 11.000
		711 11.500
		612 12.000
		712 12.500
		613 13.000
		614 14.000
		615 15.000
		616 16.000
		617 17.000
		618 18.000
		620 20.000
		622 22.000
		624 24.000
		625 25.000
		630 30.000

8. TERMINAL 6

1 Push-On 0.250 Tab (Q.C.)	9 Screw 10-32 (Bus Type) & 30° bend
2 Screw 8-32 with upturned lugs	B Screw M5 with upturned lugs
3 Screw 8-32 (Bus Type)	C Screw, M4 with upturned lugs
4 Screw 10-32 with upturned lugs	F Screw M5 with upturned lugs & 30° bend
5 Screw 10-32 (Bus Type)	G Screw M5 (Bus Type) & 30° bend
6 Screw 8-32 with upturned lugs & 30° bend	H Screw M5 (Bus Type)
7 Screw 8-32 (Bus Type) & 30° bend	J Screw M5 Back Connect
8 Screw 10-32 with upturned lugs & 30° bend	K Screw 10-32 Back Connect
	N Screw M4 Back Connect
	Y Screw 8-32 Back Connect

9 ACTUATOR COLOR & LEGEND

Actuator or Visi-Color ⁸	Marking:		Marking Color	
	ON-OFF	Dual ⁷	Single Color	Visi-Rocker
White	B	1	Black	White
Black	D	2	White	n/a
Red	G	3	White	Red
Green	J	4	White	Green
Blue	L	5	White	Blue
Yellow	N	6	Black	Yellow
Gray	Q	7	Black	Gray
Orange	S	8	Black	Orange

10. MOUNTING / BARRIERS

	STANDARD ROCKER BEZEL Threaded Insert, 2 per pole	BARRIERS ¹²
A	6-32 x 0.195 inches (multi-pole units only)	yes
B	ISO M3 x 5mm	yes
	RECESSED OFF SIDE ROCKER ACTUATOR ¹⁰	
E	6-32 X 0.225 inches (multi-pole units only)	yes
F	ISO M3 x 6.5mm	yes
	PUSH-TO-RESET BEZEL, Threaded Insert, 2 per pole	
C	6-32 x 0.195 inches	yes
D	ISO M3 x 5mm	yes

11. MAXIMUM APPLICATION RATING

C 120/240VAC ¹¹
K 120VAC

12. AGENCY APPROVAL

G UL489 Listed
3 UL489 Listed, TUV Certified

Notes:

- Push-To-Reset actuators have OFF portion of rocker shrouded.
- Multi-pole breakers have all breakers identical except when specifying Auxiliary switch and/or mixed poles, and have one rocker per breaker.
- All poles must be same polarity.
- 3 pole units available only when 1 of 3 poles is neutral.
- On multi-pole breakers, one auxiliary switch is supplied, mounted in the extreme right pole.
- Screw Terminals are recommended on ratings greater than 20 amps.
- Terminal Code 1 (Push-On) available up to 30 amps, but are not recommended over 20 amps.
- Color shown is visi and legend with remainder of rocker black, Dual = ON-OFF/I-O legend.
- Legend on Push-to-reset bezel/shroud is white with single color actuator codes 7 & 8. Legend on Push-To-Reset bezel/shroud matches Visi-Color of rocker with actuator codes 5 & 6.
- Recessed "off-side" available with actuator codes 1, 2, 3 & 4. Legends on rocker are available in ink stamping only.
- Voltage rating available with 2 & 3-pole breakers only.
- Barriers supplied on multi-pole units only.

[Configure Complete Part Number >](#)

[Browse Standard Parts >](#)

Dimensional Specs

Flat Rocker UL489 Listed

inches [millimeters]

INDICATE "OFF" & SINGLE COLOR
(INDICATE "OFF" SHOWN)

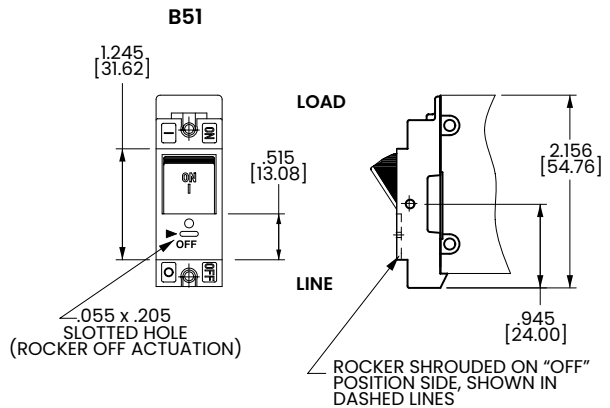
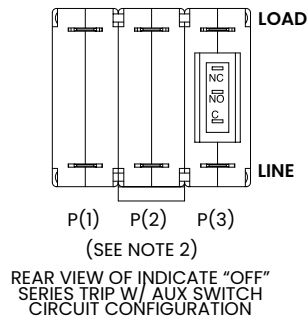
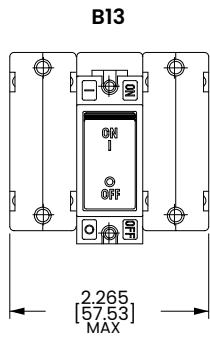
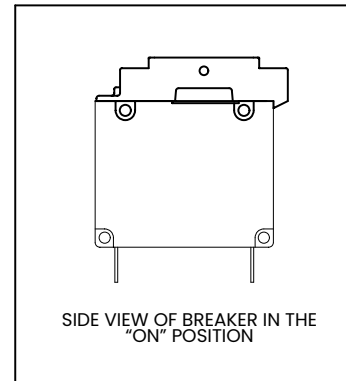
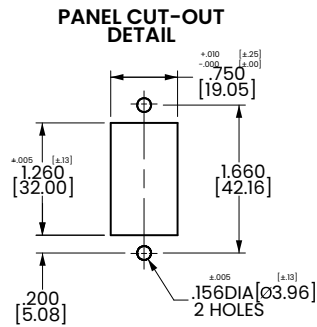
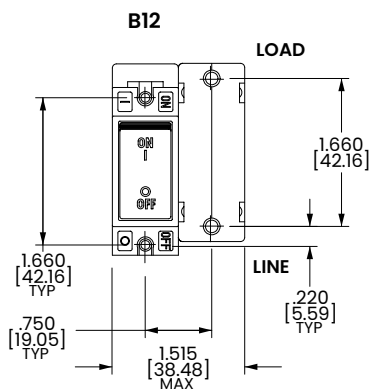
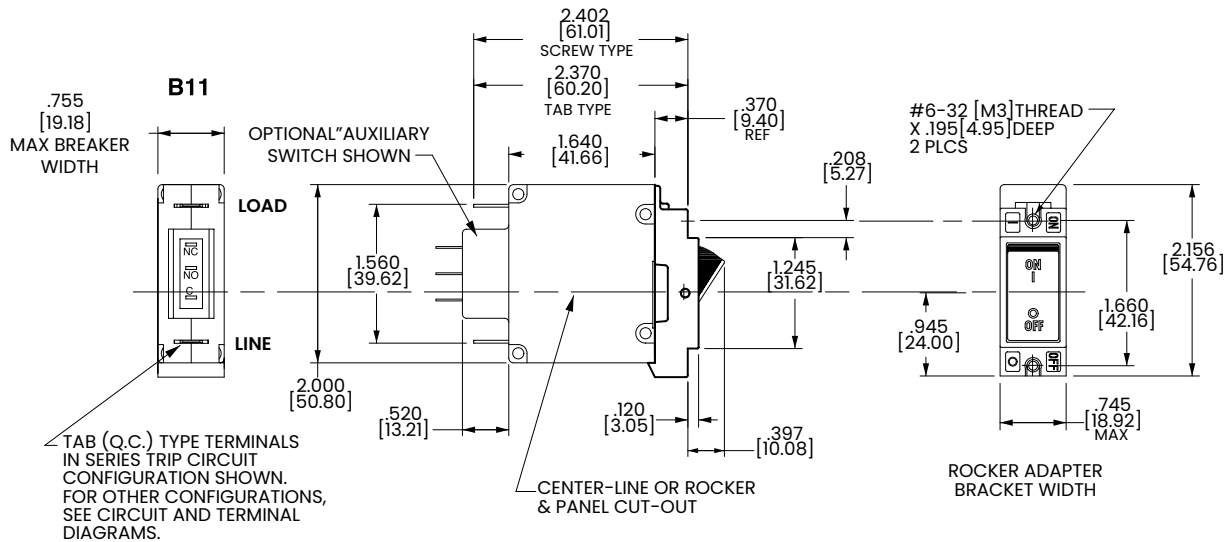

ACTUATOR SIDE VIEW
(SURFACE CONTOURS)

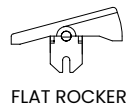

- Notes:
1 For pole orientation with horizontal legend, rotate front view clockwise 90°.
2 Tolerance ±.010 [0.25] unless otherwise specified.

PC Terminal Diagrams

inches [millimeters]

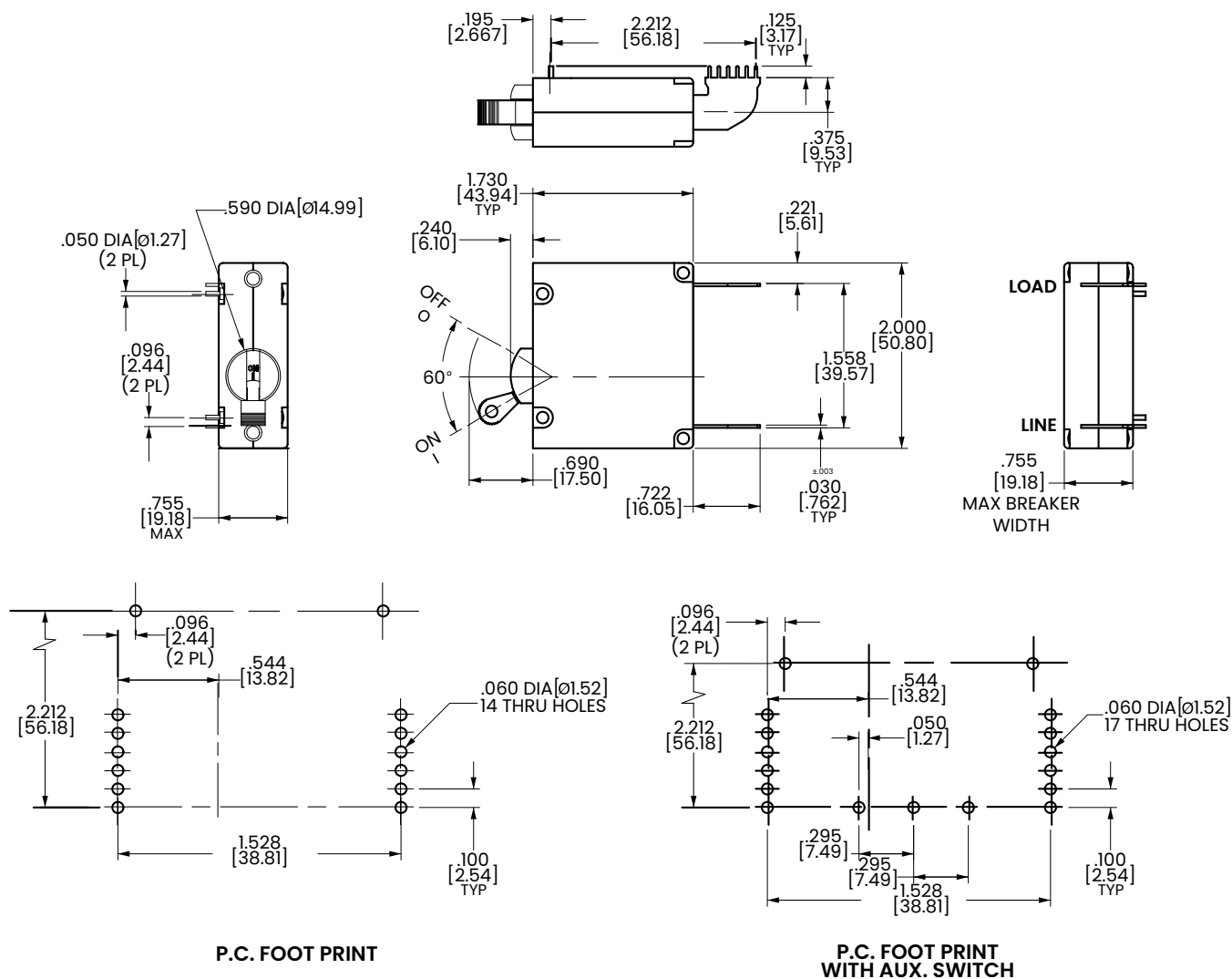

Notes:

- 1 For pole orientation with horizontal legend, rotate front view clockwise 90°.
- 2 Tolerance ±.010 [.25] unless otherwise specified.

TB-Series

Hydraulic-Magnetic Circuit Breaker

[PRODUCT WEBPAGE](#)

request sample, configure part, watch video

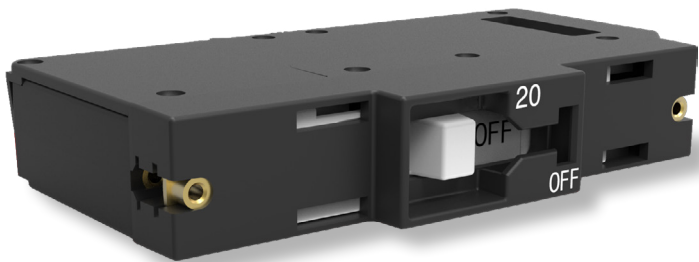

Tandem Circuit Breaker

Developed as a two pole breaker designed to fit into a single rack unit, the TB-Series hydraulic-magnetic circuit breaker delivers versatile functionality for tight spaces. An integrated trip-free mechanism inhibits manual overrides during overcurrent or fault conditions for added safety. This tandem pole breaker is rated up to 20 amps, 120/240VAC, with a max IC of 10,000 amps for UL and 5,000 amps for TUV.

2 Poles

Fits in 1RU

0.10-20

Amps

120/240

VAC

Typical Applications

- Datacom
- Power Distribution Units

Tech Specs

Electrical

Maximum Voltage	120/240VAC 50/60 Hz
Current Ratings	Standard current coils: 0.200, 0.350, 0.500, 0.750, 1.00, 2.50, 5.00, 7.50, 10.0, 15.0, 20.0 Amps. See ordering scheme for additional ratings
Auxiliary/Alarm Switch	10.1A 250VAC
Rating(s)	0.1A 80VDC
Dielectric Strength	Meets UL and CSA Requirements and can withstand 1500 VAC, 60Hz for one minute between all electrically isolated terminals. Breakers to hold 100%, and must trip at 125% of rated current and greater within the time limit shown on Table B. Data shown represents breaker response at ambient temperature of 77° F (25° C) with no preloading. Breakers are mounted vertically in standard wall-mount position.
Insulation Resistance	Minimum of 100 Megohms @ 500VDC
Overload	50 operations @ 600% rated current
Inrush Pulse Tolerance	Standard delays 12x rated current, high inrush delays 25x for 1/2 cycle @ 60 Hz
Resistance, Impedance	(Across circuit breaker terminals)

RESISTANCE, IMPEDANCE VALUES
from Line to Load Terminals
(Values Based on Series Trip Circuit Breaker)

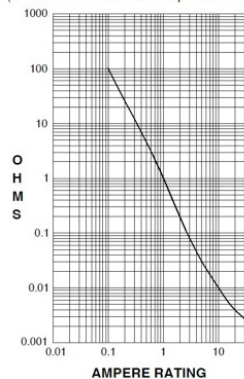

CURRENT (AMPS)	TOLERANCE (%)
0.10 - 5.0	± 15
5.1 - 20.0	± 25

Agency Approvals

UL 489 (Listed)	as Molded Case Circuit Breakers
TUV Certified	IEC/EN 60947-2
cULus Certified	CAN/CSA 22.2 No. 5

Time Delay Specs

To view all hydraulic-magnetic circuit breaker time delay values, please visit www.carlingtech.com/sites/default/files/documents/Carling-HM-CB-Time-Delays.pdf

Tables Table A: Voltage and Current Rating

UL489 Listed, cULus and TUV Certified Circuit Breakers						
Circuit Configuration	Voltage			Current Rating	Interrupting Capacity (Amps)	
	Max Rating	Frequency	Phase	Full Load Amps	UL / cULus	TUV
Series	120/240	50 / 60	1	0.10 - 20	10,000	5,000
	240 ¹	50 / 60	1	0.10 - 20	---	5,000

Notes:
1 Voltage rating requires wiring configuration according to TUV, see Dimensional Specifications drawings for wiring diagram.

Mechanical

Endurance	6,000 ON-OFF operations @ 6 per minute; with rated Current and Voltage. 4,000 ON-OFF operations with no load.
Trip Free	All TB-Series Circuit Breakers will trip on overload, even when Handle is forcibly held in the ON position.
Trip Indication	The operating Actuator moves positively to the OFF position when an overload causes the breaker to trip.

Physical

Internal Circuit Config.	Series, with or without auxiliary / alarm switch
Weight	Approximately 170g/5.75oz per unit
Standard Color	Housing - Black Actuator - White or Black with contrasting ON-OFF legends
Mounting	Refer to the dimensional specs page

Environmental

Designed and tested in accordance with requirements of specification MIL-PRF-55629 & MIL-STD-202 as follows:

Shock	-Withstands 100G's, 6ms sawtooth while carrying rated current per Method 213B, Test Condition "I". Instantaneous and ultra short curves tested @ 90% rated current.
Vibration	-40° C to +85° C
Moisture Resistance/ Humidity	Method 106G, i.e. ten 24-hour Humidity cycles @ +25° C to +65° C, 80-98% RH
Salt Spray	Method 101E, Condition A (90-95% RH @ 5% NaCl Solution, 96 hours)
Thermal Shock	Method 107G, Condition A (Five cycles @ -55° C to +25° C to +85° C to 25° C)
Operating Temperature	-20° C to +85° C
Storage Temperature	-40° C to +85° C

Ordering Scheme

Sample Part Number

T B 2 - B 0 - 24-620 - J 2 1 - C 3

Selection 1 2 3 4 5 6 7 8 9 10 11 12

1. TYPE

T Tandem Breaker

2. SERIES

B B-Series Circuit Breaker

3. POLES

2 Two

4. CIRCUIT

B Series Trip (Current)

5. AUXILIARY SWITCH ³

0 without Aux Switch
1 S.P.D.T., 0.093 Q.C. Term.
2 S.P.D.T., 0.110 Q.C. Term.
3 S.P.D.T., 0.110 Solder Lug
8 S.P.S.T., 0.187 Q.C. Term.
9 S.P.D.T., 0.187 Q.C. Term.

6. FREQUENCY & TIME DELAY

21 50/60Hz Ultra Short
22 50/60Hz Short
24 50/60Hz Medium
26 50/60Hz Long
42 50/60Hz Short, High-inrush
44 50/60Hz Medium, High-inrush
46 50/60Hz Long, High-inrush

7. CURRENT RATING (AMPERES)

CODE	AMPERES				
210	0.10	280	0.80	440	4.00
215	0.15	285	0.85	445	4.50
220	0.20	290	0.90	450	5.00
225	0.25	295	0.95	455	5.50
230	0.30	410	1.00	460	6.00
235	0.35	512	1.25	465	6.50
240	0.40	415	1.50	470	7.00
245	0.45	517	1.75	475	7.50
250	0.50	420	2.00	480	8.00
255	0.55	522	2.25	485	8.50
260	0.60	425	2.50	490	9.00
265	0.65	527	2.75	495	9.50
270	0.70	430	3.00	610	10.00
275	0.75	435	3.50	710	10.50

8. TERMINAL ¹

J Screw M5 Back Connect
K Screw 10-32 Back Connect
N Screw M4 Back Connect
Y Screw 8-32 Back Connect

9. ACTUATOR COLOR & LEGEND

Actuator Color	I-O	ON-OFF	Dual	Legend Color
White	A	B	1	Black
Black	C	D	2	White
Red	F	G	3	White
Green	H	J	4	White
Blue	K	L	5	White
Yellow	M	N	6	Black
Gray	P	Q	7	Black
Orange	R	S	8	Black

10. MOUNTING

	HORIZONTAL MOUNTING STYLE	BARRIER
1	6-32 x .195 in. Threaded Inserts	Offset
3	6-32 x .195 in. Threaded Inserts	Standard
A	6-32 x .195 in. Threaded Inserts with Actuator Guard	Offset
C	6-32 x .195 in. Threaded Inserts with Actuator Guard	Standard
2	ISO M3 x 5 mm Threaded Inserts	Offset
4	ISO M3 x 5 mm Threaded Inserts	Standard
B	ISO M3 x 5 mm Threaded Inserts with Actuator Guard	Offset
D	ISO M3 x 5 mm Threaded Inserts with Actuator Guard	Standard
	VERTICAL MOUNTING STYLE	BARRIER
5	6-32 x .195 in. Threaded Inserts	Offset
7	6-32 x .195 in. Threaded Inserts	Standard
E	6-32 x .195 in. Threaded Inserts with Actuator Guard	Offset
G	6-32 x .195 in. Threaded Inserts with Actuator Guard	Standard
6	ISO M3 x 5 mm Threaded Inserts	Offset
8	ISO M3 x 5 mm Threaded Inserts	Standard
F	ISO M3 x 5 mm Threaded Inserts with Actuator Guard	Offset
H	ISO M3 x 5 mm Threaded Inserts with Actuator Guard	Standard

11. APPLICATION RATING

C 120/240 VAC

12. AGENCY APPROVAL

A Without Approvals
G UL 489 Listed
3 4 UL 489 Listed, TUV Certified

Notes:

- 1 Pole with auxiliary switch is supplied with 30 degree bus terminals.
- 2 Only available with terminal codes J, K, N, Y.
- 3 Supplied with one auxiliary switch. See dimensional specs drawings for location.
- 4 TUV certification only available with I/O ON/OFF markings (Actuator code: 1, 2, 3, 4, 5, 6, 7, 8)

[Configure Complete Part Number >](#)

[Browse Standard Parts >](#)

Dimensional Specs

inches [millimeters]

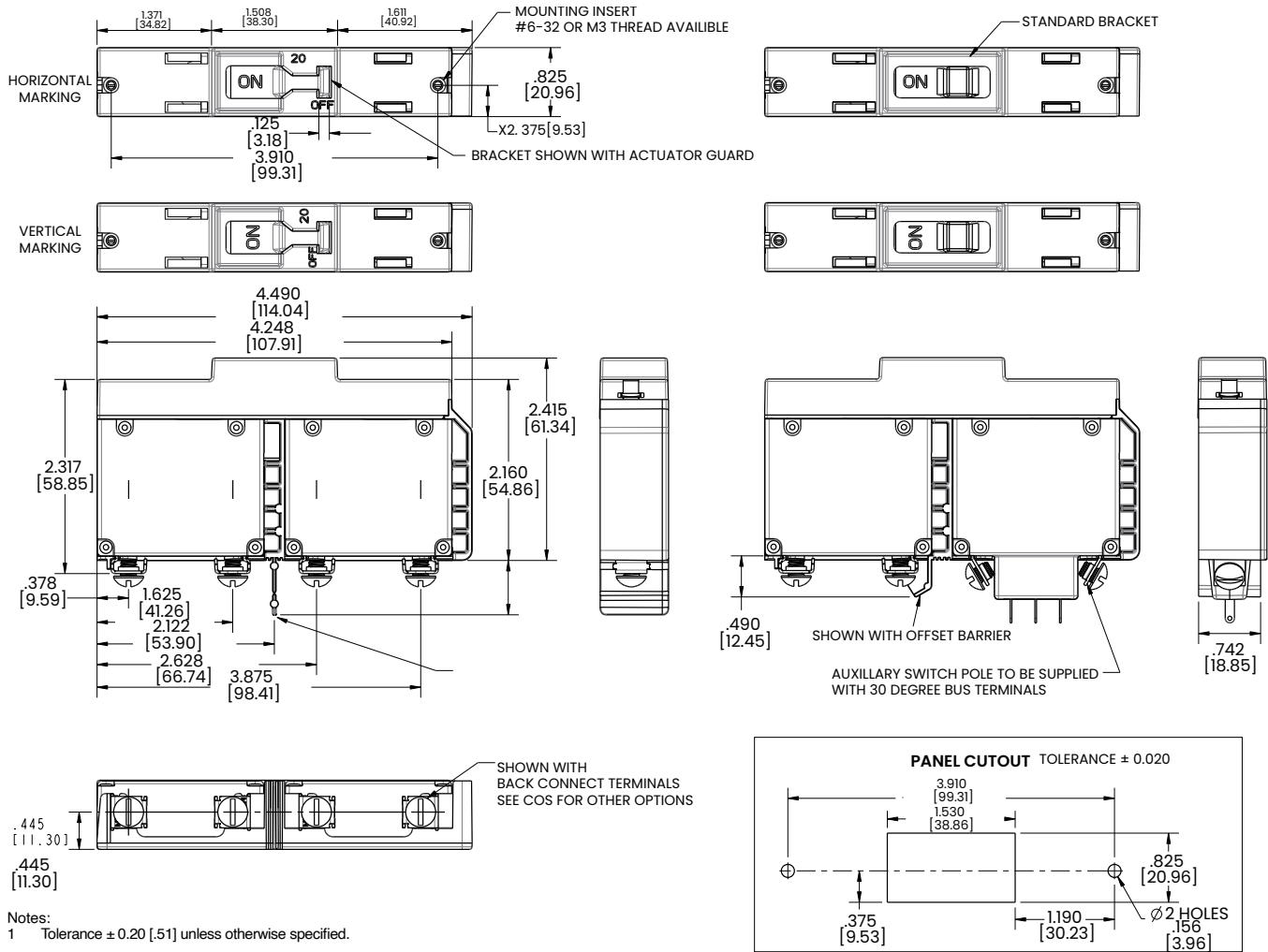

Wiring Diagrams:

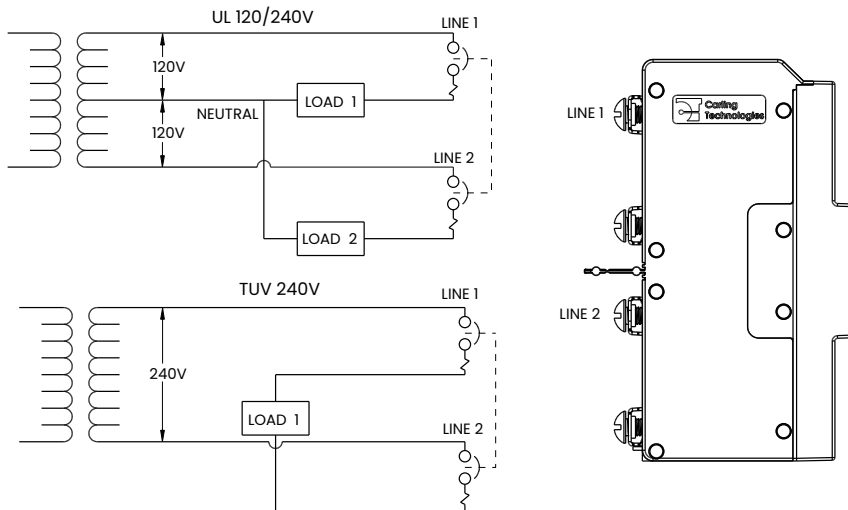

C-Series

Hydraulic-Magnetic Circuit Breaker

PRODUCT WEBPAGE

request sample, configure part

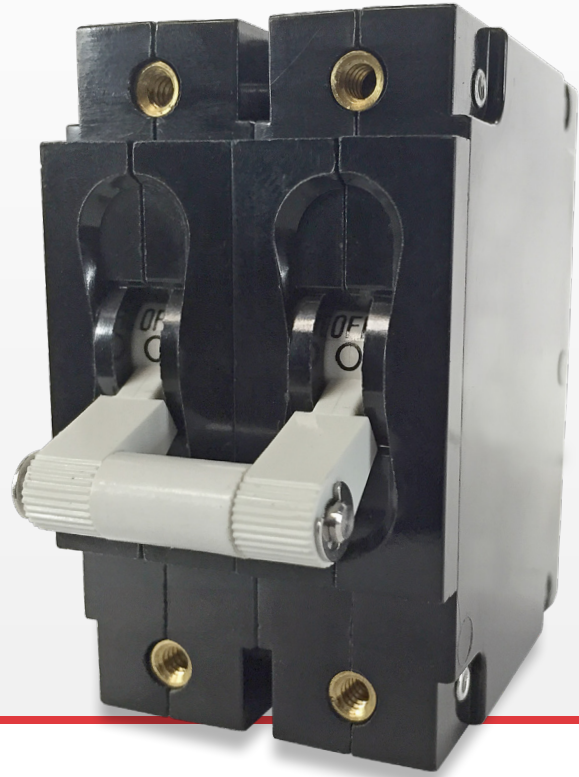

Compact Circuit Breaker with High Amperage and Voltage Capabilities

Compact yet robust, the C-Series hydraulic-magnetic circuit breaker is designed for high amperage and voltage applications. C-Series breakers are available as a one to six pole configuration and are rated up to 100 amps, 480VAC/80VDC or 240VAC/125VDC for UL 489 configurations. Parallel pole options offer ratings from 100–250 amps. The C-Series employs a unique arc chute design which allows for higher interrupting capacities of up to 10,000 amps.

1-6	250	480	125
Poles	Amps Max	VAC Max	VDC Max

Typical Applications

- Marine
- Renewable Energy
- Military
- Commercial Food
- Datacom/Telecom
- Generators & Welders
- Industrial Automation
- Medical Equipment

Tech Spec

Electrical

Maximum Voltage	AC, 480 WYE/277 VAC, 50/60 Hz (see Table A.) UL489: AC,240 VAC. (See Table D),50/60 Hz, 125 VDC
Current Ratings	Standard current coils: 0.100, 0.250, 0.500, 0.750, 1.00, 2.50, 5.00, 7.50, 10.0, 15.0, 25.0, 30.0, 35.0, 40.0, 50.0, 60.0, 70.0, 80.0, 90.0 and 100 amps. Other ratings available, see ordering scheme.
Standard Voltage Coils	DC - 6V, 12V; AC - 120V; other ratings available, see ordering scheme.
Auxiliary Switch Rating	SPDT; 10.1 amps-250VAC, DC Aux.Switch 1.0A, 65 VDC. 0.5A, 80VDC,1/4 HP, 125VAC,VDE & TUV1.0 125 VAC.
Insulation Resistance	Minimum of 100 Megohms at 500 VDC.
Dielectric Strength	UL, CSA: 1960 V 50/60 Hz for oneminute between all electrically isolated terminals. C-Series Circuit Breakers comply with the 8mm spacing and 3750V 50/60 Hz dielectric requirements from hazardous voltage to operator accessible surfaces, between adjacent poles and from main circuits to auxiliary circuits per Publications EN 60950 and VDE 0805.
Resistance, Impedance	Values from Line to Load Terminal -based on Series Trip Circuit Breaker.

RESISTANCE, IMPEDANCE VALUES from Line to Load Terminals (Values Based on Series Trip Circuit Breaker)

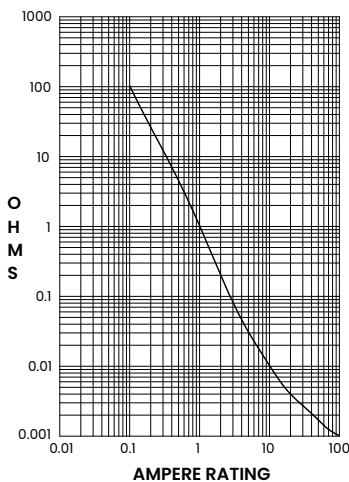

CURRENT (AMPS)	TOLERANCE (%)
0.10 - 5.0	15
5.1 - 20.0	25
20.1 - 50.0	35

Pulse Tolerance Curves

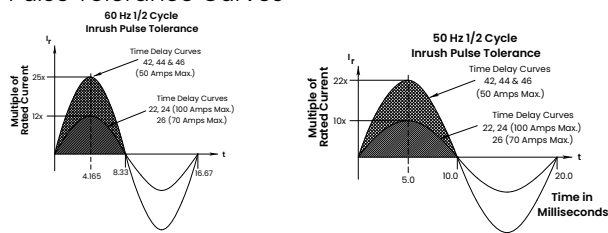

Mechanical

Endurance	10,000 ON-OFF operations @ 6 per minute; with rated current & voltage.
Trip Free	All circuit breakers will trip on overload, even when actuator is forcibly held in the ON position.
Trip Indication	The operating actuator moves positively to the OFF position when an overload causes the breaker to trip. With mid-trip, handle moves to the mid position on electrical trip of the circuit breaker. With mid trip handle with alarm switch, handle moves to the mid position and the alarm switch actuates when the circuit breaker is electrically tripped.
Number of Poles	1-6 poles ≤ 50A; 1-4 poles @ 51-70A; 1-2 poles 71-100A. UL489 Handle: 1 pole ≤ 100A, 2 pole ≤50A; Rocker: 1 pole ≤ 100A
Internal Circuit Config.	Series (with or without auxiliary switch, mid trip & mid trip with alarm switch) Shunt & Relay with current or voltage trip coils, Dual Coil, Switch Only (with or without aux. switch). UL489: Series (with or without auxiliary switch, mid-trip & midtrip with alarm switch).
Weight	Approx.112 grams/pole (3.95 oz).
Standard Colors	Housing: Black

Environmental

Designed and tested in accordance with requirements of specification MIL-PRF-55629 & MIL-STD-202 as follows:

Shock	Withstands 100Gs,6mssawtooth while carrying rated current perMethod 213, Test Condition "I". Instantaneous and ultrashort curves tested @ 90% of rated current.
Vibration	Withstands 0.060" excursion from 10-55 Hz & 10 Gs 55-500 Hz, @ rated current per Method 204C, Test Cond. A. Instantaneous & ultrashort curves tested @ 90% of rated current.
Moisture Resistance	Method 106D, i.e., ten 24-hour cycles @ +25°C to +65°C, 80-98% RH..
Salt Spray	Method 101, Condition A (90-95% RH @ 5% NaCl Solution, 96 hrs).
Thermal Shock	RH @ 5% NaCl Solution, 96 hrs). Thermal Shock Method 107D, Condition A (five cycles @ -55°C to +25°C to +85°C to +25°C).
Operating Temperature	-40° C to +85° C

Tech Specs

Tables

Table A: Lists UL Recognized & CSA Accepted configurations and performance capabilities as a component supplementary protector

Component Supplementary Protectors																		
Circuit Configuration	Voltage			Current Rating		Short Circuit Capacity (Amps)		Application Codes		Construction Notes								
	Max. Rating	Frequency	Phase	Full Load Amps	General Purpose Amps	UL / CSA		UL	CSA									
						With Backup Fuse	Without Backup Fuse											
Series	32	DC	---	0.02 - 100	---	---	5,000	TC1, OL1, U2	TC1, OL1, U2	---								
	48			110 - 150				TC1, 2, OL1, U1	TC1, 2, OL1, U1									
	65			0.02 - 70				71 - 100	TC1, 2, OL0, U1		TC1, 2, OL0, U1							
				-				---	TC1, 2, OL1, U1		TC1, 2, OL1, U1							
	80			0.02 - 70				---	7,500		TC1, 2, OL1, U1	TC1, 2, OL1, U1						
				---				71 - 100	10,000		TC1, 2, OL1, U1	TC1, 2, OL1, U1						
				0.02 - 70				---	5,000		TC1, 2, OL0, U1	TC1, 2, OL0, U1						
	125			50 / 60				1	0.02 - 50		---	---	---	TC1, 2, OL1, U1	TC1, 2, OL1, U1	Must have Agency "L"		
	125/250													TC1, 2, OL1, U1	TC1, 2, OL1, U1	Must have Agency "L"		
	250													TC1, 2, OL1, U1	TC1, 2, OL1, U1	Must have Agency "L". 250 volts requires 2 pole		
														---	---	---		
	125													5,000	3,000	TC1, OL1, U2	TC1, OL1, U2	Per pole rating
	150	DC	---		---	80 - 100 101 - 175	---			---				5,000	TC1, 2, OL1, U1	TC1, 2, OL1, U1	Must have Agency "L"	
														---	---	---	Must have Agency "L"	
	125/250	50 / 60	1		0.02 - 100	---	---			---				3,500	TC1, OL1, U2	TC1, OL1, U2	---	
														3,000	TC1, 2, OL1, U1	TC1, 2, OL1, U1	2 or 3 poles breaking single phase	
														1,000	TC1, 2, OL1, U1	TC1, 2, OL1, U1	2 or 3 poles breaking single phase	
														5,000	TC1, 2, OL1, U2	TC1, 2, OL1, U2	2 or 3 poles breaking single phase. Agency "L"	
														3,500	TC1, 2, OL1, U2	TC1, 2, OL1, U2	Per pole rating	
				5,000				TC1, 2, OL1, U1	TC1, 2, OL1, U1		Must have Agency "L"							
				250				3	---		0.02 - 100	---	---	5,000	---	TC1, 2, OL1, C1	TC1, 2, OL1, C1	---
															3,000	TC1, 2, OL0, U2	TC1, 2, OL0, U2	---
															5,000	---	---	3 poles breaking 3 phase
				480/277				1	---		0.02 - 50	---	---	5,000	---	0.02 - 90	---	Must have Agency "L"
---															---	---	---	
480				3				1	0.02 - 30		---	---	5,000	---	---	---	3 poles breaking 3 phase	
	---	---	---		---													
Dual Coil	50 / 60	1	0.02 - 50	---	---	---	7,500	TC1, 2, OL1, U1	TC1, 2, OL1, U1	---								
							3,000	TC1, OL1, U2	TC1, OL1, U2	Per pole rating								
							3,500	TC1, OL1, U2	TC1, OL1, U2	2 or 3 poles breaking single phase								
							3,000	TC1, 2, OL1, U1	TC1, 2, OL1, U1	2 or 3 poles breaking single phase								
							3,500	TC1, OL1, U2	TC1, OL1, U2	---								
							3,000	TC1, OL0, U2	TC1, OL0, U2	Per pole rating								
							277	3	1	0.02 - 50	---	---	5,000	---	---	---	3 poles breaking 3 phase	
														---	---	---	---	
							480/277	3	1	0.02 - 30	---	---	5,000	---	---	---	---	
														---	---	---	---	
							480	1	---	0.02 - 30	---	---	5,000	---	---	---	2 poles breaking 1 phase	
														---	---	---	---	
Shunt	50 / 60	3	0.02 - 30	---	---	5,000	---	---	---	---								
							---	---	---	---								
							---	---	---	---								
							---	---	---	---								
							---	---	---	---								
							---	---	---	---								
							---	---	---	---								
							---	---	---	---								
							---	---	---	---								
							---	---	---	---								
							---	---	---	---								
							---	---	---	---								
Relay	50 / 60	1	0.02 - 50	---	---	5,000	---	7,500	TC1, 2, OL1, U1	TC1, 2, OL1, U1	---							
							---	---	---	---								
							---	---	---	---								
Switch Only	50 / 60	1	0.02 - 100	---	---	---	---	---	---	2 or 3 poles breaking single phase								
											65	71 - 100	---	---				
											80	---	---	---				
											125	---	---	---				
											125/250	---	---	---				
											250	---	---	---				
											277	---	---	---				
480/277	---	---	---	---														
480	3	1	0.02 - 30	---	---	5,000	---	---	---	3 poles breaking 3 phase								
							---	---	---	---								

Notes:

- Requires branch circuit backup with a UL LISTED Type K5 or RK5 fuse rated 15A minimum and no more than 4 times full load amps not to exceed 125A for 50 Amp or less rating and not to exceed 175 for 51 through 100 Amp rating

Tech Specs

Tables

Table B: Lists UL Recognized and CSA Accepted configurations and performance capabilities as a Manual Motor Controller.

Manual Motor Controllers					
Circuit Configuration	Voltage			Current Rating	Horsepower Ratings
	Max. Rating	Frequency	Phase	Full Load Amps	Max. HP
Series, Shunt & Relay Switch Only	120 ¹	50 / 60	1	0.02 - 50	7 1/2
	250 ¹			0.02 - 20	3
	277 ¹				5
	480 ²				3

Notes:

- Requires branch circuit backup with a UL Listed Type K5 or RK5 fuse rated 15A Minimum and no more than 4 times full load amps not to exceed 125A for 50 Amp or less rating and not to exceed 175A for 51 through 100A rating. UL Recognized and CSA Certified at 480V refers to 3 and 4 pole versions used in a 3Ø, WYE connected circuit or a 2 pole version with 2 poles breaking 1Ø and backed up with a series fusing as stated in note 1.
- Shunt and Relay Trip - Voltage Coil Construction not current coils

Table C: Lists UL Recognized, CSA Accepted, VDE and TUV Certified configurations and performance capabilities as a Component Supplementary Protector.

Component Supplementary Protectors														
Circuit Configuration	Voltage			Current Rating		Short Circuit Capacity (Amps)						Application Codes	Construction Notes	
	Max. Rating	Frequency	Phase	Full Load Amps	General Purpose Amps ¹	UL / CSA		VDE		TUV		UL / CSA		
						With Backup Fuse	Without Backup Fuse	(Inc) With Backup Fuse	(Inc) Without Backup Fuse	(Inc) With Backup Fuse	(Inc) Without Backup Fuse			
Series	80	DC	---	0.10 - 70	---	---	7,500	---	5,000	5,000	1,500	TC1,2,OL1,U1	---	
				71 - 100	71 - 100								10,000	---
	125			50 / 60	1	1 - 50	---	5,000	3,000	1,500	3,000	1,500	TC1,2,OL1,U1	Agency J or R
	0.10 - 50					0.10 - 70								0.10 - 100
	250	50 / 60	3	0.10 - 30	---	5,000 ²	---	5,000	2,500	3,000	---	TC1,2,OL1,C1	---	
				0.10 - 100									3,000	1,500
	415	50 / 60	3	0.10 - 30	---	5,000 ²	---	5,000	2,500	3,000	---	TC1,2,OL1,C1	Rocker	
				0.10 - 90									5,000	2,500
	Dual Coil	80	DC	---	0.10 - 30	---	---	7,500	---	1,500	5,000	1,500	TC1,2,OL1,U1	---
		250	50 / 60	1 & 3										5,000
Shunt	80	DC	---	0.10 - 70	---	---	7,500	---	5,000	5,000	1,500	TC1,2,OL1,U1	---	
	250	50 / 60	1 & 3										5,000	3,000
	415			50 / 60	3	0.10 - 30	5,000 ²	---	5,000	2,500	3,000	---	TC1,2,OL1,C1	Rocker
		0.10 - 30	5,000			2,500								3,000

Notes:

- General Purpose ratings for UL/CSA only.
- Requires branch circuit backup with a UL LISTED Type K5 or RK5 fuse rated 15A minimum and no more than 4 times full load amps not to exceed 125A for 50 Amp or less rating and not to exceed 175 for 51 through 100 Amp rating.

Table D: Lists UL Listed (489), CSA Certified (C22.2 No. 5.1-M) configuration and performance capabilities as a Molded Case Circuit Breaker.

UL489 Listed Branch Circuit Breakers							
Circuit Configuration	Voltage			Current Rating	Interrupting Capacity (Amps)	Construction Notes	
	Max. Rating	Frequency	Phase	Full Load Amps	Without Backup Fuse		
Series	80	DC	---	0.10 - 100	50,000 ¹	Limited to 2 Poles Max from 71 - 100 Amps	
				101 - 150	10,000		2 Poles - Parallel Poles
				151 - 250	10,000		3 Poles - Parallel Poles
	125	50 / 60	1	0.10 - 100	5,000	1 - 3 Poles	
				125 / 250	10,000	1 or 2 Poles (2 poles required for 250 Volts)	
	120	50 / 60	1	0.10 - 50	10,000	1 - 3 Poles	
				51 - 70	5,000		
	120 / 240	50 / 60	1	0.10 - 50	10,000 ¹	2 or 3 Poles (1 pole of a 3 pole unit is neutral)	
				0.10 - 30	5,000		
	240	50 / 60	1	0.10 - 30	5,000	1 Pole	
0.10 - 20				10,000	2 Poles		
277	50 / 60	1	0.10 - 20	10,000	1-2 Poles		
			0.10 - 30	10,000	---		
Dual Coil	120	50 / 60	1	0.10 - 30	10,000	---	

Notes:

- Special catalog number required. Consult factory.

Tech Specs

Tables

Table E: Lists UL Recognized, CSA Accepted configurations and performance capabilities as Protectors, Supplementary for Marine Electrical and Fuel Systems (Guide PEQ22, File E75596). Ignition Protected per UL 1500. UL Classified Small Craft Electrical Devices, Marine in accordance with ISO 8846 (Guide UZMK, File MQ1515) as Marine Supplementary Protectors.

UL1500 (Marine Ignition Protection)								
Circuit Configuration	Voltage			Current Rating Full Load Amps	Interrupting Capacity (Amps) Without Backup Fuse	Application Codes		Construction Notes
	Max Rating	Frequency	Phase			UL	CSA	
Series	48	DC	---	0.02 - 100	5,000	TCI, 2, OLI, UI	TCI, 2, OLI, UI	---
	65			101 - 150				
	80			0.02 - 100	1,500	TCI, 2, OLO, UI	TCI, 2, OLO, UI	
	125	50 / 60	1	0.02 - 70		5,000	TCI, 2, OLI, UI	
	250			71 - 100	1,500		TCI, 2, OLI, UI	
				0.02 - 70		TCI, 2, OLI, UI	TCI, 2, OLI, UI	
				71 - 100		TCI, 2, OLI, UI	TCI, 2, OLI, UI	

Table F: Lists UL Listed configurations and performance capabilities as Circuit Breakers for use in Communications Equipment (Guide DITT, File E189195), under UL489A.

PARALLEL POLE CONSTRUCTION UL489A Listed for Communications Equipment				
Circuit Configuration	Voltage		Current Rating	Interrupting Capacity (Amps)
	Max. Rating	Frequency	General Purpose Amps	Without Backup Fuse
Series	80	DC	100 - 250	10,000

Time Delay Specs

To view all hydraulic-magnetic circuit breaker time delay values, please visit www.carlingtech.com/sites/default/files/documents/Carling-HM-CB-Time-Delays.pdf

Agency Approvals

UL 1077	Component Recognition Program as Protectors Supplementary (Guide CCN/QVNU2, File E75596)
UL 508	Switches, Industrial Control (Guide CCN/NRNT2, File E148683)
UL 1500	Protectors, Supplementary for Marine Electrical & Fuel Systems (Guide PEQ22, File E75596) Ignition Protection
UL 489	Circuit Breakers, Molded Case, (Guide DIVQ, File E129899)
UL 489A	Communications Equipment (Guide CCN/DITT, File E189195)
CSA Accepted	Component Supplementary Protector under Class 3215 30, File 047848 0 000 CSA Standard C22.2 No. 235
CSA Certified	Circuit Breaker Model Case (Class 1432 01, File 093910), CSA Standard C22.2 No. 5.1 - M
TUV Certified	EN60934, under License No. R72040875
VDE Certified	EN60934, VDE 0642 under File No. 10537

Ordering Scheme Handle - UL 1077 Recognized

Sample Part Number **C A 3 - B 0 - 10 - 450 - 1 2 1 - C**

Selection 1 2 3 4 5 6 7 8 9 10 11

1. SERIES

C

2. ACTUATOR ¹

- A Handle, one per pole
- B Handle, one per multipole unit
- S Mid-Trip Handle, one per pole
- T Mid-Trip Handle, one per pole & Alarm Switch

3. POLES ²

- | | | |
|-------|---------|--------|
| 1 One | 3 Three | 5 Five |
| 2 Two | 4 Four | 6 Six |

4. CIRCUIT ³

- | | |
|--------------------------------------|---|
| A ³ Switch Only (No Coil) | G ⁴ Relay Trip (voltage) |
| B Series Trip (Current) | H ^{4,5} Dual Coil with Shunt Trip Voltage Coil |
| C Series Trip (voltage) | K ^{4,5} Dual Coil with Relay Trip Voltage Coil |
| D ⁴ Shunt Trip (Current) | |
| E ⁴ Shunt Trip (voltage) | |
| F ⁴ Relay Trip (Current) | |

5. AUXILIARY / ALARM SWITCH ⁵

- | | |
|-------------------------------|-------------------------------|
| 0 without Aux Switch | 7 S.P.S.T., 0.139 Solder Lug. |
| 2 S.P.D.T., 0.110 Q.C. Term. | (Gold Contacts) |
| 3 S.P.D.T., 0.139 Solder Lug. | 8 S.P.S.T., 0.187 Q.C. Term. |
| 4 S.P.S.T., 0.093 Q.C. Term. | 9 S.P.D.T., 0.187 Q.C. Term. |

6. FREQUENCY & DELAY

- | | |
|------------------------------|---|
| 03 DC 50/60Hz, Switch Only | 31 DC, 50/60Hz Ultra Short |
| 10 DC Instantaneous | 32 DC, 50/60Hz Short |
| 11 DC Ultra Short | 34 DC, 50/60Hz Medium |
| 12 DC Short | 36 DC, 50/60Hz Long |
| 14 DC Medium | 42 ⁸ 50/60Hz Short, High-inrush |
| 16 DC Long | 44 ⁸ 50/60Hz Medium, High-inrush |
| 20 50/60Hz Instantaneous | 46 ⁸ 50/60Hz Long, High-inrush |
| 21 50/60Hz Ultra Short | 52 ⁸ DC, Short, High-inrush |
| 22 50/60Hz Short | 54 ⁸ DC, Medium, High-inrush |
| 24 50/60Hz Medium | 56 DC, Long, High-inrush |
| 26 50/60Hz Long | |
| 30 DC, 50/60Hz Instantaneous | |

Notes:

- 1 Actuator Code:
A: Handle tie pin spacer(s) and retainers provided assembled with multipole units. B: Handle location as viewed from front of breaker.
2 pole - left pole 3 pole - center pole 4 pole - two handles at center poles 5 pole - three handles at center poles 6 pole - four handles at center poles
S: Handle moves to mid-position only upon electrical trip of the breaker. Available with circuit codes B, C, D, E, F, G, H and K.
T: Handle moves to mid-position and alarm switch activates only upon electrical trip of the breaker. Available with circuit codes B & C.
- 2 Standard multipole units have all poles identical except when specifying auxiliary switch and/or mixed poles. 4 pole max with VDE. 5th pole available as Series Trip with Voltage Coil only.
- 3 Switch Only circuits, rated up to 50 amps and 6 poles, and only available with VDE Certification when tied to a protected pole (Circuit Code B, C, D or H). For .02 to 30 amps, select Current Code 630. For 35 - 50 amps, select Current Code 650. For 55-70 amps, select Current Code 670. For 75-100 amps, select Current Code 810.
- 4 Circuit Codes D,E,F,G,H & K available with Terminal Codes 1,2,4 & 5 only. Circuit Codes D, F, H & K available up to 50 amps maximum Current Rating.
- 5 Consult factory for available Dual Coil options, as special catalog number is required. Dual Coil Voltage Coils with Shunt Trip Construction trip instantaneously on line voltage. Dual Coil Voltage Coils require 30VA minimum power to trip instantaneously and are rated for intermittent duty only.
- 6 Auxiliary Switch available with Series Trip & Switch Only circuits. On multi-pole breakers, one auxiliary switch is supplied, mounted in the extreme right pole. Voltage coils not rated for continuous duty. Available only with delay codes 10 & 20.
- 8 Available with Circuit Codes B & D only, and up to 50 amps maximum.
- 9 Current Ratings 60 - 70 are available up to four poles maximum. Ratings 71 - 100 are available up to two poles maximum.
- 10 Terminal Code I available to 60 amps maximum.
- 11 Terminal Codes 2, 4, 5 and C available to 50 amps maximum.
- 12 Terminal Codes 3, 6 & 9 available to 100 amps maximum.
- 13 Terminal Code 7 available to 25 amps maximum.
- 14 Terminal Code A available to 100 amps maximum.
- 15 Terminal Codes 7, 9 & C are not VDE approved.
- 16 No marking available. Consult factory. VDE/TUV Approval requires dual (I-O, ON-OFF) or I-O markings on all handles.
- 17 Single pole only.
- 18 VDE/TUV: 30 amps max.; UL/CSA: 50 amps max.; Available in 2 - 4 poles only and limited to AC Delays. "General Purpose amps" not rated for "full load amps" or to be used in applications with a motor.

7. CURRENT RATING (AMPERES)

CODE	AMPERES	CODE	AMPERES	CODE	AMPERES	CODE	AMPERES
020	0.020	235	0.350	430	3.000	614	14.000
025	0.025	240	0.400	435	3.500	615	15.000
030	0.030	245	0.450	440	4.000	616	16.000
035	0.035	250	0.500	445	4.500	617	17.000
040	0.040	255	0.550	450	5.000	618	18.000
045	0.045	260	0.600	455	5.500	620	20.000
050	0.050	265	0.650	460	6.000	622	22.000
055	0.055	270	0.700	465	6.500	624	24.000
060	0.060	275	0.750	470	7.000	625	25.000
065	0.065	280	0.800	475	7.500	630	30.000
070	0.070	285	0.850	480	8.000	635	35.000
075	0.075	290	0.900	485	8.500	640	40.000
080	0.080	295	0.950	490	9.000	650	50.000
085	0.085	410	1.000	495	9.500	660 ⁹	60.000
090	0.090	512	1.250	610	10.000	670 ⁹	70.000
095	0.095	415	1.500	710	10.500	680 ⁹	80.000
210	0.100	517	1.750	611	11.000	685 ⁹	85.000
215	0.150	420	2.000	711	11.500	690 ⁹	90.000
220	0.200	522	2.250	612	12.000	695 ⁹	95.000
225	0.250	425	2.500	712	12.500	810 ⁹	100.000
230	0.300	527	2.750	613	13.000		

OR VOLTAGE COIL (NORMAL RATED VOLTAGE) ⁷

CODE	AMPERES	CODE	AMPERES	CODE	AMPERES	CODE	AMPERES
A06	6 DC	A32	32 DC	J12	12 AC	J65	65 AC
A12	12 DC	A48	48 DC	J18	18 AC	K20	120 AC
A18	18 DC	A65	65 DC	J24	24 AC	L40	240 AC
A24	24 DC	J06	6 AC	J48	48 AC		

8. TERMINAL ¹⁵

- | | |
|--------------------------------|---|
| 1 ¹⁰ Stud 10-32 | 6 ¹² Stud M6 |
| 2 ¹¹ Screw 10-32 | 7 ^{13,15} 0.250 Double Click Connect |
| 3 ¹² Stud 1/4-20 | 9 ¹⁵ 7/16" Clip Terminal |
| 4 ¹¹ Stud M5 x 0.8 | A ¹⁴ Plug-In Stud |
| 5 ¹¹ Screw M5 x 0.8 | C ^{11,15} 5/16" Clip Terminal |

9. ACTUATOR COLOR & LEGEND ¹⁶

Actuator Color	I-O	ON-OFF	Dual	Legend Color
White	A	B	1	Black
Black	C	D	2	White
Red	F	G	3	White
Green	H	J	4	White
Blue	K	L	5	White
Yellow	M	N	6	Black
Gray	P	Q	7	Black
Orange	R	S	8	Black
Black (short handle) ¹⁷	T	U	9	White

10. MOUNTING / BARRIERS

	MOUNTING STYLE	BARRIERS	VOLTAGE
1	Threaded Insert		
A	6-32 x 0.195 inches	no	< 300
C 18	6-32 X 0.195 inches	yes	< 300
2	6-32 X 0.195 inches	yes	≥ 300
B	ISO M3 x 5mm	no	< 300
D 18	ISO M3 x 5mm	yes	< 300
E 17	ISO M3 x 5mm	yes	≥ 300
	Front panel Snap-In, 1.00" [25.4mm] wide bezel with Handguard	no	< 300

11 AGENCY APPROVAL

- C UL Recognized, CSA Accepted
- D VDE Certified, UL Recognized, CSA Accepted
- E TUV Certified, UL Recognized, CSA Accepted
- H UL489 Construction: VDE Certified, UL Recognized, CSA Accepted
- I UL Recognized STD 1077, UL Recognized 1500 (ignition protected), CSA Accepted
- L UL489 Construction: UL Recognized, CSA Accepted
- R UL489 Construction: TUV Certified, UL Recognized, CSA Accepted

[Configure Complete Part Number >](#)

[Browse Standard Parts >](#)

Ordering Scheme

Handle - UL 489 & UL 489A Listed / Parallel Pole

Sample Part Number

C A 2 - P 0 - D4 - 820 - 3 2 1 - M T

Selection 1 2 3 4 5 6 7 8 9 10 11 12

1. SERIES

C

2. ACTUATOR 1

A Handle, one per pole
S Mid-Trip Handle, one per pole ¹
T Mid-Trip, one per pole & Alarm Switch ¹

3. POLES 4

1 One
2 Two
3 Three

4. CIRCUIT

P Series Trip (parallel pole)

5 AUXILIARY/ALARM SWITCH 2

0 without Aux Switch
2 S.P.D.T., 0.110 Q.C. Term.
3 S.P.D.T., 0.139 Solder Lug
4 S.P.D.T., 0.110 Q.C. Term. (Gold Contacts)
5 S.P.S.T., N.O., 0.110 Q.C Term. (Gold Contacts)
6 S.P.S.T., 0.139 Solder Lug
7 S.P.S.T., 0.110 Q.C Term. (Gold Contacts)
8 S.P.S.T., 0.187 Q.C. Term.
9 S.P.D.T., 0.187 Q.C. Term.

6. FREQUENCY & DELAY

D1 DC Ultra Short
D2 DC Short
D4 DC Medium
D6 DC Long

7. CURRENT RATING (AMPERES)

CODE	AMPERES				
810	100.00	813	130.00	817	170.00
811	110.00	814	140.00	917	175.00
812	120.00	815	150.00	818	180.00
912	125.00	816	160.00	819	190.00
				820	200.00
				922	225.00
				825	250.00

8. TERMINAL 4

3 1/4-20 threaded Stud
6 M6 threaded Stud
A Plug-in Stud ³

9 ACTUATOR COLOR & LEGEND

	Legend ON-OFF	Dual	Legend Color
White	B	1	Black
Black	D	2	White
Red	G	3	White
Green	J	4	White
Blue	L	5	White
Yellow	N	6	Black
Gray	Q	7	Black
Orange	S	8	Black

10. MOUNTING

Threaded Insert
1 6-32 x 0.195 inches
2 ISO M3 x 5mm

11. MAXIMUM APPLICATION RATING

M 80 DC

12. AGENCY APPROVAL

A Without Approval
G UL489 Listed
J UL489A Listed, TUV Certified
K UL489A Listed, VDE Certified
T UL489A Listed
7 UL489A Listed, TUV Certified

Notes:

- Handle moves to Mid-Position only upon electrical trip of C/B when Actuator S is specified. When Actuator Code T is specified, handle moves to Mid Position and Alarm Switch actuates only upon electrical trip of C/B. Code T is only available with Circuit Code N.
- Standard Handle colors are White, Black, Red & Yellow.
- Breakers with Terminal Codes 3 & 6 are supplied with bus bars connecting the Line and Load Terminals. For Terminal Code A, Line and Load Terminals must be connected to a copper bus bar having a minimum cross-section of 0.078 square inches. Terminal Code A is not available on the single pole unit.
- Ratings for 101 to 125 amps are available in 1-pole. Ratings from 110 to 200 amps are available in 2-pole. For ratings from 225-300 amps, specify 3-pole.
- 1 pole only available with terminal codes 3 and 6.
- Agency codes K and 7 are not available with 1 pole. Agency code J is only available with 1 pole. Agency code G is only available in 2 and 3 pole. Circuit P, ratings 101-150 amps (2 pole) and ratings 151-250 amps (3 pole).

[Configure Complete Part Number >](#)

[Browse Standard Parts >](#)

Ordering Scheme Handle - UL 489 Listed

Sample Part Number **C A 3 - B 0 - 14 - 450 - 1 2 1 - K G**

Selection 1 2 3 4 5 6 7 8 9 10 11 12

1. SERIES

C

2. ACTUATOR ¹

- A Handle, one per pole
- B Handle, one per multipole unit
- S Mid-Trip Handle, one per pole
- T Mid-Trip Handle, one per pole & Alarm Switch

3. POLES ²

- 1 One
- 2 Two
- 3 Three

4. CIRCUIT

B Series Trip (Current)

5 AUXILIARY/ALARM SWITCH ²

- | | |
|------------------------------|--|
| 0 without Aux Switch | 8 S.P.S.T., 0.187 Q.C. Term. |
| 2 S.P.D.T., 0.110 Q.C. Term. | 9 S.P.D.T., 0.187 Q.C. Term. (Gold Contacts) |
| 3 S.P.D.T., 0.139 Solder Lug | |
| 4 S.P.D.T., 0.110 Q.C. Term. | |
| 6 S.P.S.T., 0.139 Solder Lug | |

6. FREQUENCY & DELAY

- | | |
|------------------------|---|
| 11 DC Ultra Short | 26 50/60Hz Long |
| 12 DC Short | 42 ⁴ 50/60Hz Short, High-inrush |
| 14 DC Medium | 44 ⁴ 50/60Hz Medium, High-inrush |
| 16 DC Long | 46 ⁴ 50/60Hz Long, High-inrush |
| 21 50/60Hz Ultra Short | 52 ⁴ DC Short, High-inrush |
| 22 50/60Hz Short | 54 ⁴ DC Medium, High-inrush |
| 24 50/60Hz Medium | 56 ⁴ DC Long, High-inrush |

Notes:

- 1 Actuator Code:
A: Handle tie pin spacer(s) and retainers provided assembled with multipole units.
B: Handle located, as viewed from front of breaker in left pole. 2 pole maximum.
S: Handle moves to mid-position only upon electrical trip of the breaker.
T: Handle moves to mid-position and alarm switch activates only upon electrical trip of the breaker.
- 2 Standard multipole units have all poles identical except when specifying auxiliary switch and/or mixed poles. 2 & 3 pole circuit breakers required for 120/240 VAC (Maximum application rating code C) applications, have all poles identical except when specifying auxiliary /alarm switch which is normally supplied in extreme right pole per figure B. Terminal barriers are required on all multipole breakers. Third pole is for 120/240 VAC applications requiring neutral disconnect. The 3rd pole has the same construction as poles 1 & 2.
- 3 On multi-pole breakers, one auxiliary switch is supplied, mounted in the extreme right pole. VDE approval on auxiliary switch codes 2, 3 & 4 only. Auxiliary / Alarm Switch with Independent Circuit ie: separate from breaker circuit, only available with circuit breakers rated 50 amp maximum at 80 VDC, 125 VDC, and 120 VAC. Auxiliary / Alarm Switch with Dependent Circuit ie: same as circuit breaker, is supplied from factory with common terminal of auxiliary / alarm switch connected to line terminal on 120/240 and 240 VAC ratings. Circuit breakers rated 120 VAC 50 amp maximum can be supplied with Auxiliary/Alarm switch common terminal connected to breaker line terminal. Consult factory for special catalog number.
- 4 Available up to 50 amps maximum.
- 5 Current ratings 71 - 100 with VDE approvals are available up to two poles maximum.
- 6 Terminal Codes 9 & C are not VDE approved.
- 7 Terminal Code 1 available to 60 amps maximum.
- 8 Terminal Codes 2, 4, 5 & C available to 50 amps maximum.
- 9 Terminal Codes 3, 6 & 9 available to 100 amps maximum.
- 10 Terminal Code A available to 100 amps maximum.
- 11 VDE and TUV approvals require Dual (I-O, ON-OFF) markings on all handles.
- 12 Barriers supplied on multi-pole units only.

7. CURRENT RATING (AMPERES) ⁴

CODE	AMPERES						
210	0.100	295	0.950	470	7.000	618	18.000
215	0.150	410	1.000	475	7.500	620	20.000
220	0.200	512	1.250	480	8.000	622	22.000
225	0.250	415	1.500	485	8.500	624	24.000
230	0.300	517	1.750	490	9.000	625	25.000
235	0.350	420	2.000	495	9.500	630	30.000
240	0.400	522	2.250	610	10.000	635	35.000
245	0.450	425	2.500	710	10.500	640	40.000
250	0.500	527	2.750	611	11.000	660	60.000
255	0.550	430	3.000	711	11.500	670	70.000
260	0.600	435	3.500	612	12.000	680	80.000
265	0.650	440	4.000	712	12.500	685	85.000
270	0.700	445	4.500	613	13.000	690	90.000
275	0.750	450	5.000	614	14.000	695	95.000
280	0.800	455	5.500	615	15.000	810	100.000
285	0.850	460	6.000	616	16.000		
290	0.900	465	6.500	617	17.000		

8. TERMINAL ⁶

- | | |
|-------------------------------|------------------------------------|
| 1 ⁷ Stud 10-32 | 6 ⁹ Stud M6 |
| 2 ⁸ Screw 10-32 | 9 ⁹ 7/16" Clip Terminal |
| 3 ⁹ Stud 1/4-20 | A ¹⁰ Plug-In Stud |
| 4 ⁸ Stud M5 x 0.8 | C ⁸ 5/16" Clip Terminal |
| 5 ⁸ Screw M5 x 0.8 | |

9 ACTUATOR COLOR & LEGEND

Actuator Color	ON-OFF	Dual	Legend Color
White	B	1	Black
Black	D	2	White
Red	G	3	White
Green	J	4	White
Blue	L	5	White
Yellow	N	6	Black
Gray	Q	7	Black
Orange	S	8	Black

10. MOUNTING

	MOUNTING STYLE	BARRIERS ¹²
1	Threaded Insert	yes
2	6-32 x 0.195 inches	yes
	ISO M3 x 5mm	yes

11. MAXIMUM APPLICATION RATING

- B 125 DC
- C 120/240 AC ²
- D 240 AC
- K 120 AC
- F 277 AC
- M 80 DC

12. AGENCY APPROVAL ¹¹

- A without approvals
- F UL489 Listed, CSA Certified & VDE Certified
- G UL489 Listed & CSA Certified
- J UL489 Listed, CSA Certified & TUV Certified

[Configure Complete Part Number >](#)

[Browse Standard Parts >](#)

Circuit & Terminal Diagrams Handle

inches [millimeters]

DESCRIPTION	CODE	DIMENSIONAL DETAIL	RATING (AMPS)			
			25	50	80	100
#10-32 STUD	1		█	█	█	█
M5 STUD	4		█	█	█	█
#1/4-20 STUD	3		█	█	█	█
M6 STUD	6		█	█	█	█
#1/4-20 STUD	3		█	█	█	█
M6 STUD	6		█	█	█	█
#10-32 SCREW	2		█	█	█	█
M-5 SCREW	5		█	█	█	█

DESCRIPTION	CODE	DIMENSIONAL DETAIL	RATING (AMPS)			
			25	50	80	100
.250 DOUBLE Q.C.	7		█	█	█	█
7/16" CLIP TERMINALS	9		█	█	█	█
PUSH-IN STUD	A		█	█	█	█

NOTES: TOLERANCE ON STUD LENGTHS IS $\pm .031$ [$\pm .79$] UNLESS OTHERWISE SPECIFIED.

AUXILIARY / ALARM SWITCH TERMINAL DETAIL³

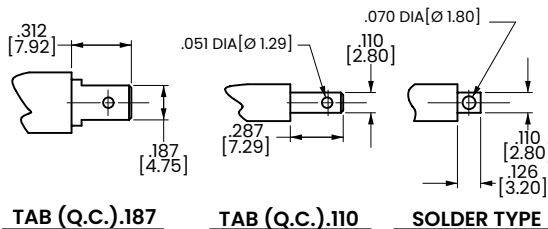

TIGHTENING TORQUE SPECIFICATIONS	
THREAD SIZE	TORQUE
#6-32 [M3] MOUNTING INSERTS	7-9 IN-LBS [0.8-1.0 NM]
#10-32 & M5 THD STUDS	15-20 IN-LBS [1.7-2.3 NM]
#10-32 THD SCREW	15-20 IN-LBS [1.7-2.3 NM]
#1/4-20 & M6 THD STUDS	30-35 IN-LBS [3.4-4.0 NM]

TERMINAL HARDWARE				
TERMINAL DESCRIPTION	CODE	AGENCY APPROVAL	AMPERE RATING	HARDWARE SUPPLIED
#10-32 STUD	1	ALL	.02-50	LOCK WASHER-FLAT WASHER-NUT
M5 STUD	4	ALL	.02-50	LOCK WASHER-FLAT WASHER-NUT
#1/4-20 STUD	3	ALL	.02-80	LOCK WASHER-FLAT WASHER-NUT
			81-100	LOCK WASHER-NUT-(2)FLAT WASHER-NUT
M6 STUD	6	ALL	.02-80	LOCK WASHER-FLAT WASHER-NUT
			81-100	LOCK WASHER-NUT-(2)FLAT WASHER-NUT
#10-32 SCREW	2 & 5	UL RECOGNIZED	.02-50	* SADDLE CLAMP-FLAT WASHER-SCREW
		UL-489 LISTED	.02-50	LOCK WASHER-FLAT WASHER-SCREW
		TUV & VDE CERTIFIED	.02-16	* SADDLE CLAMP-FLAT WASHER-SCREW
		TUV & VDE CERTIFIED	16.1-50	LOCK WASHER-FLAT WASHER-SCREW

* THE SADDLE CLAMP IS FOR DIRECT WIRE CONNECTION USE. DISCARD SADDLE CLAMP IF WIRE TERMINAL LUG IS USED

Notes:

- Tolerance $\pm .020$ [.51] unless otherwise specified.
- Available on Series Trip and Switch Only Circuits when called for on multi-pole units. Only one auxiliary switch is normally supplied, as viewed in multi-pole identification scheme.

Circuit & Terminal Diagrams Handle

inches [millimeters]

	CIRCUIT SCHEMATIC		CIRCUIT CODE	AUX. SWITCH CODE	CIRCUIT SCHEMATIC		CIRCUIT CODE	AUX. SWITCH CODE
	ANSI	IEC			ANSI	IEC		
	SWITCH ONLY (NO COIL)							
			A	0			B C	0
	SWITCH ONLY (NO COIL) WITH AUXILIARY SWITCH		A	2 3 4	SERIES TRIP WITH AUXILIARY/ALARM SWITCH		B C	2 3 4
	SHUNT TRIP		D E	0	DUAL COIL; SERIES TRIP CURRENT COIL, SHUNT TRIP VOLTAGE COIL		H	0
	RELAY TRIP		F G	0	DUAL COIL; SERIES TRIP CURRENT COIL, RELAY TRIP VOLTAGE COIL		K	0

HANDLE POSITION VS. AUX/ALARM SWITCH MODE					
CIRCUIT BREAKER MODE	STANDARD C/B		MID TRIP C/B		
	HANDLE POSITION	AUX. SWITCH MODE	HANDLE POSITION	STANDARD ALARM SWITCH MODE	REVERSE ALARM SWITCH MODE 4
OFF					
ON					
ELECTRICAL TRIP					

Notes:

- 1 Tolerance ± 0.020 [.51] unless otherwise specified.
- 2 Schematic shown represents current trip circuits.
- 3 Available only as special catalog number.

Dimensional Specs Handle

inches [millimeters]

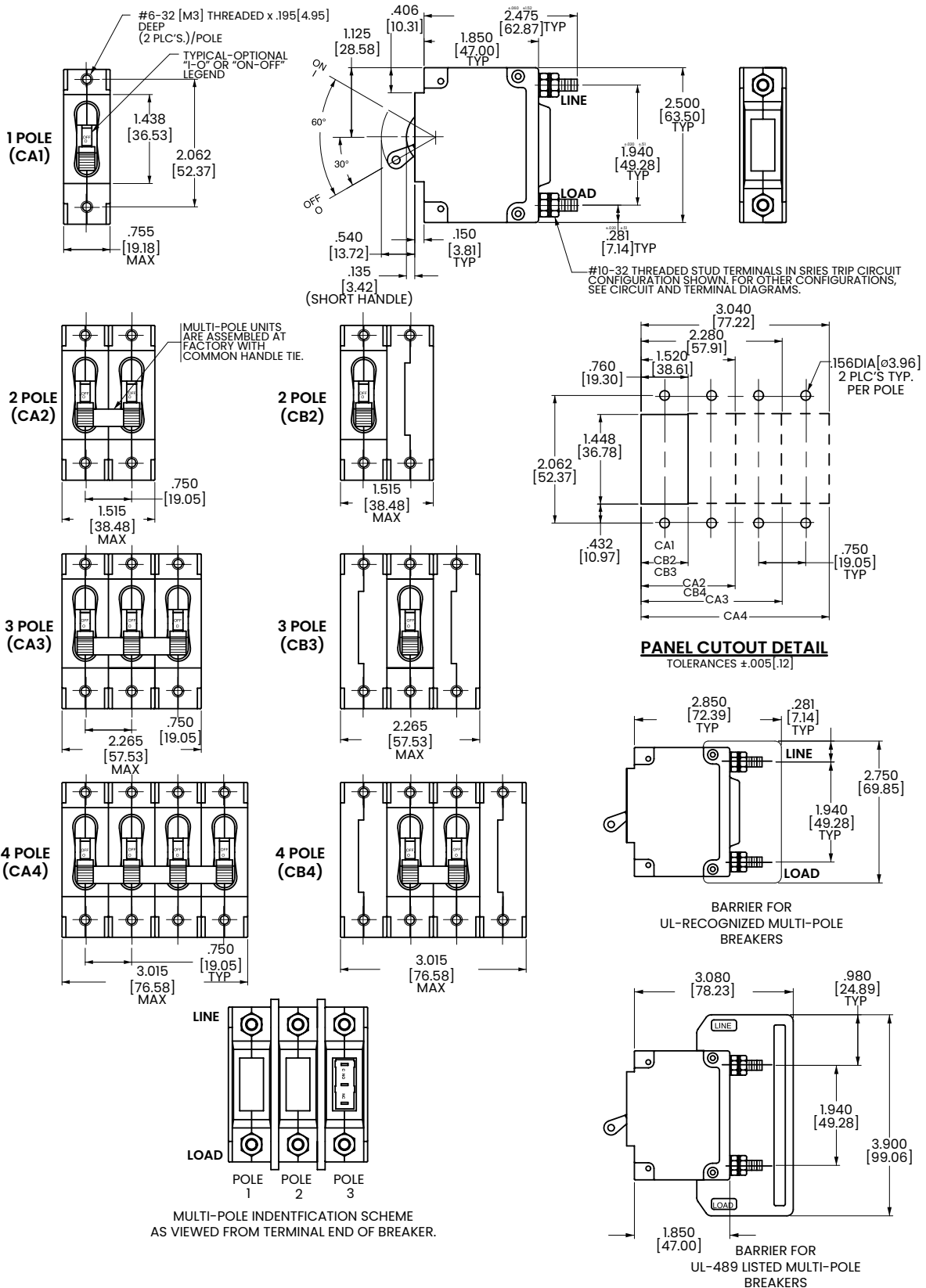

Notes:
1 Tolerance ±.020 [0.51] unless otherwise specified.

Dimensional Specs Handleguard

inches [millimeters]

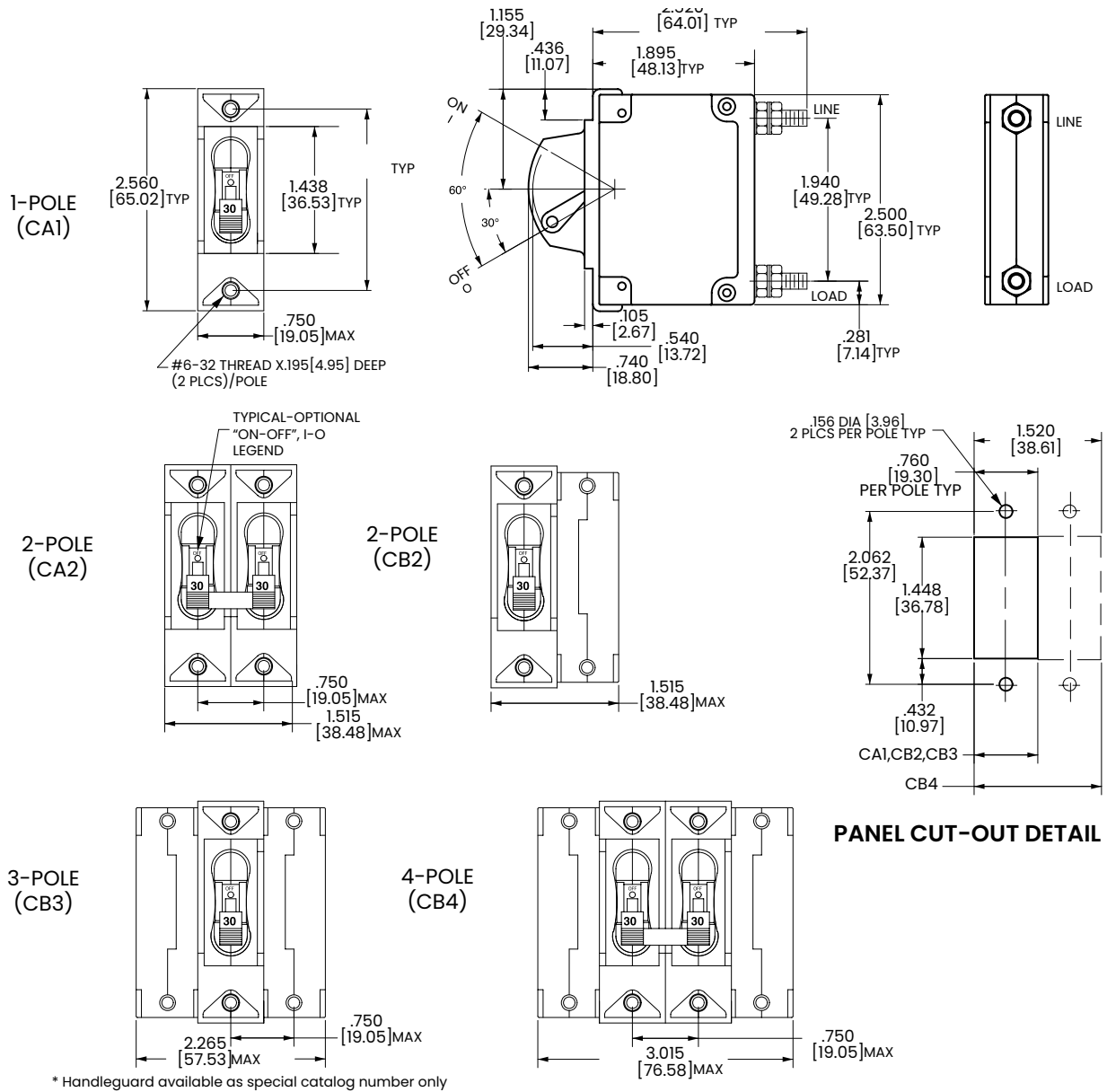

* Handleguard available as special catalog number only

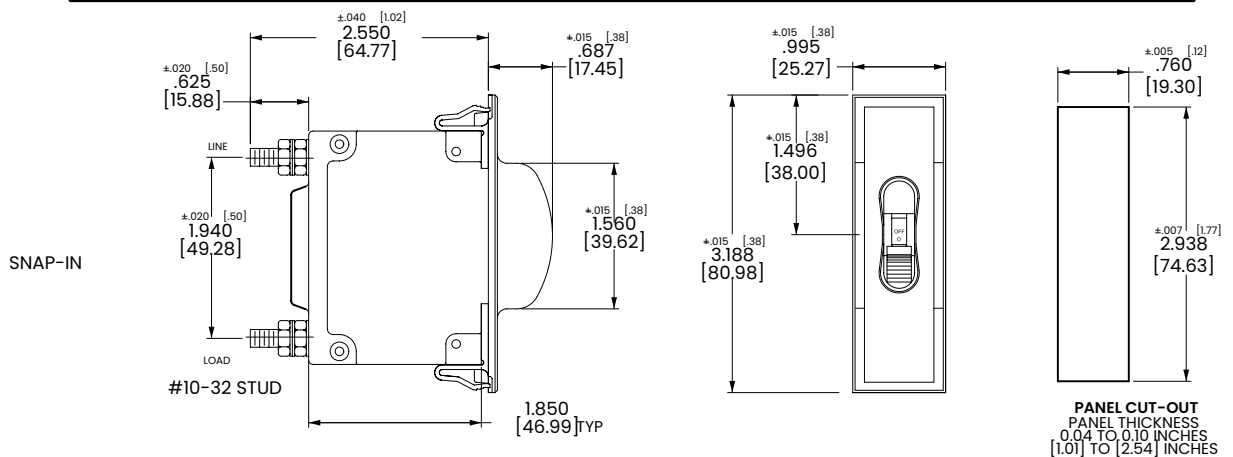

Notes:

1 Tolerance ±.020 [.51] unless otherwise specified.

Dimensional Specs Arc Chute Barrier

inches [millimeters]

1-POLE (CA1)
W/ ARC CHUTE BARRIER

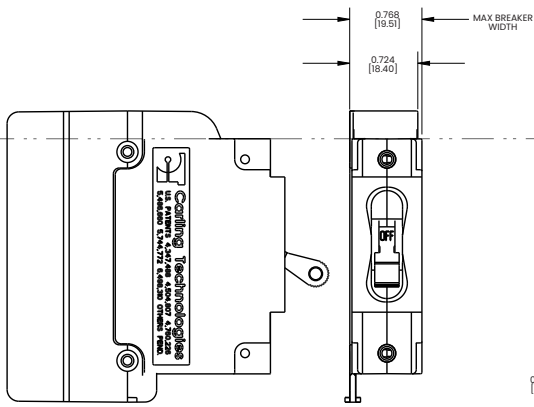

3-POLE (CA3)
W/ ARC CHUTE BARRIER

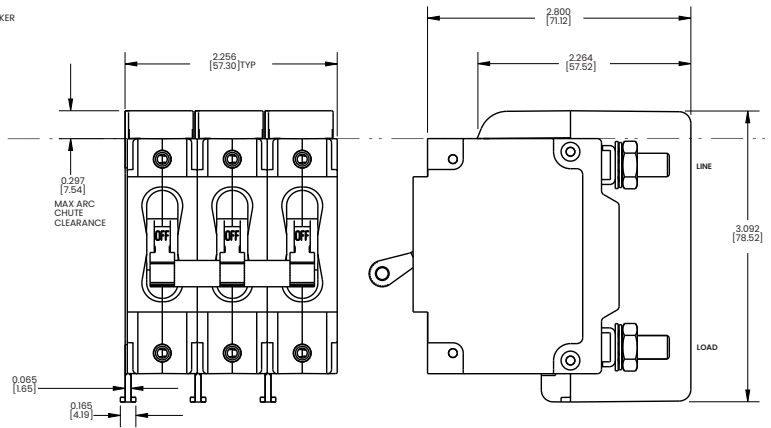

INDICATE "ON"

1-POLE (CC1, CD)
W/ ARC CHUTE (NO BARRIER)

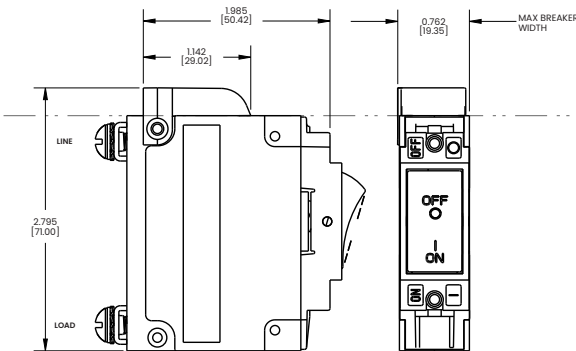

3-POLE (CC3, CD3)
W/ ARC CHUTE BARRIER

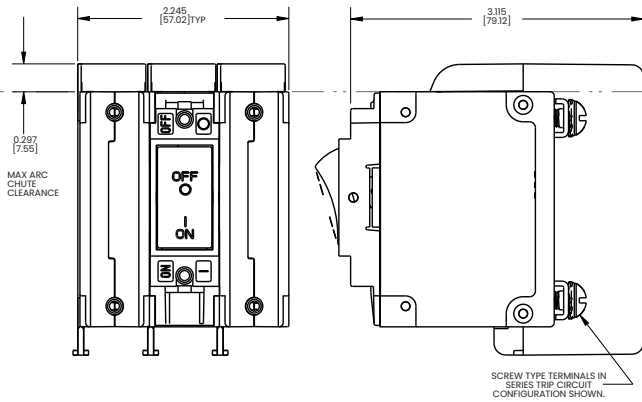

INDICATE "OFF" / SINGLE COLOR

1-POLE (CF1, CG1, C11, C21)
W/ ARC CHUTE (NO BARRIER)

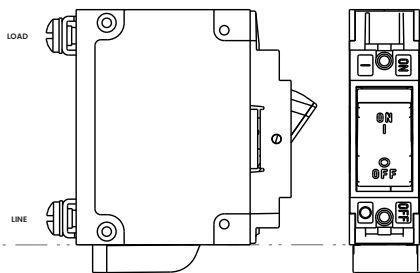

3-POLE (CF3, CG3, C13, C23)
W/ ARC CHUTE BARRIER

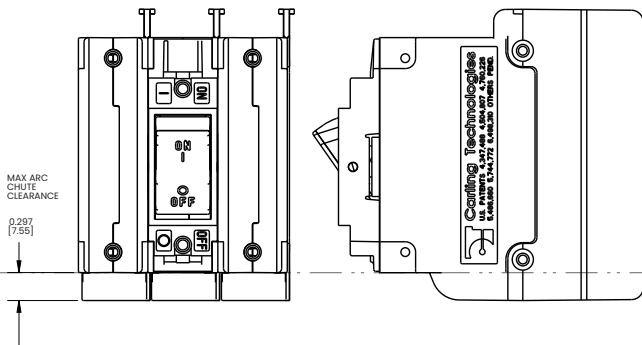

Notes:

- 1 Only 1-pole and 3-pole configurations shown. Arc chute (without barrier) and arc chute barrier also available for 2-pole construction.
- 2 Dimensions apply to all variations shown.
- 3 Notice that line and load terminal orientation for indicate on and indicate off rocker circuit breakers are opposite.
- 4 Screw type terminals shown for Rocker style (CF1, C11, etc) circuit breakers. For other terminal configurations see circuit and terminal diagrams.
- 5 Tolerance $\pm .020$ unless otherwise specified.
- 6 Must be ordered under a special catalog number.

Dimensional Specs Parallel Pole

inches [millimeters]

PARALLEL POLE (CA2-P)

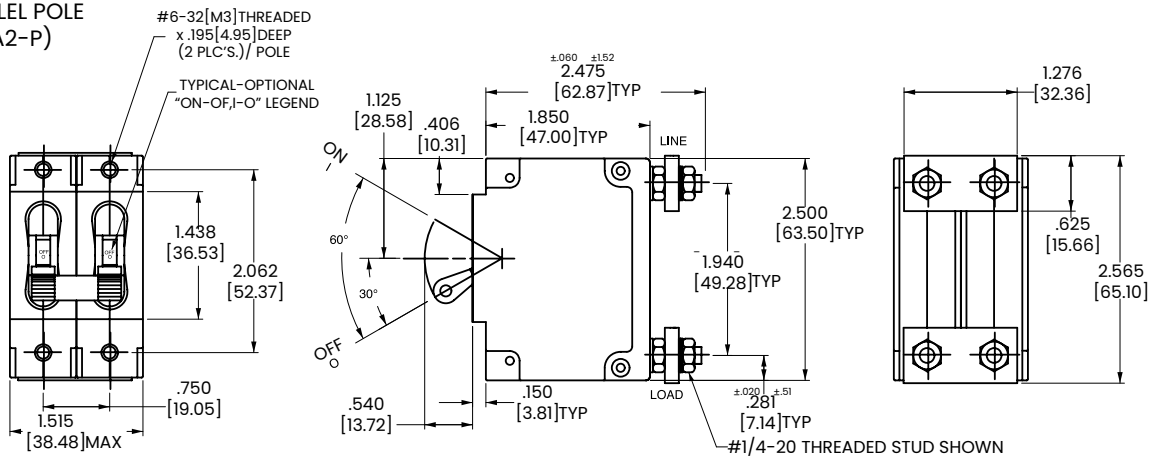

PARALLEL POLE (CA3-P)

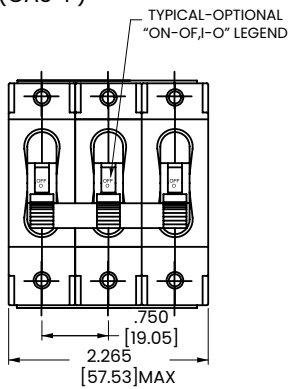

CIRCUIT BREAKER PROFILE	CIRCUIT SCHEMATIC (CA2-P SHOWN)		CIRCUIT CODE	SAFETY CODE
	ANSI	IEC		
	<p>SWITCH TRIP</p>		P	0
<p>PUSH-IN STUD</p>	<p>SERIES TRIP WITH AUXILIARY SWITCH</p>		P	2 3 4

TERMINAL DETAILS

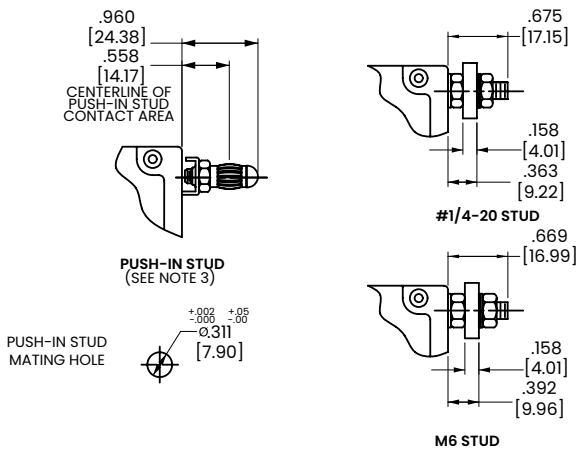

PANEL CUT-OUT DETAIL

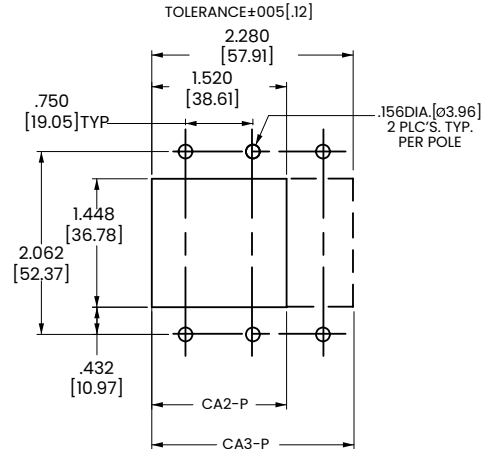

Notes:

- 1 Tolerance ±.020 [.51] unless otherwise specified.

Ordering Scheme

Sealed Toggle - UL 1077 Recognized

Sample Part Number

C M 3 - B 0 - 10 - 450 - 1 0 1 - C

Selection

1 2 3 4 5 6 7 8 9 10 11

1. SERIES

C

2. ACTUATOR ¹

M Sealed Toggle, one per pole

3. POLES

1 One 2 Two 3 Three

4. CIRCUIT

A ² Switch Only (no coil)	G ³ Relay Trip (voltage)
B Series Trip (current)	H ^{3,4} Dual Coil with Shunt Trip Voltage Coil
C Series Trip (voltage)	K ^{3,4} Dual Coil with Relay Trip Voltage Coil
D ³ Shunt Trip (current)	
E ³ Shunt Trip (voltage)	
F ³ Relay Trip (current)	

5. AUXILIARY / ALARM SWITCH ⁵

0 without Aux Switch	6 S.P.D.T., 0.139 Solder Lug
2 S.P.D.T., 0.110 Q.C. Term.	8 S.P.S.T., 0.187 Q.C. Term.
3 S.P.D.T., 0.139 Solder Lug	9 S.P.D.T., 0.187 Q.C. Term.
4 S.P.D.T., 0.110 Q.C. Term. (Gold Contacts)	

6. FREQUENCY & DELAY

03 ² DC 50/60Hz, Switch Only	30 DC 50/60Hz Instantaneous
10 ⁶ DC Instantaneous	31 DC 50/60Hz Ultra Short
11 DC Ultra Short	32 DC 50/60Hz Short
12 DC Short	34 DC 50/60Hz Medium
14 DC Medium	36 DC 50/60Hz Long
16 DC Long	42 ⁷ 50/60Hz Short, High-inrush
20 ⁶ 50/60Hz Instantaneous	44 ⁷ 50/60Hz Medium, High-inrush
21 50/60Hz Ultra Short	46 ⁷ 50/60Hz Long, High-inrush
22 50/60Hz Short	52 ⁷ DC Short, High-inrush
24 50/60Hz Medium	54 ⁷ DC Medium, High-inrush
26 50/60Hz Long	56 DC Long, High-inrush

Notes:

- Actuator Code M: Handle location as viewed from front of breaker:
2 pole - right pole 3 pole - center pole
- Switch Only circuits, rated up to 50 amps and 3 poles, and only available with VDE. For .02 to 30 amps, select Current Code 630. For 35 - 50 amps, select Current Code 650. For 55-70 amps, select Current Code 670. For 75-100 amps, select Current Code 810.
- Circuit Codes D,E,F,G,H & K available with Terminal Codes 1,2,4 & 5 only.
- Consult factory for available Dual Coil options, as special catalog number is required. Dual Coil Voltage Coils with Shunt Trip Construction trip instantaneously on line voltage. Dual Coil Voltage Coils require 30VA minimum power to trip instantaneously and are rated for intermittent duty only.
- Auxiliary Switch available with Series Trip and Switch Only circuits. On multipole breakers, one auxiliary switch is supplied, mounted in the extreme right pole.
- Voltage coils not rated for continuous duty. Available only with delay codes 10 & 20.
- Available with Circuit Codes B & D only, and up to 50 amps maximum.
- Consult factory for current ratings 71-100, in three pole units, available as special catalog number only.
- Terminal Code 1 available to 60 amps maximum.
- Terminal Codes 2, 4, 5 and C available to 50 amps maximum.
- Terminal Codes 3, 6 & 9 available to 100 amps maximum.
- Terminal Code 7 available to 25 amps maximum.
- Terminal Code A available to 100 amps maximum.

[Configure Complete Part Number >](#)

[Browse Standard Parts >](#)

7. CURRENT RATING (AMPERES) ⁹

CODE	AMPERES						
020	0.020	235	0.350	430	3.000	614	14.000
025	0.025	240	0.400	435	3.500	615	15.000
030	0.030	245	0.450	440	4.000	616	16.000
035	0.035	250	0.500	445	4.500	617	17.000
040	0.040	255	0.550	450	5.000	618	18.000
045	0.045	260	0.600	455	5.500	620	20.000
050	0.050	265	0.650	460	6.000	622	22.000
055	0.055	270	0.700	465	6.500	624	24.000
060	0.060	275	0.750	470	7.000	625	25.000
065	0.065	280	0.800	475	7.500	630	30.000
070	0.070	285	0.850	480	8.000	635	35.000
075	0.075	290	0.900	485	8.500	640	40.000
080	0.080	295	0.950	490	9.000	650	50.000
085	0.085	410	1.000	495	9.500	660	60.000
090	0.090	512	1.250	610	10.000	670	70.000
095	0.095	415	1.500	710	10.500	680	80.000
210	0.100	517	1.750	611	11.000	685	85.000
215	0.150	420	2.000	711	11.500	690	90.000
220	0.200	522	2.250	612	12.000	695	95.000
225	0.250	425	2.500	712	12.500	810	100.000
230	0.300	527	2.750	613	13.000		

OR VOLTAGE COIL (NORMAL RATED VOLTAGE) ⁶

A06 6 DC	A32 32 DC	J12 12 AC	J65 65 AC
A12 12 DC	A48 48 DC	J18 18 AC	K20 120 AC
A18 18 DC	A65 65 DC	J24 24 AC	L40 240 AC
A24 24 DC	J06 6 AC	J48 48 AC	

8. TERMINAL

1 Stud 10-32 ⁹	6 Stud M6 ¹¹
2 Screw 10-32 ¹⁰	7 0.250 Double Click Connect ¹²
3 Stud 1/4-20 ¹¹	9 7/16" Clip Terminal ¹¹
4 Stud M5 x 0.8 ¹⁰	A Plug-In Stud ¹³
5 Screw M5 x 0.8 ¹⁰	C 5/16" Clip Terminal ¹⁰

9. LEGEND PLATE

0 No Legend

10. MOUNTING / BARRIERS

	MOUNTING STYLE	BARRIERS
1	Standard Hex Nut	no
A	Standard Hex Nut (multi-pole units only)	yes

11 AGENCY APPROVAL

C	UL Recognized & CSA Accepted
I	UL Recognized & CSA Accepted, UL1500 ignition protection
L	UL Recognized & CSA Accepted with listed construction

Dimensional Specs Sealed Toggle

inches [millimeters]

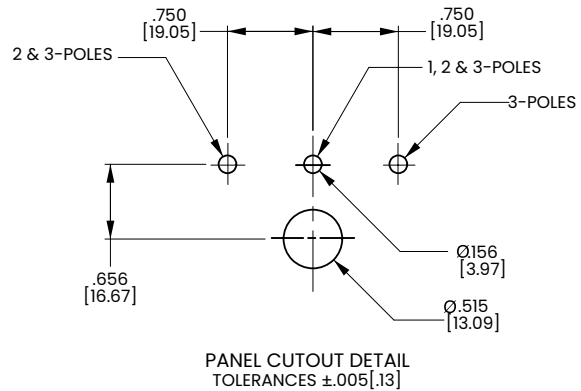
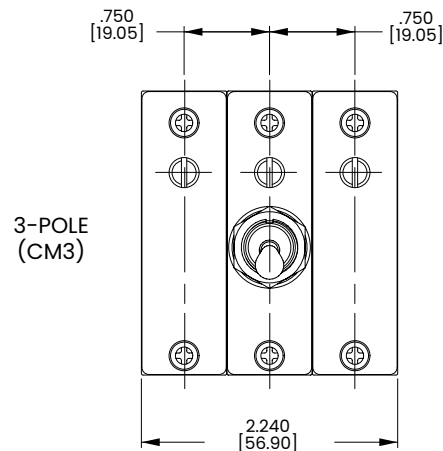
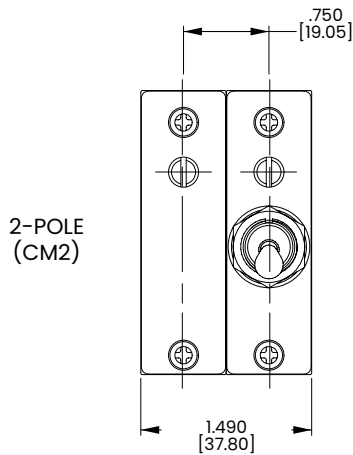
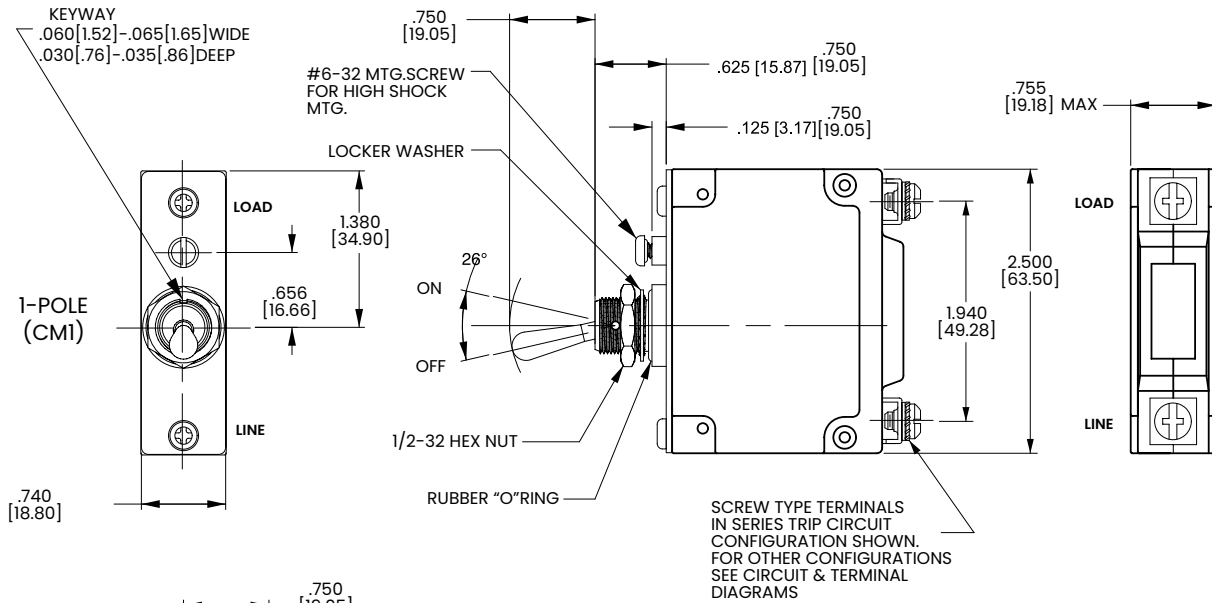

Notes:
 1 Tolerance ±.020 [.51] unless otherwise specified.

Ordering Scheme

Rocker - UL 1077 Recognized

Sample Part Number

C C 3 - B 0 - 14-450 - 1 2 1 - D

Selection 1 2 3 4 5 6 7 8 9 10 11

1. SERIES

C

2. ACTUATOR 1

Two Color Visi-Rocker

- C Indicate ON, vertical legend
- D Indicate ON, horizontal legend
- E Indicate ON, no legend
- F Indicate OFF, vertical legend
- G Indicate OFF, horizontal legend
- H Indicate OFF, no legend

Push-To-Reset, Visi-Rocker

- N Indicate OFF, vertical legend
- O Indicate OFF, horizontal legend
- P Indicate OFF, no legend

Single color

- J Vertical legend
- K Horizontal legend
- L No legend

Push-To-Reset, Single color

- R Vertical legend
- U Horizontal legend
- V No legend

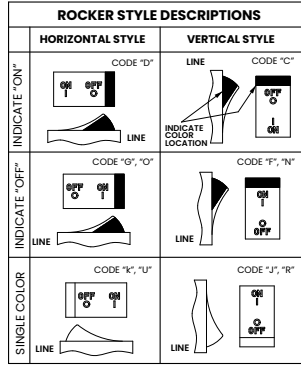

3. POLES 2

- 1 One 2 Two 3 Three

4. CIRCUIT

- F 4 Relay Trip (Current)
- A 3 Switch Only (No Coil)
- G 4 Relay Trip (Voltage)
- B Series Trip (Current)
- H 4,5 Dual Coil with Shunt Trip
- C Series Trip (Voltage)
- D 4 Voltage Coil
- D 4 Shunt Trip (Current)
- K 4,5 Dual Coil with Relay Trip
- E 4 Shunt Trip (Voltage)
- Voltage Coil

5. AUXILIARY / ALARM SWITCH 6

- 0 without Aux Switch
- 2 S.P.D.T., 0.110 Q.C. Term.
- 6 S.P.S.T., 0.139 Solder Lug
- 3 S.P.D.T., 0.139 Solder Lug
- 8 S.P.S.T., 0.187 Q.C. Term.
- 4 S.P.D.T., 0.110 Q.C. Term.
- 9 S.P.D.T., 0.187 Q.C. Term. (Gold Contacts)

6. FREQUENCY & DELAY

- 03 DC 50/60Hz, Switch Only
- 10 7 DC Instantaneous
- 11 DC Ultra Short
- 12 DC Short
- 14 DC Medium
- 16 DC Long
- 20 7 50/60Hz Instantaneous
- 21 50/60Hz Ultra Short
- 22 50/60Hz Short
- 24 50/60Hz Medium
- 26 50/60Hz Long
- 30 DC 50/60Hz Instantaneous
- 31 DC 50/60Hz Ultra Short
- 32 DC 50/60Hz Short
- 34 DC 50/60Hz Medium
- 36 DC 50/60Hz Long
- 42 8 50/60Hz Short, High-inrush
- 44 8 50/60Hz Medium, High-inrush
- 46 8 50/60Hz Long, High-inrush
- 52 8 DC Short, High-inrush
- 54 8 DC Medium, High-inrush
- 56 8 DC Long, High-inrush

Notes:

- 1 Push-To-Reset actuators have OFF portion of rocker shrouded.
- 2 Multi-pole breakers have all poles identical except when specifying Auxiliary switch and/or mixed poles, and have one rocker per breaker. Rocker location as viewed from front panel: 2 pole - left pole; 3 pole - center pole.
- 3 Switch Only circuits, rated up to 50 amps and 3 poles, and only available with VDE Certification when tied to a protected pole (Circuit Code B, C, D or H). For 02 to 30 amps, select Current Code 630. For 35 - 50 amps, select Current Code 650. For 55-70 amps, select Current Code 670. For 75-100 amps, select Current Code 810.
- 4 Circuit Codes D,E,F,G,H & K available with Terminal Codes 1,2,4 & 5 only. Circuit Codes D,F,H & K available up to 50 amps maximum Current Rating. Consult factory for available Dual Coil options, as special catalog number is required. Dual Coil Voltage Coils with Shunt Trip Construction trip instantaneously on line voltage. Dual Coil Voltage Coils require 30VA minimum power to trip instantaneously and are rated for intermittent duty only.
- 6 Auxiliary Switch available with Series Trip and Switch Only circuits. On multipole breakers, one auxiliary switch is supplied, mounted in the extreme right pole. Auxiliary switch codes 2, 3 & 4 are VDE approved. Voltage coils not rated for continuous duty. Available only with delay codes 10 & 20.
- 7 Available with Circuit Codes B & D only, and up to 50 amps maximum. Current Ratings 60-70 are available up to four poles maximum. Ratings 71-100 are available up to two poles maximum.
- 8 Terminal Code 1 available to 60 amps maximum.
- 9 Terminal Codes 2,4,5 & C available to 50 amps maximum.
- 10 Terminal Codes 3,6 & 9 available to 100 amps maximum.
- 11 Terminal Code 7 available to 25 amps maximum.
- 12 Terminal Code A available to 100 amps maximum.
- 13 Terminal Codes 7, 9 & C are not VDE approved.
- 14 Color shown is visi-legend with remainder of rocker black.
- 15 Legend on Push-to-Reset bezel/shroud is white when single color rocker is ordered. Dual = ON-OFF/I-O legend with actuator codes C - G, and J, K, N, O, R, & U. None = no legend with actuator codes H, L, P, V. Rockerguard available with actuator codes C - L. Push-to-Reset available with actuator codes N, O, P, R, U, V.
- 16 VDE/TUV approval requires Dual (I-O, ON-OFF) or I-O markings on rocker.
- 17 VDE/TUV: 30 amps max.; UL/CSA: 50 amps max.; Available in 2 - 4 poles only and limited to AC Delays. "General Purpose amps" not rated for "full load amps" or to be used in applications with a motor.

7. CURRENT RATING (AMPERES) 9

CODE	AMPERES	235	0.350	430	3.000	614	14.000
020	0.020	240	0.400	435	3.500	615	15.000
025	0.025	245	0.450	440	4.000	616	16.000
030	0.030	250	0.500	445	4.500	617	17.000
035	0.035	255	0.550	450	5.000	618	18.000
040	0.040	260	0.600	455	5.500	620	20.000
045	0.045	265	0.650	460	6.000	622	22.000
050	0.050	270	0.700	465	6.500	624	24.000
055	0.055	275	0.750	470	7.000	625	25.000
060	0.060	280	0.800	475	7.500	630	30.000
065	0.065	285	0.850	480	8.000	635	35.000
070	0.070	290	0.900	485	8.500	640	40.000
075	0.075	295	0.950	490	9.000	650	50.000
080	0.080	410	1.000	495	9.500	660 9	60.000
085	0.085	512	1.250	610	10.000	670 9	70.000
090	0.090	515	1.500	710	10.500	680 9	80.000
095	0.095	517	1.750	611	11.000	685 9	85.000
210	0.100	420	2.000	711	11.500	690 9	90.000
215	0.150	522	2.250	612	12.000	695 9	95.000
220	0.200	425	2.500	712	12.500	810 9	100.000
225	0.250	527	2.750	613	13.000		
230	0.300						

OR VOLTAGE COIL (NORMAL RATED VOLTAGE) 7

A06	6 DC	A32	32 DC	J12	12 AC	J65	65 AC
A12	12 DC	A48	48 DC	J18	18 AC	K20	120 AC
A18	18 DC	A65	65 DC	J24	24 AC	L40	240 AC
A24	24 DC	J06	6 AC	J48	48 AC		

8. TERMINAL

- 1 Stud 10-32 10
- 2 Screw 10-32 11
- 3 Stud 1/4-20 12
- 4 Stud M5 x 0.8 11
- 5 Screw M5 x 0.8 11
- 6 Stud M6 12
- 7 0.250 Double Click Connect 13
- 9 7/16" Clip Terminal
- A Plug-In Stud 14
- C 5/16" Clip Terminal

9. ACTUATOR COLOR & LEGEND 16,17,18

Actuator or Visi-Color	Marking:	Marking Color:	Single Color	Rocker/Handle	Visi-Rocker
Color:	I-O ON-OFF Dual/None				
White	A B 1		Black	White	White
Black	C D 2		White	n/a	n/a
Red	F G 3		White	Red	Red
Green	H J 4		White	Green	Green
Blue	K L 5		White	Blue	Blue
Yellow	M N 6		Black	Yellow	Yellow
Gray	P Q 7		Black	Gray	Gray
Orange	R S 8		Black	Orange	Orange

10 MOUNTING / BARRIERS 1

	STANDARD ROCKER BEZEL	BARRIERS	VOLTAGE
1	6-32 x 0.195 inches	no	<300
2	6-32 x 0.195 inches	yes	<300
3 19	6-32 x 0.195 inches	yes	≥300
4	ISO M3 x 5mm	no	<300
5	ISO M3 x 5mm	yes	<300
6 19	ISO M3 x 5mm	yes	≥300
ROCKERGUARD BEZEL			
A	6-32 x 0.195 inches	no	<300
C	6-32 x 0.195 inches	yes	<300
E 19	6-32 x 0.195 inches	yes	≥300
G	ISO M3 x 5mm	no	<300
J	ISO M3 x 5mm	yes	<300
L 19	ISO M3 x 5mm	yes	≥300
PUSH-TO-RESET BEZEL			
B	6-32 x 0.195 inches	no	<300
D	6-32 x 0.195 inches	yes	<300
F 19	6-32 x 0.195 inches	yes	≥300
H	ISO M3 x 5mm	no	<300
J	ISO M3 x 5mm	yes	<300
M 19	ISO M3 x 5mm	yes	≥300

11 AGENCY APPROVAL

C	UL Recognized & CSA Accepted
D	VDE Certified, UL Recognized & CSA Accepted
E	TUV Certified, UL Recognized & CSA Accepted
H	UL489 Construction: VDE Certified, UL Recognized & CSA Accepted
I	UL Recognized STD 1077, UL Recognized 1500 (ignition protected), & CSA Accepted
L	UL489 Construction: UL Recognized & CSA Accepted
R	UL489 Construction: TUV Certified, UL Recognized & CSA Accepted

Configure Complete Part Number >

Browse Standard Parts >

Ordering Scheme

Rocker - UL 489A Listed / Parallel Pole

Sample Part Number

C 1 2 - P 0 - D4 - 820 - 3 2 A - M T

Selection 1 2 3 4 5 6 7 8 9 10 11 12

1. SERIES

C

2. ACTUATOR ¹

- C** Curved Rocker, Two Color Visi, Indicate On, Vertical Legend
- D** Curved Rocker, Two Color Visi, Indicate On, Horizontal Legend
- F** Curved Rocker, Two Color Visi, Indicate Off, Vertical Legend
- G** Curved Rocker, Two Color Visi, Indicate Off, Horizontal Legend
- J** Curved Rocker, Single Color, Vertical Legend
- K** Curved Rocker, Single Color, Horizontal Legend
- N** Curved Rocker, Push To Reset, Two Color Visi, Vertical Legend
- O** Curved Rocker, Push To Reset, Two Color Visi, Horizontal Legend
- 1** Flat Rocker, Two Color Visi, Vertical Legend
- 2** Flat Rocker, Two Color Visi, Horizontal Legend
- 3** Flat Rocker, Single Color, Vertical Legend
- 4** Flat Rocker, Single Color, Horizontal Legend
- 5** Flat Rocker, Push To Reset, Two Color Visi, Vertical Legend
- 6** Flat Rocker, Push To Reset, Two Color Visi, Horizontal Legend
- 7** Flat Rocker, Push To Reset, Single Color, Vertical Legend
- 8** Flat Rocker, Push To Reset, Single Color, Horizontal Legend

3. POLES

- 1** One **2** Two **3** Three

4. CIRCUIT

- P** Series Trip (parallel pole)

5 AUXILIARY/ALARM SWITCH

- | | |
|---|---|
| 0 without Aux Switch | 6 S.P.S.T., 0.139 Solder Lug |
| 2 S.P.D.T., 0.110 Q.C. Term. | 7 S.P.S.T., 0.110 Q.C. Term. (Gold Contacts) |
| 3 S.P.D.T., 0.139 Solder Lug | 8 S.P.S.T., 0.187 Q.C. Term. (Gold Contacts) |
| 4 S.P.D.T., 0.110 Q.C. Term. (Gold Contacts) | 9 S.P.D.T., 0.187 Q.C. Term. (Gold Contacts) |
| 5 S.P.S.T., N.O., 0.110 Q.C. Term. (Gold Contacts) | |

6. FREQUENCY & DELAY

- D1** DC Ultra Short
- D2** DC Short
- D4** DC Medium
- D6** DC Long

7. CURRENT RATING (AMPERES) ²

CODE	AMPERES				
810	100.00	813	130.00	817	170.00
811	110.00	814	140.00	818	180.00
812	120.00	815	150.00	819	190.00
812	120.00	816	160.00	820	200.00
912	125.00			825	225.00
					250.00

8. TERMINAL ³

- 3** Stud 1/4-20
- 6** Stud M6
- A** Plug-In Stud ¹

9 ACTUATOR COLOR & LEGEND

Actuator Color	LEGEND	Dual	Legend Color
White	B ON-OFF	1	Black
Black	D	2	White
Red	G	3	White
Green	J	4	White
Blue	L	5	White
Yellow	N	6	Black
Gray	Q	7	Black
Orange	S	8	Black

10. MOUNTING

ROCKER / MOUNTING INSERT STYLE

- A** Standard Rocker Bezel - 6-32 Inserts
- B** Standard Rocker Bezel - M3 Inserts
- C** Rocker Guard Bezel - 6-32 Inserts
- D** Rocker Guard Bezel - M3 Inserts
- E** Standard Bezel with recessed Off Side Flat Rocker - 6-32 Inserts
- F** Standard Bezel with recessed Off Side Flat Rocker - M3 Inserts
- G** Push to Reset Bezel - 6-32 Inserts
- H** Push to Reset Bezel - M3 Inserts

11. MAXIMUM APPLICATION RATING

- M** 80 DC

12. AGENCY APPROVAL ⁴

- A** Without Approval
- G** UL489 Listed
- J** UL489A Listed, TUV Certified
- T** UL489A Listed
- 7** UL489A Listed, TUV Certified

Notes:

- 1** Breakers with Terminal Codes 3 & 6 are supplied with bus bars connecting the Line and Load Terminals. For Terminal Code A, Line and Load Terminals must be connected to a copper bus bar having a minimum cross-section of 0.078 square inches. Terminal Code A is not available on the single pole unit.
- 2** Ratings for 101 to 125 amps are available in 1-pole. Ratings from 110 to 200 amps are available in 2-pole. For ratings from 225-300 amps, specify 3-pole.
- 3** 1 pole only available with terminal codes 3 and 6.
- 4** Agency codes K and 7 are not available with 1 pole. Agency code J is only available with 1 pole. Agency code G is only available in 2 and 3 pole. Circuit P, ratings 101-150 amps (2 pole) and ratings 151-250 amps (3 pole).

[Configure Complete Part Number >](#)

[Browse Standard Parts >](#)

Ordering Scheme Rocker - UL 489 Listed

Sample Part Number **C C 3 - B 0 - 14 - 450 - 1 2 A - K G**

Selection 1 2 3 4 5 6 7 8 9 10 11 12

1. SERIES

C

2. ACTUATOR 1

Two Color Visi-Rocker
C Indicate ON, vertical legend
D Indicate ON, horizontal legend
F Indicate OFF, vertical legend
G Indicate OFF, horizontal legend

Single color
J Vertical legend
K Horizontal legend

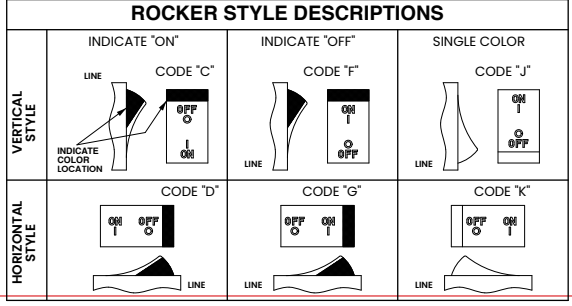

3. POLES 1

1 One **2** Two **3** Three

4. CIRCUIT

B Series Trip (current)

5 AUXILIARY/ALARM SWITCH 2

0 without Aux Switch	6 S.P.S.T., 0.139 Solder Lug
2 S.P.D.T., 0.110 Q.C. Term.	8 S.P.S.T., 0.187 Q.C. Term.
3 S.P.D.T., 0.139 Solder Lug	9 S.P.D.T., 0.187 Q.C. Term.
4 S.P.D.T., 0.110 Q.C. Term.	(Gold Contacts)

6. FREQUENCY & DELAY

11 DC Ultra Short	26 50/60Hz Long
12 DC Short	42 ⁸ 50/60Hz Short, High-inrush
14 DC Medium	44 ⁸ 50/60Hz Medium, High-inrush
16 DC Long	46 ⁸ 50/60Hz Long, High-inrush
21 50/60Hz Ultra Short	52 ⁸ DC Short, High-inrush
22 50/60Hz Short	54 ⁸ DC Medium, High-inrush
24 50/60Hz Medium	56 DC Long, High-inrush

- Notes:
- Multi-pole breakers have all breakers identical except when specifying Auxiliary switch and/or mixed poles, and have one rocker per breaker.
 - On multi-pole breakers, one auxiliary switch is supplied, mounted in the extreme right pole.
 - Available up to 50 amps maximum.
 - Current ratings 71 - 100 with VDE approvals are available up to two poles maximum.
 - Terminal Code 1 available to 60 amps maximum.
 - Terminal Codes 2, 4, 5 & C available to 50 amps maximum.
 - Terminal Codes 3, 6, 9 & A available to 100 amps maximum.
 - Terminal Codes 9 & C are not VDE approved.
 - Color shown is visi and legend with remainder of rocker black
 - Dual = ON-OFF/I-O legend on actuator.
 - VDE and TUV approval requires Dual (I-O, ON-OFF) markings on rocker.
 - Rockerguard available with all actuator codes.
 - Barriers supplied on multi-pole units only.
 - 2 & 3 pole circuit breakers required for 120/240 AC rating.

7. CURRENT RATING (AMPERES) 2

CODE	AMPERES	CODE	AMPERES	CODE	AMPERES	CODE	AMPERES
210	0.100	295	0.950	470	7.000	618	18.000
215	0.150	410	1.000	475	7.500	620	20.000
220	0.200	512	1.250	480	8.000	622	22.000
225	0.250	415	1.500	485	8.500	624	24.000
230	0.300	517	1.750	490	9.000	625	25.000
235	0.350	420	2.000	495	9.500	630	30.000
240	0.400	522	2.250	610	10.000	635	35.000
245	0.450	425	2.500	710	10.500	640	40.000
250	0.500	527	2.750	611	11.000	650	50.000
255	0.550	430	3.000	711	11.500	660	60.000
260	0.600	435	3.500	612	12.000	670	70.000
265	0.650	440	4.000	712	12.500	680	80.000
270	0.700	445	4.500	613	13.000	685	85.000
275	0.750	450	5.000	614	14.000	690	90.000
280	0.800	455	5.500	615	15.000	695	95.000
285	0.850	460	6.000	616	16.000	810	100.000
290	0.900	465	6.500	617	17.000		

8. TERMINAL 3

- | | |
|--|---|
| 1 Stud 10-32 ⁵ | 6 Stud M6 ⁷ |
| 2 Screw 10-32 with saddle ⁶ | 9 7/16" Clip Terminal & washer clamps ^{7,8} |
| 3 Stud 1/4-20 ⁷ | A Plug-In Stud ^{7,8} |
| 4 Stud M5 x 0.8 ⁶ | C 5/16" Clip Terminal ^{6,8} |
| 5 Screw M5 x 0.8 with saddle & washer clamps ⁶ | |

9. ACTUATOR COLOR & LEGEND

Actuator or Visi-Color	Marking:	Marking Color:	Single Color Rocker/Handle	Visi-Rocker
White	B ON-OFF	1 Dual ¹⁰	Black	White
Black	D	2	White	n/a
Red	G	3	White	Red
Green	J	4	White	Green
Blue	L	5	White	Blue
Yellow	N	6	Black	Yellow
Gray	Q	7	Black	Gray
Orange	S	8	Black	Orange

10. MOUNTING / BARRIERS 12

	Standard Rocker Bezel Threaded Insert, 2 per pole	BARRIERS ¹³
A	6-32 X 0.195 inches	yes
C	ISO M3 x 5mm	yes
	Rockerguard Bezel Threaded Insert, 2 per pole	
B	6-32 x 0.195 inches	yes
D	ISO M3 x 5mm	yes

11. MAXIMUM APPLICATION RATING

B	125 DC
C	120/240 AC ¹⁴
D	240 AC
F	277 AC
K	120 AC
M	80 DC

12. AGENCY APPROVAL

- | | |
|----------|---|
| A | without approvals |
| F | UL 489 Listed, CSA Certified, & VDE Certified |
| G | UL 489 Listed & CSA Certified |
| J | UL 489 Listed, CSA Certified & TUV Certified |

[Configure Complete Part Number >](#) [Browse Standard Parts >](#)

Circuit & Terminal Diagrams Rocker

inches [millimeters]

CIRCUIT BREAKER PROFILE	CIRCUIT SCHEMATIC		CIRCUIT CODE	AUX SWITCH CODE	CIRCUIT SCHEMATIC		CIRCUIT CODE	AUX SWITCH CODE
	ANSI	IEC			ANSI	IEC		
<p>SERIES TRIP (2 TERM'S.) ± 0.031 [±.79] 625 [5.88] TYP</p>	SWITCH ONLY (NO COIL) LINE LOAD LINE (NETZ) LOAD (LAST)		A	0	SWITCH TRIP LINE LOAD LINE (NETZ) (3) LOAD (LAST)		BC	0
<p>SERIES TRIP W/AUX. SWITCH (5 TERM'S.) 675 [17.15] TYP 970 [24.64] 1,265 [32.13] AUX. SWITCH TERM'S. (3 PLCS.)</p>	SWITCH ONLY (NO COIL) WITH AUXILIARY SWITCH LINE LOAD LINE (NETZ) LOAD (LAST)		A	2 3 4	SERIES TRIP WITH AUXILIARY SWITCH LINE LOAD LINE (NETZ) (3) LOAD (LAST)		BC	2 3 4
<p>SHUNT TRIP (3 TERM'S.)</p>	SHUNT TRIP LINE SHUNT LOAD LINE (NETZ) (3) SHUNT (NEBENSCHLUSS) LOAD (LAST)		DE	0	DUAL COIL: SERIES TRIP CURRENT COIL, SHUNT TRIP VOLTAGE COIL LINE SHUNT LOAD LINE (NETZ) SHUNT TRIP VOLTAGE COIL LOAD (LAST) VOLTAGE COIL		H	0
<p>SHUNT TRIP (4 TERM'S.) ± 0.031 [±.79] 812 [20.62] TYP 646 [16.41] TYP</p>	RELAY TRIP LINE LOAD RELAY RELAY LINE (NETZ) (3) RELAY (RELAIS) LOAD (LAST)		FG	0	DUAL COIL: SERIES TRIP CURRENT COIL, RELAY TRIP VOLTAGE COIL LINE LOAD RELAY RELAY LINE (NETZ) (3) RELAY (RELAIS) LOAD (LAST) VOLTAGE COIL VOLTAGE COIL		K	0

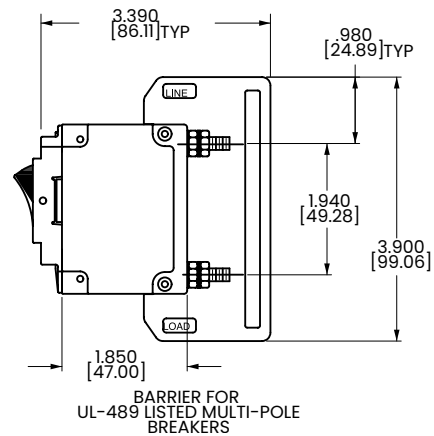
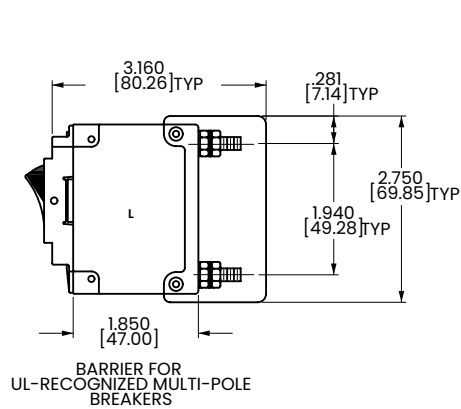

- Notes:
- 1 Tolerance ± 0.020 [.51] unless otherwise specified.
 - 2 Schematic shown represents current trip circuit.

Dimensional Specs Rocker

inches [millimeters]

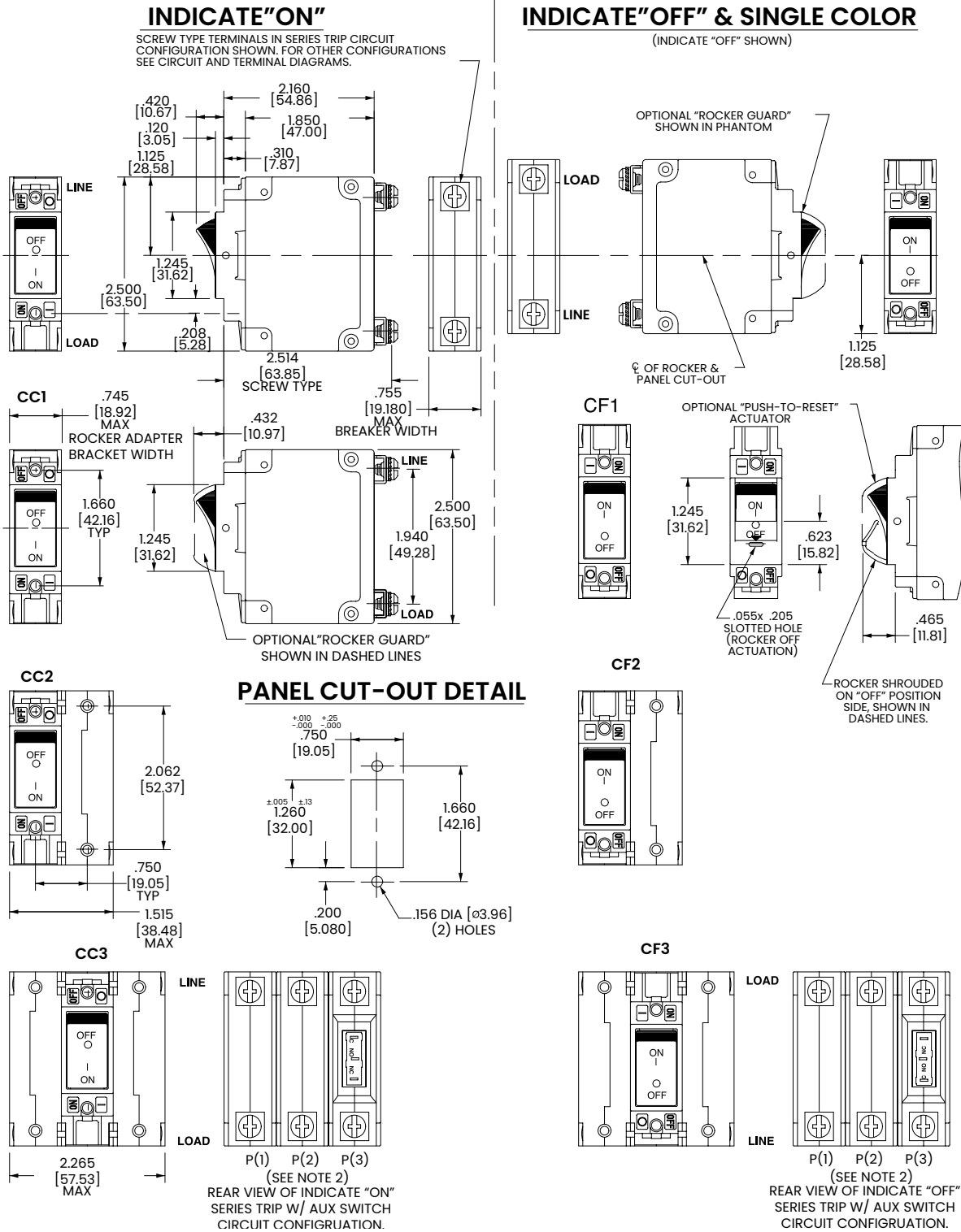

Notes:

- 1 Dimensions apply to all variations shown. Notice that circuit breaker line and load terminal orientation on indicate OFF is opposite of indicate ON.
- 2 For pole orientation with horizontal legend, rotate front view clockwise 90°.
- 3 Tolerance ±.020 [.51] unless otherwise specified.

Ordering Scheme

Flat Rocker - UL 1077 Recognized

Sample Part Number

C 1 2 - B 0 - 10-450 - 1 2 1 - E

Selection 1 2 3 4 5 6 7 8 9 10 11

1. SERIES

C

2. ACTUATOR ¹

- 1 Two Color Visi-Rocker
- 2 Indicate OFF, vertical legend
- 3 Indicate OFF, horizontal legend
- 4 Single color vertical legend
- 5 Single color horizontal legend
- 6 Push-To-Reset, Visi-Rocker
- 7 Indicate OFF, vertical legend
- 8 Indicate OFF, horizontal legend
- 9 Push-To-Reset, Single color vertical legend
- 10 Push-To-Reset, Single color horizontal legend

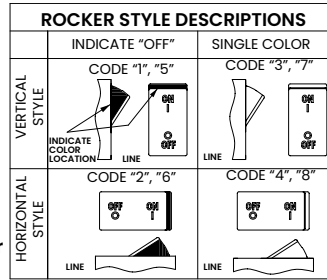

3. POLES ²

- 1 One 2 Two 3 Three

4. CIRCUIT

- | | |
|--|--|
| F ⁴ Relay Trip (Current) | D ⁴ Shunt Trip (Current) |
| A ³ Switch Only (No Coil) | K ^{4,5} Dual Coil with Relay Trip |
| G ⁴ Relay Trip (Voltage) | E ⁴ Shunt Trip (Voltage) |
| B Series Trip (Current) | Voltage Coil |
| H ^{4,5} Dual Coil with Shunt Trip | |
| C Series Trip (Voltage) | |
| Voltage Coil | |

5. AUXILIARY / ALARM SWITCH ⁶

- | | |
|--|------------------------------|
| 0 without Aux Switch | 6 S.P.S.T., 0.139 Solder Lug |
| 2 S.P.D.T., 0.110 Q.C. Term. | 8 S.P.S.T., 0.187 Q.C. Term. |
| 3 S.P.D.T., 0.139 Solder Lug | 9 S.P.D.T., 0.187 Q.C. Term. |
| 4 S.P.D.T., 0.110 Q.C. Term. (Gold Contacts) | |

6. FREQUENCY & DELAY

- | | |
|---------------------------------------|---|
| 03 DC 50/60Hz, Switch Only | 30 DC 50/60Hz Instantaneous |
| 10 ⁷ DC Instantaneous | 31 DC 50/60Hz Ultra Short |
| 11 DC Ultra Short | 32 DC 50/60Hz Short |
| 12 DC Short | 34 DC 50/60Hz Medium |
| 14 DC Medium | 36 DC 50/60Hz Long |
| 16 DC Long | 42 ⁸ 50/60Hz Short, High-inrush |
| 20 ⁷ 50/60Hz Instantaneous | 44 ⁸ 50/60Hz Medium, High-inrush |
| 21 50/60Hz Ultra Short | 46 ⁸ 50/60Hz Long, High-inrush |
| 22 50/60Hz Short | 52 ⁸ DC Short, High-inrush |
| 24 50/60Hz Medium | 54 ⁸ DC Medium, High-inrush |
| 26 50/60Hz Long | 56 ⁸ DC Long, High-inrush |

Notes:

- 1 Push-to-reset actuators have OFF portion of rocker shrouded.
- 2 Multi-pole breakers have all poles identical except when specifying Auxiliary switch and/or mixed poles, and have one rocker per breaker. Rocker location as viewed from front panel: 2 pole - left pole; 3 pole - center pole.
- 3 Switch Only circuits, rated up to 50 amps and 3 poles, and only available with VDE Certification when tied to a protected pole (Circuit Code B, C, D or H). For .02 to 30 amps, select Current Code 630. For 35 - 50 amps, select Current Code 650. For 55-70 amps, select Current Code 670. For 75-100 amps, select Current Code 810.
- 4 Circuit Codes D,E,F,G,H & K available with Terminal Codes 1,2,4 & 5 only. Circuit Codes D,F,H & K available up to 50 amps maximum Current Rating. Consult factory for available Dual Coil options, as special catalog number is required. Dual Coil Voltage Coils with Shunt Trip Construction trip instantaneously on line voltage. Dual Coil Voltage Coils require 30VA minimum power to trip instantaneously and are rated for intermittent duty only.
- 5 Auxiliary Switch available with Series Trip and Switch Only circuits. On multipole breakers, one auxiliary switch is supplied, mounted in the extreme right pole. Auxiliary switch codes 2, 3 & 4 are VDE approved.
- 6 Voltage coils not rated for continuous duty. Available only with delay codes 10 and 20.
- 7 Available with Circuit Codes B & D only, and up to 50 amps maximum.
- 8 Current ratings 60-70 are available up to four poles maximum. Current ratings 71 - 100 are available up to two poles maximum.
- 9 Terminal Code 1 available to 60 amps maximum.
- 10 Terminal Codes 2,4,5 & C available to 50 amps maximum.
- 11 Terminal Codes 3,6 & 9 available to 100 amps maximum.
- 12 Terminal Code 7 available to 25 amps maximum.
- 13 Terminal Code A available to 100 amps maximum.
- 14 Terminal Codes 7, 9 & C are not VDE approved.
- 15 Color shown is visi & legend with remainder of rocker black. Dual = ON-OFF/I-O legend.
- 16 Legend on Push-to-reset bezel/shroud is white with single color actuator codes 7 & 8. Legend on Push-to-reset bezel/shroud matches visi-color of rocker with actuator codes 5 & 6.
- 17 VDE/TUV approval requires Dual (I-O, ON-OFF) or I-O markings on rocker.
- 18 VDE/TUV: 30 amps max; UL/CSA: 50 amps max; Available in 2 & 3 poles only and limited to AC Delays. "General Purpose amps" not rated for "full load amps" or to be used in applications with a motor.
- 19 Recessed "OFF SLIDE" available with actuator codes 1,2,3&4. Legends on rocker are available in ink stamping only.

7. CURRENT RATING (AMPERES) ⁹

CODE	AMPERES						
020	0.020	235	0.350	430	3.000	614	14.000
025	0.025	240	0.400	435	3.500	615	15.000
030	0.030	245	0.450	440	4.000	616	16.000
035	0.035	250	0.500	445	4.500	617	17.000
040	0.040	255	0.550	450	5.000	618	18.000
045	0.045	260	0.600	455	5.500	620	20.000
050	0.050	265	0.650	460	6.000	622	22.000
055	0.055	270	0.700	465	6.500	624	24.000
060	0.060	275	0.750	470	7.000	625	25.000
065	0.065	280	0.800	475	7.500	630	30.000
070	0.070	285	0.850	480	8.000	635	35.000
075	0.075	290	0.900	485	8.500	640	40.000
080	0.080	295	0.950	490	9.000	650	50.000
085	0.085	410	1.000	495	9.500	660 ⁹	60.000
090	0.090	512	1.250	610	10.000	670 ⁹	70.000
095	0.095	415	1.500	710	10.500	680 ⁹	80.000
210	0.100	517	1.750	611	11.000	685 ⁹	85.000
215	0.150	420	2.000	711	11.500	690 ⁹	90.000
220	0.200	522	2.250	612	12.000	695 ⁹	95.000
225	0.250	425	2.500	712	12.500	810 ⁹	100.000
230	0.300	527	2.750	613	13.000		

OR VOLTAGE COIL (NORMAL RATED VOLTAGE) ⁷

A06	6 DC	A32	32 DC	J12	12 AC	J65	65 AC
A12	12 DC	A48	48 DC	J18	18 AC	K20	120 AC
A18	18 DC	A65	65 DC	J24	24 AC	L40	240 AC
A24	24 DC	J06	6 AC	J48	48 AC		

8. TERMINAL

- | | |
|---|--|
| 1 Stud 10-32 ¹⁰ | 6 Stud M6 ¹² |
| 2 Screw 10-32 with saddle ¹¹ | 9 7/16" Clip Terminal |
| 3 Stud 1/4-20 ¹² | 7 0.250 Double Click Connect ¹³ |
| 4 Stud M5 x 0.8 ¹¹ | A Plug-In Stud ¹⁴ |
| 5 Screw M5 x 0.8 ¹¹ | C 5/16" Clip Terminal |

9. ACTUATOR COLOR & LEGEND ^{16,17,18}

Actuator or Visi-Color	Marking:	Marking Color:	Single Color
Color:	I-O ON-OFF	Dual/None	Rocker/Handle Visi-Rocker
White	A B	1	Black White
Black	C D	2	White n/a
Red	F G	3	White Red
Green	H J	4	White Green
Blue	K L	5	White Blue
Yellow	M N	6	Black Yellow
Gray	P Q	7	Black Gray
Orange	R S	8	Black Orange

10 MOUNTING / BARRIERS ¹

STANDARD ROCKER BEZEL	BARRIERS	VOLTAGE
1 6-32 x 0.195 inches	no	<300
2 6-32 x 0.195 inches	yes	<300
3 ¹⁹ 6-32 x 0.195 inches	yes	≥300
4 ISO M3 x 5mm	no	<300
5 ISO M3 x 5mm	yes	<300
6 ¹⁹ ISO M3 x 5mm	yes	≥300
RECESSED OFF ROCKER		
7 6-32 x 0.195 inches	no	<300
8 6-32 x 0.195 inches	yes	<300
9 6-32 x 0.195 inches	yes	≥300
A ISO M3 x 5mm	no	<300
C ISO M3 x 5mm	yes	<300
E ISO M3 x 5mm	yes	≥300
PUSH-TO-RESET BEZEL		
B 6-32 x 0.195 inches	no	<300
D 6-32 x 0.195 inches	yes	<300
F ¹⁹ 6-32 x 0.195 inches	yes	≥300
H ISO M3 x 5mm	no	<300
J ISO M3 x 5mm	yes	<300
M ¹⁹ ISO M3 x 5mm	yes	≥300

11 AGENCY APPROVAL

- | | |
|---|---|
| C | UL Recognized & CSA Accepted |
| E | TUV Certified, UL Recognized & CSA Accepted |
| I | UL Recognized STD 1077, UL Recognized 1500 (ignition protected), & CSA Accepted |
| L | UL489 Construction: UL Recognized & CSA Accepted |
| R | UL489 Construction: TUV Certified, UL Recognized & CSA Accepted |

Configure Complete Part Number >

Browse Standard Parts >

Ordering Scheme Flat Rocker - UL 489 Listed

Sample Part Number **C 1 2 - B 0 - 14 - 450 - 1 2 A - K G**

Selection 1 2 3 4 5 6 7 8 9 10 11 12

1. SERIES

C

2. ACTUATOR 1

Two Color Visi-Rocker

- 1 Indicate OFF, vertical legend
- 2 Indicate OFF, horizontal legend

Single color

- 3 Vertical legend
- 4 Horizontal legend

Push-To-Reset, Visi-Rocker

- 5 Indicate OFF, vertical legend
- 6 Indicate OFF, horizontal legend

Push-To-Reset, Single color

- 7 Vertical legend
- 8 Horizontal legend

ROCKER STYLE DESCRIPTIONS

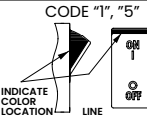
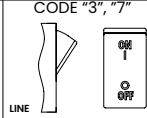
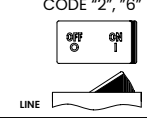
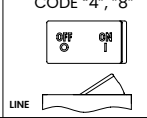
	INDICATE "OFF"	SINGLE COLOR
VERTICAL STYLE	 <p>CODE "1", "5"</p> <p>INDICATE COLOR LOCATION</p> <p>LINE</p>	 <p>CODE "3", "7"</p> <p>LINE</p>
HORIZONTAL STYLE	 <p>CODE "2", "6"</p> <p>LINE</p>	 <p>CODE "4", "8"</p> <p>LINE</p>

3. POLES 2

- 1 One
- 2 Two
- 3 Three

4. CIRCUIT

- B Series Trip (current)

5 AUXILIARY/ALARM SWITCH 2

- 0 without Aux Switch
- 2 S.P.D.T., 0.110 Q.C. Term.
- 3 S.P.D.T., 0.139 Solder Lug
- 4 S.P.D.T., 0.110 Q.C. Term. (Gold Contacts)
- 6 S.P.S.T., 0.139 Solder Lug
- 8 S.P.S.T., 0.187 Q.C. Term.
- 9 S.P.D.T., 0.187 Q.C. Term.

6. FREQUENCY & DELAY

- 11 DC Ultra Short
- 12 DC Short
- 14 DC Medium
- 16 DC Long
- 21 50/60Hz Ultra Short
- 22 50/60Hz Short
- 24 50/60Hz Medium
- 26 50/60Hz Long
- 42⁴ 50/60Hz Short, High-inrush
- 44⁴ 50/60Hz Medium, High-inrush
- 46⁴ 50/60Hz Long, High-inrush
- 52⁴ DC Short, High-inrush
- 54⁴ DC Medium, High-inrush
- 56⁴ DC Long, High-inrush

Notes:

- 1 Push-to-reset actuators have OFF portion of rocker shrouded.
- 2 Multi-pole breakers have all breakers identical except when specifying Auxiliary switch and/or mixed poles, and have one rocker per breaker.
- 3 On multi-pole breakers, one auxiliary switch is supplied, mounted in the extreme right pole.
- 4 Available up to 50 amps maximum.
- 5 Current ratings 71 - 100 with VDE approvals are available up to two poles maximum.
- 6 Terminal Code 1 available to 60 amps maximum.
- 7 Terminal Codes 2, 4, 5 & C available to 50 amps maximum.
- 8 Terminal Codes 3, 6, 9 & A available to 100 amps maximum.
- 9 Terminal Codes 9 & C are not VDE approved.
- 10 Color shown is visi and legend with remainder of rocker black
- 11 Dual = ON-OFF/I-O legend on actuator.
- 12 TUV approval requires Dual (I-O, ON-OFF) markings on rocker.
- 13 Legend on push-to-reset bezel/shroud is white when single color rocker is ordered. Legend on push-to-reset bezel/shroud matches visi-color of rocker with actuator codes 5 & 6.
- 14 Recessed "OFF-SIDE" available with actuator codes 1, 2, 3, & 4. Legends on rocker are available in ink stamping only.
- 15 Barriers supplied on multi-pole units only.
- 16 2 & 3 pole circuit breakers required for 120/240 AC rating.

7. CURRENT RATING (AMPERES) 5

CODE	AMPERES				
210	0.100	295	0.950	470	7.000
215	0.150	410	1.000	475	7.500
220	0.200	512	1.250	480	8.000
225	0.250	415	1.500	485	8.500
230	0.300	517	1.750	490	9.000
235	0.350	420	2.000	495	9.500
240	0.400	522	2.250	610	10.000
245	0.450	425	2.500	710	10.500
250	0.500	527	2.750	611	11.000
255	0.550	430	3.000	711	11.500
260	0.600	435	3.500	612	12.000
265	0.650	440	4.000	712	12.500
270	0.700	445	4.500	613	13.000
275	0.750	450	5.000	614	14.000
280	0.800	455	5.500	615	15.000
285	0.850	460	6.000	616	16.000
290	0.900	465	6.500	617	17.000
				618	18.000
				620	20.000
				622	22.000
				624	24.000
				625	25.000
				630	30.000
				635	35.000
				640	40.000
				650	50.000
				660	60.000
				670	70.000
				680	80.000
				685	85.000
				690	90.000
				695	95.000
				810	100.000

8. TERMINAL

- 1 Stud 10-32⁶
- 2 Screw 10-32 with saddle⁷
- 3 Stud 1/4-208
- 4 Stud M5 x 0.8⁷
- 5 Screw M5 x 0.8⁷
- 6 Stud M6⁸
- 9 7/16" Clip Terminal^{8,9}
- A Plug-In Stud⁸
- C 5/16" Clip Terminal^{7,9}

9 ACTUATOR COLOR & LEGEND 10

Actuator or Visi-Color	Marking:	Marking Color:	
			Single Color Rocker/Handle
Color:	ON-OFF	Dual ¹⁰	Visi-Rocker
White	B	1	White
Black	D	2	n/a
Red	G	3	Red
Green	J	4	Green
Blue	L	5	Blue
Yellow	N	6	Yellow
Gray	Q	7	Gray
Orange	S	8	Orange

10. MOUNTING / BARRIERS

	STANDARD ROCKER BEZEL Threaded Insert, 2 per pole	BARRIERS ¹⁵
A	6-32 X 0.195 inches	yes
C	ISO M3 x 5mm	yes
	RECESSED OFF ROCKER ¹⁴ Threaded Insert, 2 per pole	
E	6-32 x 0.195 inches	yes
F	ISO M3 x 5mm	yes
	PUSH-TO-RESET BEZEL ¹³ Threaded Insert, 2 per pole	
B	6-32 x 0.195 inches	yes
D	ISO M3 x 5mm	yes

11. MAXIMUM APPLICATION RATING

- B 125 DC
- C 120/240 AC¹⁶
- D 240 AC
- F 277 AC
- K 120 AC
- M 80 DC

12. AGENCY APPROVAL 12

- A without approvals
- G UL 489 Listed & CSA Certified
- J UL489 Listed, CSA Certified & TUV Certified

Configure Complete Part Number >

Browse Standard Parts >

Dimensional Specs Flat Rocker

inches [millimeters]

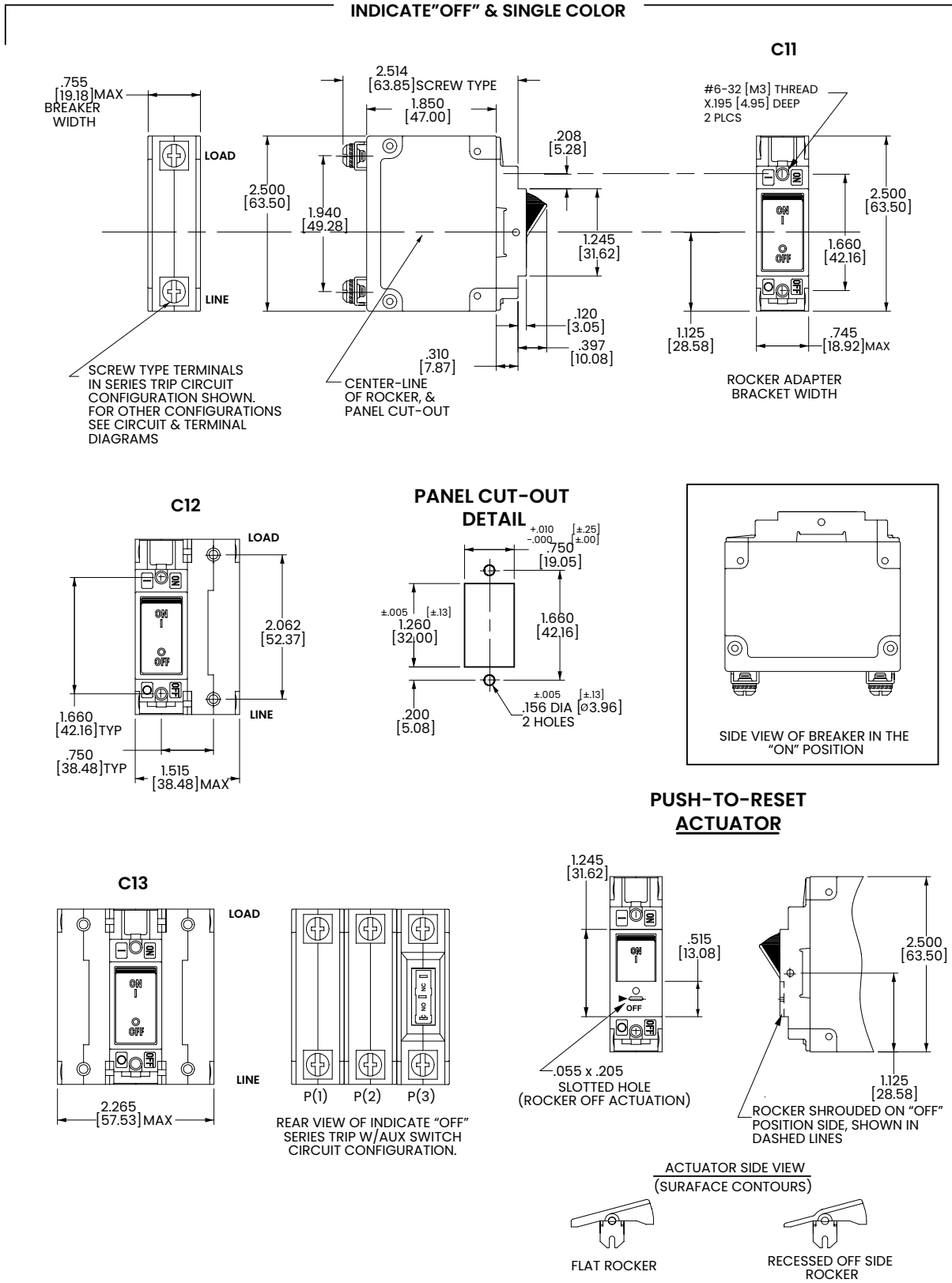

- Notes:
- 1 For pole orientation with horizontal legend, rotate front view clockwise 90°.
 - 2 Tolerance ±.020 [.51] unless otherwise specified.

CX-Series

Hydraulic-Magnetic Circuit Breaker

PRODUCT WEBPAGE

request sample, configure part, watch video



High Amperage and DC Voltage Circuit Breaker Disconnect for UL 489B Applications

The CX-Series hydraulic-magnetic circuit breakers employ a patented magnetic flux boosting terminal configuration to offer rapid cooling and superior performance for high amperage and high DC voltage applications. Compact in size, the CX-Series is available as a one pole breaker rated up to 125 amps, as a two to four pole breaker rated up to 115 amps, and as a disconnect option with additional amperage and pole configuration options. Maximum voltage capacity of 600VDC and 10,000 amps max IC.

1-5 125 600 Suited for 380VDC
 Poles Amps Max VDC Max Applications

Typical Applications

- Datacom, PDU and UPS Systems
- Renewable Energy
- Charging Stations
- Mission Critical Equipment
- Power Supplies and Convertors
- Motor Controllers
- Smart Grids

Design Features

HYDRAULIC/MAGNETIC SENSING COIL

UPPER ARC RUNNER
Aids in motivating arc off of movable contact and into arc chamber

MAGNETS

ARC SPLITTER RETAINER
with integrated pressurizing walls

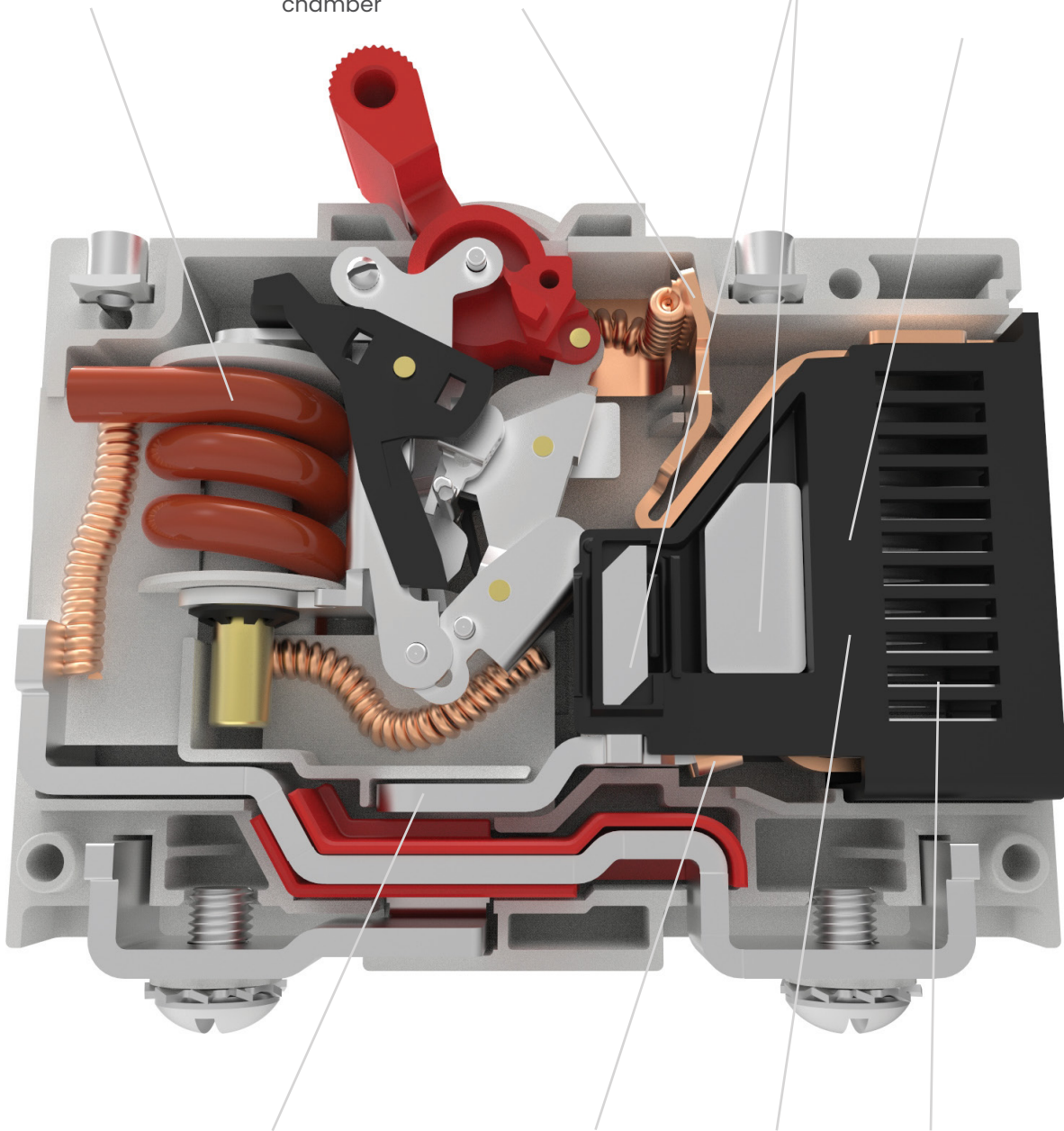

PATENTED MAGNETIC FLUX BOOSTING TERMINAL CONFIGURATION
Design enhances motivation of arc into arc chamber

LOWER ARC RUNNER
Aids in motivating arc off of stationary contact and into arc chamber

LARGE ARC GAP
To generate high arc voltages

(12) ARC DEIONIZING SPLITTER PLATES

Tech Specs

Electrical

Maximum Voltage	600 VDC
Overload	50 operations at 600% of rated current for UL489, and at 150% of rated current for UL1077.

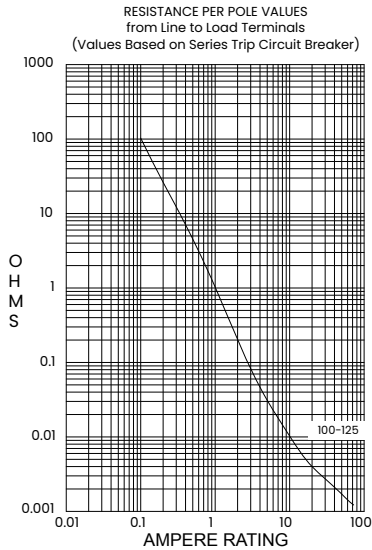

CURRENT (AMPS)	TOLERANCE (%)
0.10 - 5.0	15
5.1 - 20.0	25
20.1 - 50.0	35

Physical

Number of Poles	1- 2 poles, + Auxiliary Switch Pole.
Termination	10-32 or M5 Screw Terminals
Terminals	1/4-20 or M6 Threaded Stud
Termination Barrier	Standard with multi-pole constructions
Mounting	Threaded insert: #6-32 UNC-2B, or M3X0.5-6H B ISO (2 per pole)
Actuator	Handle, 1 per pole.
Internal Circuit Configuration	Series Trip
Materials	Housing - Glass filled Polyester Handle - Glass filled Polyester Line/Load Terminals - Copper Alloy.~150 Grams (~5.3 Ounces).
Weight	~150 Grams (~5.3 Ounces).
Standard Color	Housing - Gray. Handle - White, Black, Red, Green, Blue, Yellow, Gray,

Environmental

Designed and tested in accordance with requirements of specification MIL-PRF-55629 & MIL-STD-202 as follows:

Shock	Withstands 100 Gs, 6ms saw tooth while carrying rated current per MILPRF-55629 and MIL-STD-202G, Method 213G, Test Condition "I". Instantaneous and ultra short curves tested at 90% of rated current
Vibration	Withstands 0.060" excursion from 10-55 Hz & 10 Gs 55-500 Hz, at rated current per MIL-PRF-55629 and MILSTD-202G, Method 204D, Test Cond. A. Instantaneous & ultrashort curves tested at 90% of rated current.
Moisture Resistance	MIL-PRF-55629 and MIL-STD-202G, Method 106G, i.e., Ten 24-hour cycles at +25°C to +65°C, 80-98% RH.
Salt Spray	Method 101, Condition A (90-95% RH at 5% NaCl Solution, 96 hrs).
Thermal Shock	MIL-PRF-55629 and MIL-STD-202G, Method 107G, Condition A (5-cycles at -55°C to +25°C to +85°C to +25°C).
Operating Temperature	-40°C to +85°C.

Mechanical

Endurance	Max 10,000 ON-OFF operations @ 6 per minute; 6000 with rated current & voltage, and 4,000 cycles mechanical.
Trip Free	Trips on overload even when actuator is forcibly held in the "On" position.
Trip Indication	The operating handle moves positively to the "Off" position when an overload causes the breaker to trip.

Tech Specs

Tables

Table A: Lists UL Listed (UL489) configuration and performance capabilities as a Molded Case Circuit Breaker

UL489 Listed Branch Circuit Breakers					
Circuit Configuration	Voltage		Max Current Rating (Amps)	Interrupting Capacity (Amps)	Poles
	Max Rating	Frequency			
Series	250	DC	15	5,000	1
	250 / 500			10,000	2
	410 / 205		50		

Table B: Lists UL Recognized configurations and performance capabilities as a Component Supplementary Protector

UL1077 Component Supplementary Protector						
Circuit Configuration	Voltage		Max Current Rating (Amps)	Interrupting Capacity (Amps)	Poles	Application Code
	Max Rating	Frequency				
Series	300	DC	1 - 75	5,000	1	TC1, OL0, U3
	300		76 - 125	3,000		
	440		1 - 30	10,000	2	
			31 - 63	5,000		
	600		1 - 75	5,000	2	
			78 - 115	3,000		
Switch Only ¹	600		1 - 115	-	2 or 3	-

Notes

¹ Requires inclusion of a relay trip voltage coil

Table C: Lists UL Listed (UL489B) configuration and performance capabilities as a Molded Case Switch

UL489B Listed Photovoltaic Molded Case Switch						
Circuit Configuration	Voltage			Current Rating (Amps)	Interrupting Capacity (Amps)	Application Code
	Max Rating	Frequency	Poles			
Series	600	DC	2 ¹	50 - 100	600	May have a third pole that is a voltage pole
			4 ²	110 - 175		May have a fifth pole that is a voltage trip pole

Notes

¹ Two poles in series.

² Two poles in series in parallel with 2 poles in series.

Table D: TUV Certified Configuration to IEC / EN 60947-2. Low Voltage Switch gear and Control gear - Circuit Breakers

TUV IEC/EN 60947-2 Low Voltage Switch Gear & Control Gear / Circuit Breaker					
Circuit Configuration	Voltage			Current Rating (Amps)	Interrupting Capacity ICS / ICU (Amps)
	Max Rating	Frequency	Poles		
Series	440	DC	2	1 - 63	4,000

Time Delay Specs

To view all hydraulic-magnetic circuit breaker time delay values, please visit www.carlingtech.com/sites/default/files/documents/Carling-HM-CB-Time-Delays.pdf

Ordering Scheme UL 489 Listed

Sample Part Number C X 1 - B 0 - 14 - 615 - 2 2 A - 12 G

Selection 1 2 3 4 5 6 7 8 9 10 11 12

1. SERIES

C

2. ACTUATOR

X Handle, one per pole

3. POLES

1 One
2 Two

4. CIRCUIT

B Series Trip (current)

5 AUXILIARY/ALARM SWITCH

0 Without Aux Switch

6. FREQUENCY & DELAY

11 DC Ultra Short
12 DC Short
14 DC Medium
16 DC Long

7. CURRENT RATING (AMPERES)

CODE	AMPERES				
220	0.20	295	0.95	460	6.00
225	0.25	410	1.00	465	6.50
230	0.30	512	1.25	470	7.00
235	0.35	415	1.50	475	7.50
240	0.40	517	1.75	480	8.00
245	0.45	420	2.00	485	8.50
250	0.50	522	2.25	490	9.00
255	0.55	425	2.50	495	9.50
260	0.60	527	2.75	610	10.00
265	0.65	430	3.00	710	10.50
270	0.70	435	3.50	611	11.00
275	0.75	440	4.00	711	11.50
280	0.80	445	4.50	612	12.00
285	0.85	450	5.00	712	12.50
290	0.90	455	5.50	613	13.00
				614	14.00
				615	15.00
				616	16.00
				617	17.00
				618	18.00
				620	20.00
				622	22.00
				624	24.00
				625	25.00
				630	30.00
				635	35.00
				640	40.00
				645	45.00
				650	50.00

8. TERMINAL

2 Screw Terminal, 10-32
3 Stud, 1/4-20
5 Screw Terminal, M5
6 Stud, M6

9 ACTUATOR COLOR & LEGEND

Actuator Color	I-O	ON-OFF	Dual	Legend Color
White	A	B	1	Black
Black	C	D	2	White
Red	F	G	3	White
Green	H	J	4	White
Blue	K	L	5	White
Yellow	M	N	6	Black
Gray	P	Q	7	Black
Orange	R	S	8	Black

10. MOUNTING INSERTS

A 6-32 Thread
B M3 Thread

11. MAXIMUM APPLICATION RATING

12 250 VDC
13 250/500 VDC ¹
15 205/410 VDC

12. AGENCY APPROVAL

A Without Approvals
G UL 489 Listed
S UL 489 Listed, TUV to IEC60947-2 ¹

Notes:
¹ Only Available with 250/500 VDC up to 15 amps.

[Configure Complete Part Number >](#)

[Browse Standard Parts >](#)

Ordering Scheme UL 489B Listed

Sample Part Number **C X 2 - S 0 - 03 - 810 - 3 2 A - 06 14**

Selection 1 2 3 4 5 6 7 8 9 10 11 12

1. SERIES

C

2. ACTUATOR

X Handle, one per pole

3. POLES ^{1,2}

2 Two
3 Three
4 Four
5 Five

4. CIRCUIT

S Switch Only

5. RELAY TRIP VOLTAGE COIL RATING ^{1,2}

0 Without Relay Trip Voltage Coil
A 12 VDC
B 24 VDC
C 32 VDC
D 48 VDC

6. FREQUENCY & DELAY

03 DC Switch Only

7. CURRENT RATING (AMPERES) ^{1,3}

2-Pole Section
810 50A - 100A

4-Pole Section
917 110A - 175A

8. TERMINAL ^{4,5}

3 Stud, 1/4-20
6 Stud, M6
A Stud, 1/4-20, with 10-32 Screw Terminals on Voltage Pole
B Stud, M6, with M5 Screw Terminals on Voltage Pole

9 ACTUATOR COLOR & LEGEND

Actuator Color	I-O	ON-OFF	Dual	Legend Color
White	A	B	1	Black
Black	C	D	2	White
Red	F	G	3	White
Green	H	J	4	White
Blue	K	L	5	White
Yellow	M	N	6	Black
Gray	P	Q	7	Black
Orange	R	S	8	Black

10. MOUNTING INSERTS

A 6-32 Thread
B M3 Thread

11. MAXIMUM APPLICATION RATING

06 600 VDC

12. AGENCY APPROVAL

A Without Approvals
14 UL489B Listed

Notes:

- 2 Pole Unit is required for ratings between 50A - 100A.
4 Pole Unit is required for ratings between 110A - 175A.
- A Relay Trip Voltage Coil Pole may be added to either the 2 or 4 Pole construction.
The addition of this extra pole dictates a change in the designation for the number of poles in selection 3.
- For Current Ratings between 50A - 100A select current code 810 (100A).
For Current Ratings between 110A - 175A select current code 917 (175A).
- Voltage Pole must have screw terminals.
Switch Pole must have stud terminals.
- On 3 Pole Unit, Voltage Pole to be located at P1 as standard.
On 5 Pole Unit, Voltage Pole to be located at P3 as standard.

[Configure Complete Part Number >](#)

[Browse Standard Parts >](#)

Ordering Scheme UL 1077 Recognized

Sample Part Number

C X 1 - B 0 - 14 - 620 - 2 2 A - 10 C

Selection 1 2 3 4 5 6 7 8 9 10 11 12

1. SERIES

C

2. ACTUATOR

X Handle, one per pole

3. POLES ⁷

1 One 3 Three
2 Two 4 Four¹⁰

4. CIRCUIT

A Switch Only (no coil)^{1, 9}
B Series Trip (current)
G Relay Trip (voltage)^{1, 2, 3, 9}

5. AUXILIARY SWITCH

0 Without Aux Switch

6. FREQUENCY & DELAY

03 DC 50/60Hz, Switch Only
10 DC Instantaneous
11 DC Ultra Short
12 DC Short
14 DC Medium
16 DC Long

7. CURRENT RATING (AMPERES)

CODE	AMPERES				
220	0.200	415	1.500	490	9.000
225	0.250	517	1.750	495	9.500
230	0.300	420	2.000	610	10.000
235	0.350	522	2.250	710	10.500
240	0.400	425	2.500	611	11.000
245	0.450	527	2.750	711	11.500
250	0.500	430	3.000	612	12.000
255	0.550	435	3.500	712	12.500
260	0.600	440	4.000	613	13.000
265	0.650	445	4.500	614	14.000
270	0.700	450	5.000	615	15.000
275	0.750	455	5.500	616	16.000
280	0.800	460	6.000	617	17.000
285	0.850	465	6.500	618	18.000
290	0.900	470	7.000	620	20.000
295	0.950	475	7.500	622	22.000
410	1.000	480	8.000	624	24.000
512	1.250	485	8.500	625	25.000

8. TERMINAL ⁸

2 Screw, 10-32
3 Stud, 1/4-20
5 Screw, M5
6 Stud, M6

9 ACTUATOR COLOR & LEGEND

Actuator Color	I-O	ON-OFF	Dual	Legend Color
White	A	B	1	Black
Black	C	D	2	White
Red	F	G	3	White
Green	H	J	4	White
Blue	K	L	5	White
Yellow	M	N	6	Black
Gray	P	Q	7	Black
Orange	R	S	8	Black

10. MOUNTING INSERTS

A 6-32 Thread
B M3 Thread

11. MAXIMUM APPLICATION RATING

10 300VDC
11 440 VDC without factory installed terminal bus⁴
14 440VDC with factory installed terminal bus⁴
06 600VDC⁵
18 220/440VDC¹¹

12. AGENCY APPROVAL

A Without Approvals
C UL 1077 Recognized
W UL 1077 Recognized & TUV Certified IEC/ EN 60947-2⁹

Notes:

- 1 Only available when tied to a protected pole. Requires special part number consult factory for details
- 2 Voltage trip circuit coil not rated for continuous duty - use instantaneous delay code 10
- 3 Contacts Rated for 20A @ 80 VDC
- 4 440 VDC Rating available in two different wiring configurations.
- 5 600 VDC only available with factory installed terminal bus.
- 6 Single pole units available up to 125A, multi pole units limited to 115A Max.
- 7 3 Pole units must include one Auxiliary switch pole (circuit code A or G) - Requires Special Part Number. Unless breaker is rated 220/440 VDC (Voltage Code 18) in which case Circuit Code B is required.
- 8 Screw Terminals are limited to 50A max.
- 9 Agency approval code W only available with 440 VDC or 220/440 VDC rating and circuit code B.
- 10 4 Pole 600 VDC units only available up to 75A Max.
- 11 3 Pole 220/440 VDC units only available in one specific wiring configuration. See dimensional specifications pages for more details

[Configure Complete Part Number >](#)

[Browse Standard Parts >](#)

Dimensional Specs UL 489 Listed

inches [millimeters]

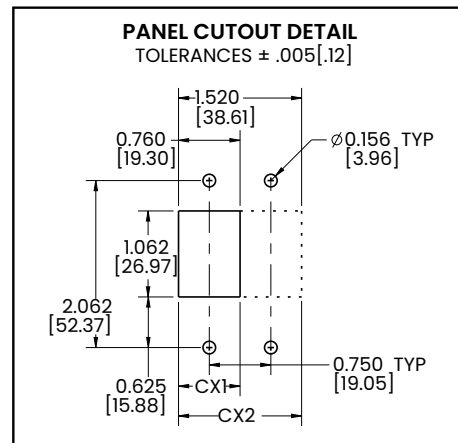
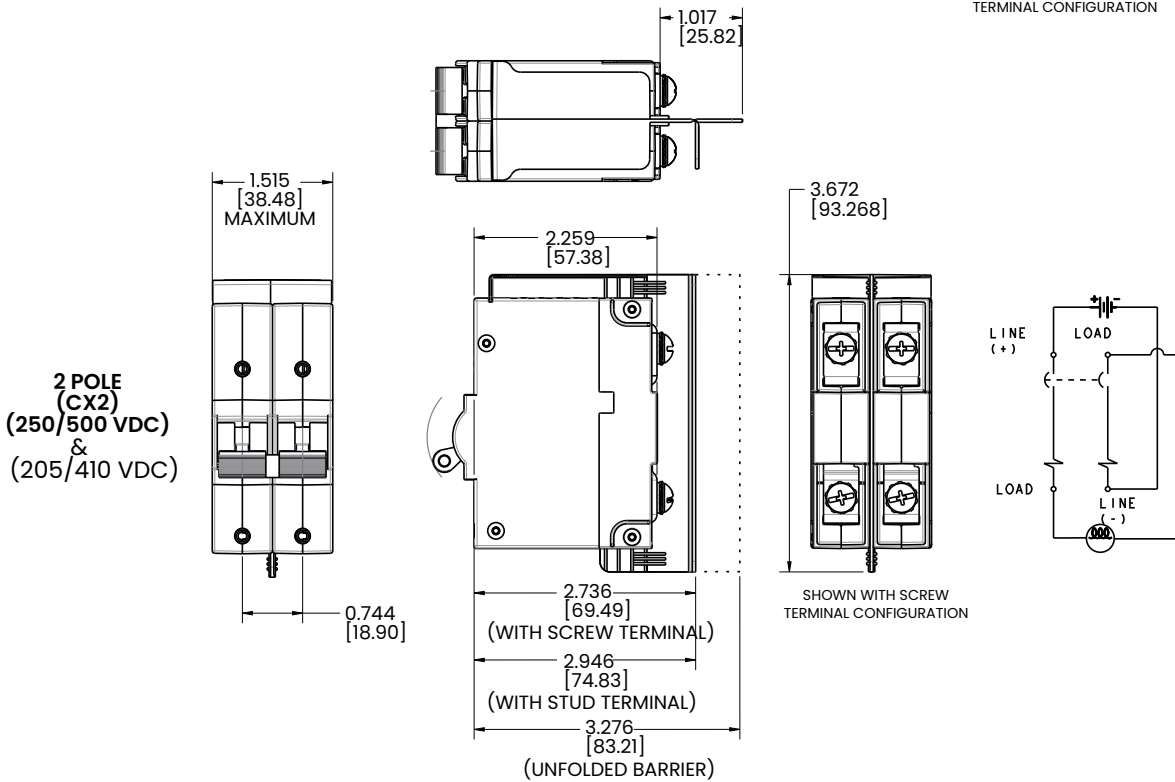
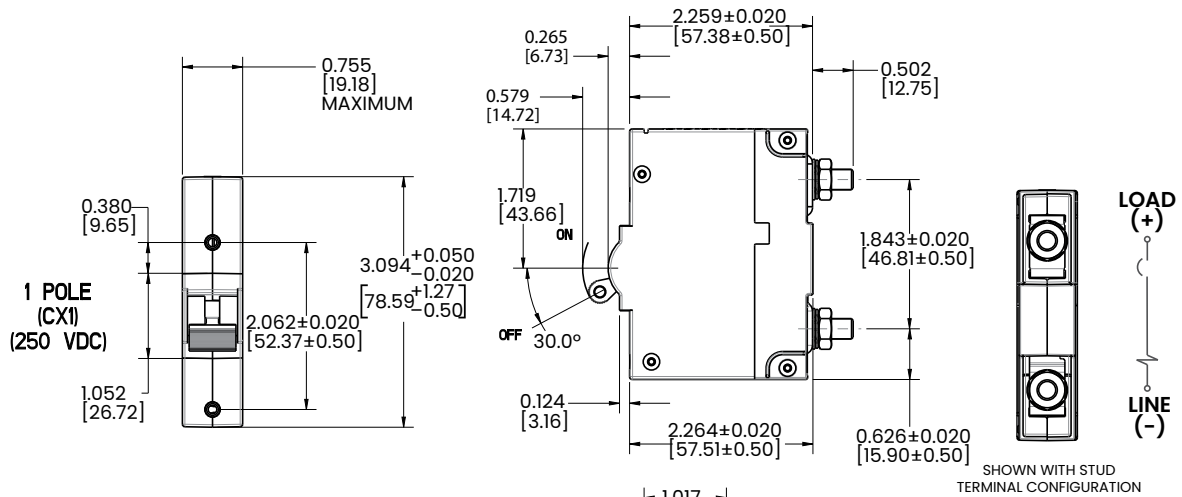

Notes:
1 600V Rating requires minimum of 2 protected poles

Dimensional Specs UL 489B Listed

inches [millimeters]

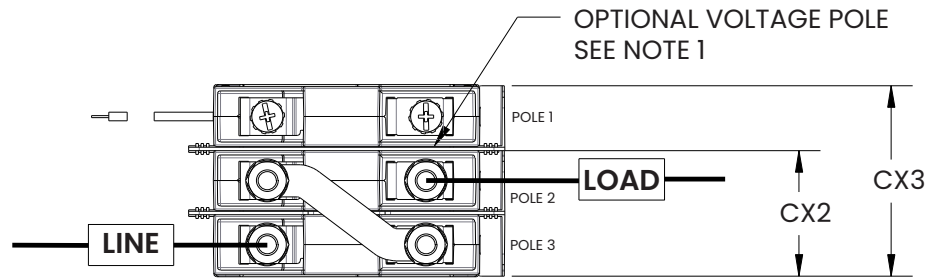
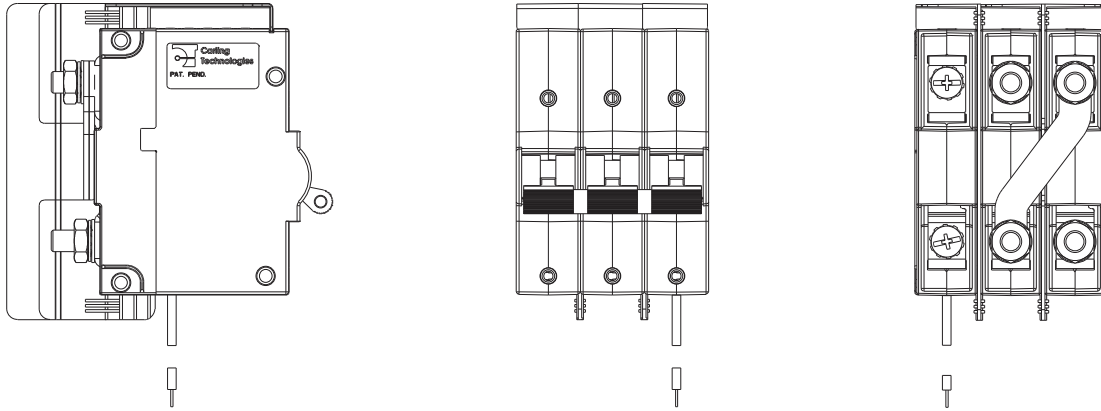

CX3-2 POLE SWITCH (CX2) SHOWN
WITH OPTIONAL VOLTAGE POLE
50A-100A DEVICE, 600VDC

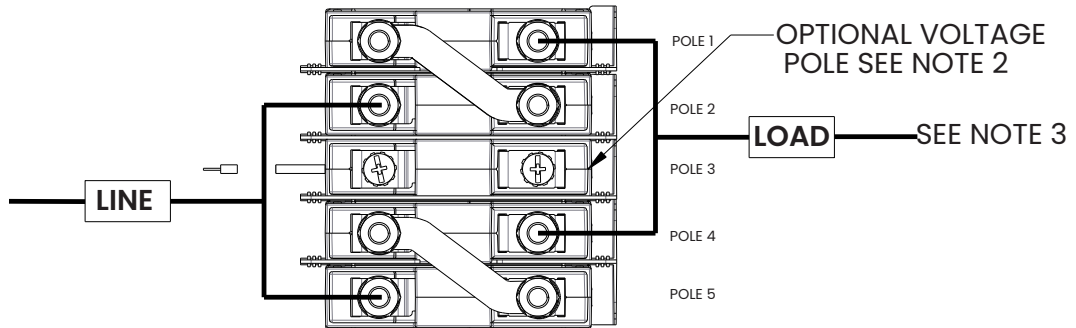

CX5-4 POLE SWITCH (CX4) SHOWN
WITH OPTIONAL VOLTAGE POLE
101A-175A DEVICE, 600VDC

Notes:

- 1 3 pole configuration supplied with voltage coil on pole 1. Optional location pole 3. Consult factory.
- 2 5 pole configuration supplied with voltage coil in center pole. (Pole 3)
- 3 Line & Load connections requires bus connection as shown.
Minimum cross section .127 in² (81.94 mm²)

Dimensional Specs UL 1077 Recognized

inches [millimeters]

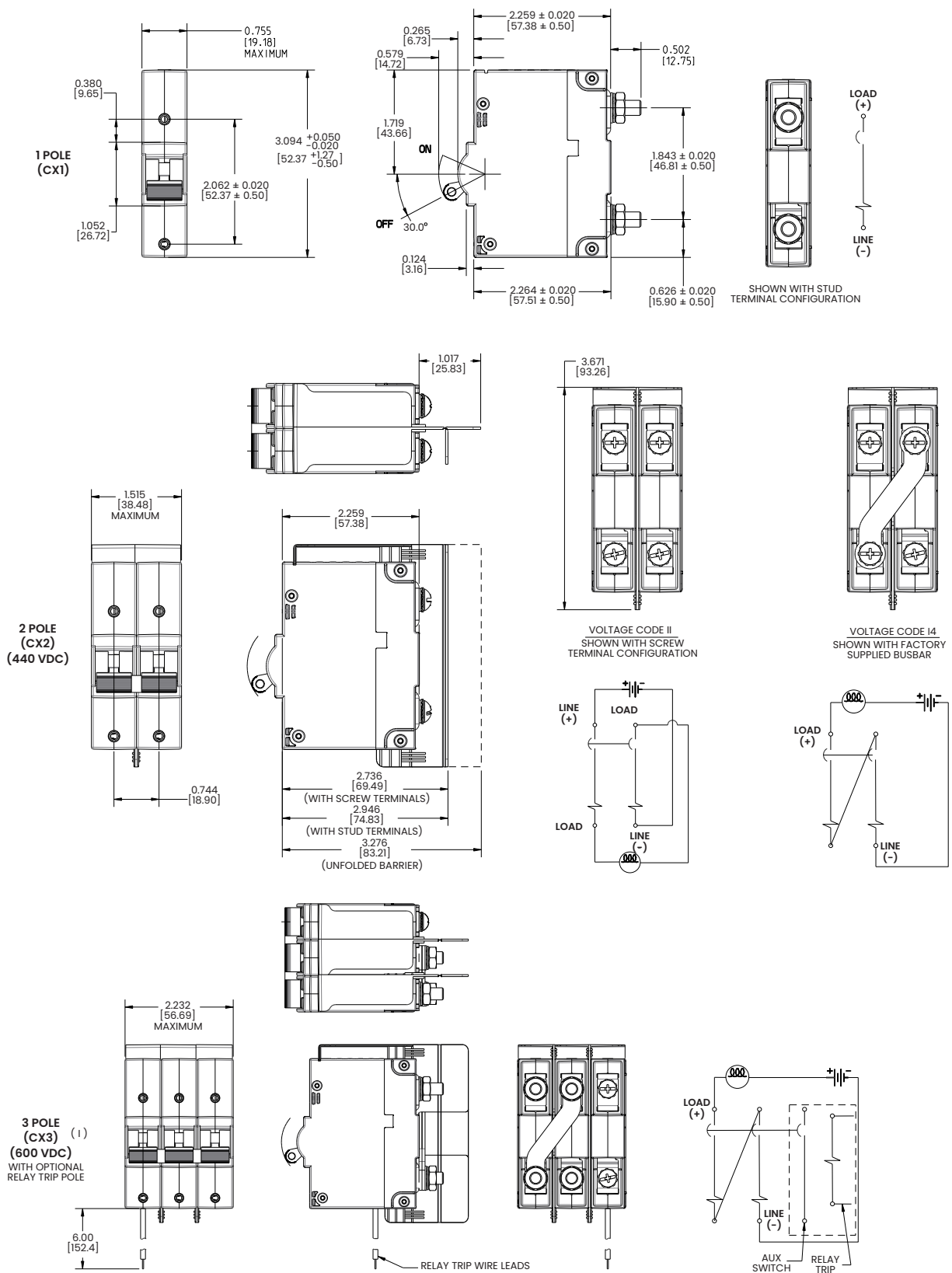

Notes:
 1 600V Rating requires minimum of 2 protected poles

Dimensional Specs UL 1077 Recognized

inches [millimeters]

**3 POLE
(CX3)
(220/440 VDC)**

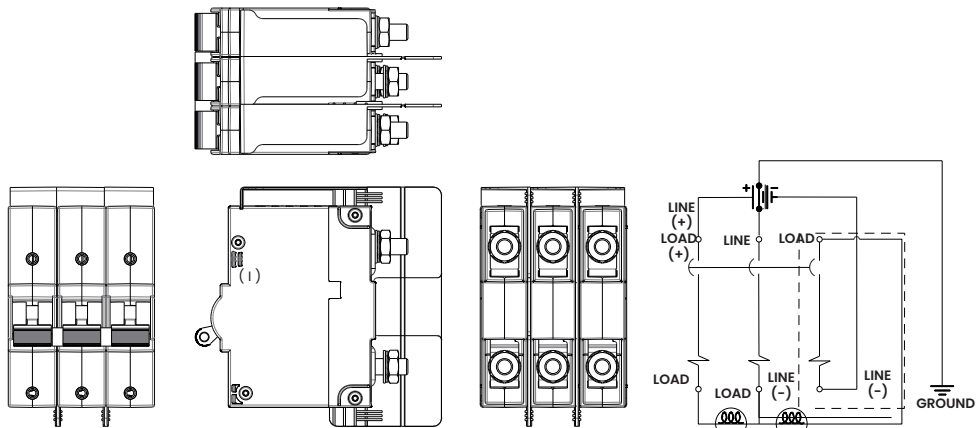

**4 POLE
(CX4) (1,2)
(600 VDC)**

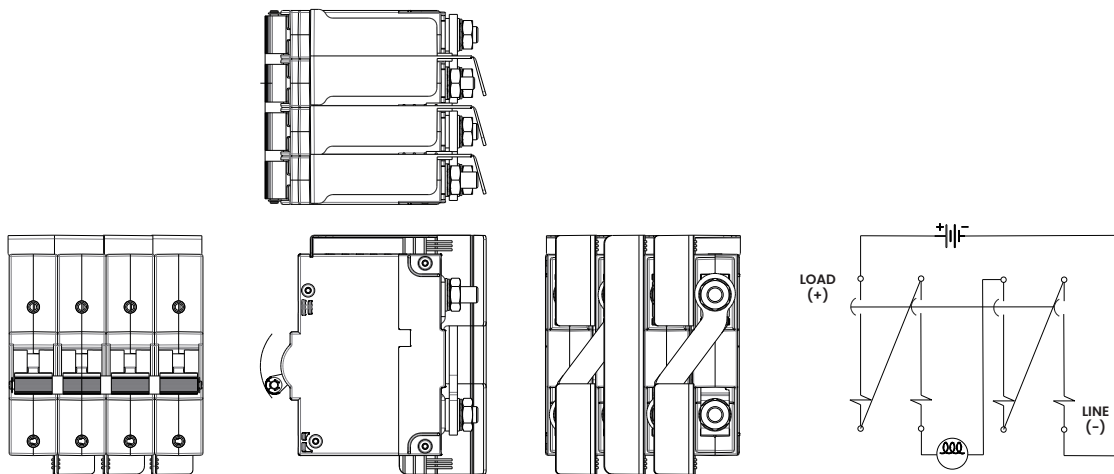

(2) FOUR POLE UNIT AVAILABLE UP TO 75A MAXIMUM

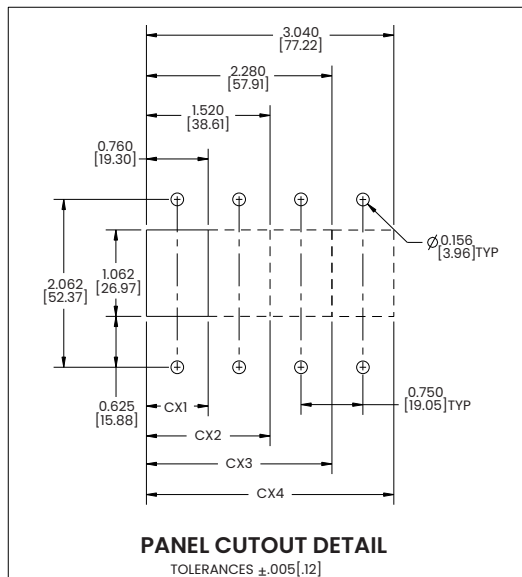

Notes:

- 1 600V Rating requires minimum of 2 protected poles

D-Series

Hydraulic-Magnetic Circuit Breaker

PRODUCT WEBPAGE

request sample, configure part, watch video

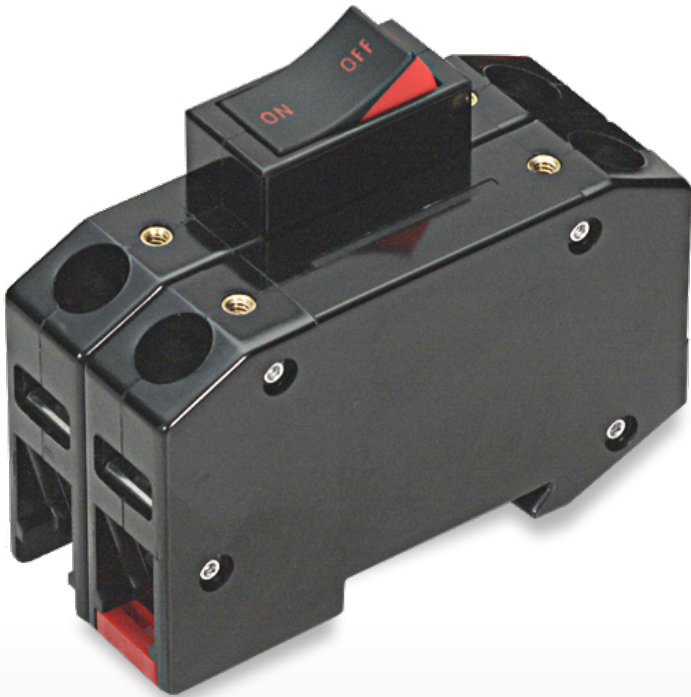
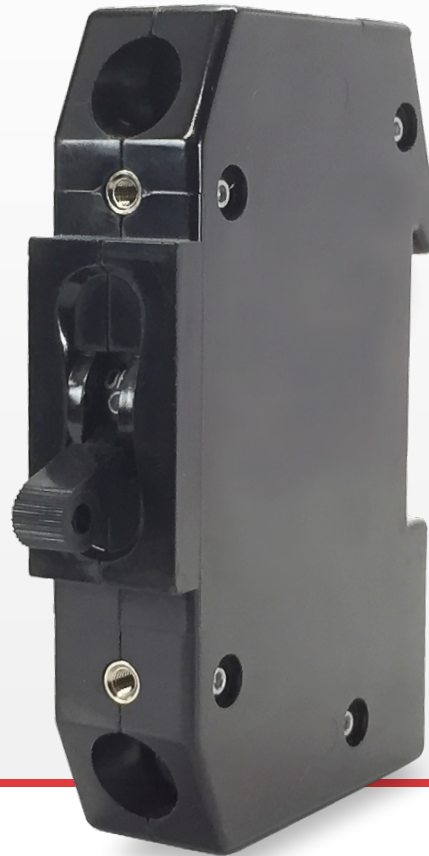

DIN Rail Mounted Circuit Breaker

The D-Series hydraulic-magnetic circuit breakers feature simple snap on back panel DIN rail mounting for easy assembly and removal. Added safety features round out this thoughtful breaker design with recessed wire ready terminals that are both touch proof and shock resistant. D-Series breakers are available as a one to four pole breaker, rated up to 50 amps, 480Y/277VAC or 80VDC and with a max IC of 5,000 amps.

1-4	0.02-50	80	480Y
Poles	Amps	VDC Max	VAC Max

Typical Applications

- Industrial Controls
- Renewable Energy

Tech Specs

Electrical

Maximum Voltage	AC, 480Y VAC (See Table A), 50/60 Hz, 80VDC
Standard Current Coils	0.100, 0.250, 0.500, 0.750, 1.00, 2.50, 5.00, 7.50, 10.0, 15.0, 20.0, 25.0, 30.0, 35.0, 40.0 & 50.0. Other ratings available - consult factory.
Standard Voltage Coils	DC - 6V, 12V; AC - 120V, other ratings available, see ordering scheme.
Insulation Resistance	Minimum of 100 Megohms at 500 VDC.
Dielectric Strength	UL, CSA: 1960 V 50/60 Hz for one minute between all electrically isolated terminals. D-Series circuit breakers comply with the 8mm spacing and 3750V 50/60 Hz dielectric requirements from hazardous voltage to operator accessible surfaces and between adjacent poles per Publications EN 60950 and VDE 0805.
Resistance, Impedance	Values from Line to Load Terminal based on Series Trip Circuit Breaker

Mechanical

Endurance	10,000 ON-OFF operations @ 6 per minute; with rated current & voltage.
Trip Free	All D-Series circuit breakers will trip on overload, even when actuator is forcibly held in the ON position.
Trip Indication	The operating actuator moves positively to the OFF position when an overload causes the breaker to trip.

Physical

Number of Poles	Rocker Type: 1-3; Handle Type: 1-4
Internal Circuit Config.	Switch Only and Series Trip with current or voltage trip coils.
Weight	Approximately 128 grams/pole (Approximately 4.57 ounces/pole)
Standard Colors	Housing - Black; Actuator - See Ordering Scheme.
Mounting	Mounts on a standard 35mm Symmetrical DIN Rail (35 x 7.5 or 35 x 15mm per DIN EN5002).

RESISTANCE PER POLE VALUES
from Line to Load Terminals
(Values Based on Series Trip Circuit Breaker)

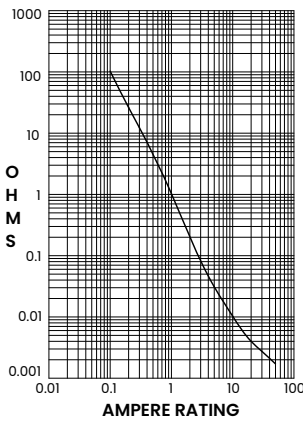

CURRENT (AMPS)	TOLERANCE (%)
0.10 - 5.0	15
5.1 - 20.0	25
20.1 - 50.0	35

Pulse Tolerance Curves

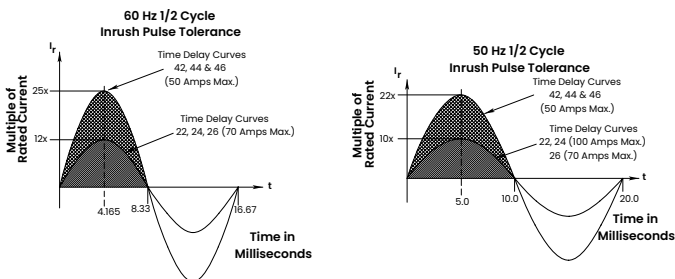

Environmental

Designed and tested in accordance with requirements of specification MIL-PRF-55629 & MIL-STD-202 as follows:

Shock	Withstands 100 Gs, 6ms, sawtooth while carrying rated current per Method 213, Test Condition "I". Instantaneous and ultra-short curves tested @ 90% of rated current.
Vibration	Withstands 0.060" excursion from 10-55 Hz, and 10 Gs 55-500 Hz, at rated current per Method 204C, Test Condition A. Instantaneous and ultra-short curves tested at 90% of rated current.
Moisture Resistance	Method 106D, i.e., ten 24-hour cycles @ + 25°C to +65°C, 80- 98% RH.
Salt Spray	Method 101, Condition A (90-95% RH @ 5% NaCl Solution, 96 hrs).
Thermal Shock	Method 107D, Condition A (Five cycles @ -55°C to +25°C to +85°C to +25°C).
Operating Temperature	-40° C to +85° C

Tech Specs

Tables

Table A: Lists UL Recognized, CSA Accepted and VDE Certified configurations and performance capabilities as a Component Supplementary Protector.

Component Supplementary Protectors										
Circuit Configuration	Voltage			Current Rating	Short Circuit Capacity (Amps)				Application Codes	
	Max Rating	Frequency	Phase ¹		UL/CSA		VDE		UL	CSA
				Full Load Amps	with Backup Fuse	without Backup Fuse	(Inc) with Backup Fuse	(Inc) without Backup Fuse		
Series	65	DC	---	0.02 - 50	---	5,000	5,000	1,500	TC1, 2, OL1, UI	TC1, 2, OL1, UI
	80									
	125 / 250	50 / 60	1		3,000	---	---			
	250		1 & 3		5,000 ²	---	---	---		
	277		1							
480 V ³	1 & 3	---	---	TC1, 2, OL1, C1	TC1, 2, OL1, C1					
Switch Only	65	DC	---	0.02 - 50	---	---	---	---	---	---
	250									
	277	50 / 60	1							
	480 V ³	1 & 3	0.02 - 30							

Notes:

- DC and 1 Phase 277 V ratings are 1 or 2 poles breaking. Three phase ratings are 3 poles breaking.
- Requires branch circuit backup with a UL LISTED Type K5 or RK5 fuse rated 15A minimum and no more than 4 times full load amps not to exceed 150 A for 250V rating and 125 A for 277 and 480 V ratings.
- UL recognition and CSA Acceptance at 480 volts refers to 3 and 4 pole versions, used only in a 3 phase WYE connected circuit or 2 pole versions connected with 2 poles breaking 1 phase and backed up with series fusing per note 2

Agency Approvals

UL 1077	Component Recognition Program as Protectors, Supplementary (Guide QVNU2, File E75596)
UL 508	Switches, Industrial Control (Guide NRNT2, File E148683)
CSA Accepted	Component Supplementary Protector under Class 3215 30, File 047848 0 000 CSA Standard C22.2 No. 235
VDE Certified	EN60934, VDE 0642 under File No. 10537

Time Delay Specs

To view all hydraulic-magnetic circuit breaker time delay values, please visit www.carlingtech.com/sites/default/files/documents/Carling-HM-CB-Time-Delays.pdf

Ordering Scheme

Handle & Rocker

Sample Part Number D A 3 - B0 - 10 - 450 - 1 2 1 - C

Selection 1 2 3 4 5 6 7 8 9 10

1. SERIES

D D-Series

2. ACTUATOR ¹

Handle ²

A Handle, one per pole

B Handle, one per multipole unit

Visi-Rocker ³

C Indicate ON, vertical legend

D Indicate ON, horizontal legend

E Indicate ON, no legend (VDE approval not available with no legend)

F Indicate OFF, vertical legend

G Indicate OFF, horizontal legend

H Indicate OFF, no legend (VDE approval not available with no legend)

Single Color Rocker ³

J Vertical legend

K Horizontal legend

L No legend (VDE approval not available with no legend)

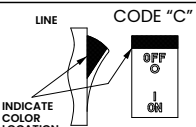
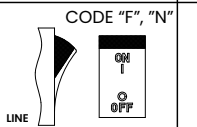
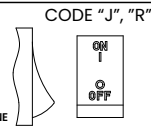
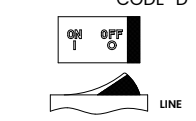
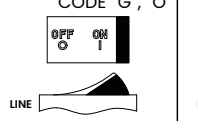
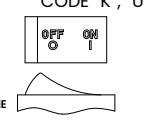
ROCKER STYLE DESCRIPTIONS			
	INDICATE "ON"	INDICATE "OFF"	SINGLE COLOR
VERTICAL STYLE	 <p>LINE CODE "C"</p> <p>INDICATE COLOR LOCATION</p>	 <p>LINE CODE "F", "N"</p>	 <p>LINE CODE "J", "R"</p>
	 <p>CODE "D"</p>	 <p>CODE "G", "O"</p>	 <p>LINE CODE "K", "U"</p>

3. POLES ²

1 One

2 Two

3 Three

4 Four

4. CIRCUIT

A0 Switch Only (No Coil) ⁴

B0 Series Trip (Current)

C0 Series Trip (Voltage)

5. FREQUENCY & DELAY

03 DC 50/60Hz, Switch Only

10 ⁵ DC Instantaneous

11 DC Ultra Short

12 DC Short

14 DC Medium

16 DC Long

20 ⁵ 50/60Hz Instantaneous

21 50/60Hz Ultra Short

22 50/60Hz Short

24 50/60Hz Medium

26 50/60Hz Long

32 DC, 50/60Hz Short

34 DC, 50/60Hz Medium

36 DC, 50/60Hz Long

42 ⁶ 50/60Hz Short, High-inrush

44 ⁶ 50/60Hz Medium, High-inrush

46 ⁶ 50/60Hz Long, High-inrush

52 ⁶ DC, Short, High-inrush

54 ⁶ DC, Medium, High-inrush

56 ⁶ DC, Long, High-inrush

Notes:

1 Handle breakers available up to four poles. Rocker breakers available up to three poles.

2 Actuator Code:

A: Multi-pole units factory assembled with common handle tie.

B: Handle location as viewed from front of breaker:

2 pole - left pole

3 pole - center pole

4 pole - two handles at center poles

3 Multipole rocker breakers have one rocker per breaker, as viewed from the front of the panel. Two pole - left pole. Three pole - center pole

4 ≤ 30A, select Current Rating code 630. 31-50A, select Current Rating code 650.

5 Voltage coil only available with delay codes 10 & 20.

6 Available to 50A max with circuit code B0 only.

7 Color shown is visi and legend with remainder of rocker black.

8 ≥ 300V. Three pole breaker 3Ø or 2 pole breaker 1Ø, UL/CSA limited to 30 FLA max.

9 VDE Approval requires Dual (I-O, ON-OFF) or I-O markings

6. CURRENT RATING (AMPERES) ⁹

CODE AMPERES

020	0.020	275	0.750	450	5.000	616	16.000
025	0.025	280	0.800	455	5.500	617	17.000
030	0.030	285	0.850	460	6.000	618	18.000
050	0.050	410	1.000	465	6.500	619	19.000
075	0.075	512	1.250	470	7.000	620	20.000
080	0.080	413	1.300	572	7.250	621	21.000
085	0.085	414	1.400	475	7.500	622	22.000
210	0.100	415	1.500	480	8.000	623	23.000
215	0.150	517	1.750	485	8.500	624	24.000
220	0.200	420	2.000	490	9.000	625	25.000
225	0.250	522	2.250	495	9.500	626	26.000
230	0.300	425	2.500	610	10.000	627	27.000
235	0.350	527	2.750	710	10.500	628	28.000
240	0.400	430	3.000	611	11.000	629	29.000
245	0.450	532	3.250	711	11.500	630	30.000
250	0.500	435	3.500	612	12.000	632	32.000
255	0.550	436	3.600	712	12.500	635	35.000
260	0.600	440	4.000	613	13.000	640	40.000
265	0.650	445	4.500	614	14.000	645	45.000
270	0.700	547	4.750	615	15.000	650	50.000

OR VOLTAGE COIL (NORMAL RATED VOLTAGE)

CODE AMPERES

A06	6 DC, 5 DC	A48	48 DC, 40 DC	J24	24 AC, 20 AC
A12	12 DC, 10 DC	A65	65 DC, 55 DC	J48	48 AC, 40 AC
A18	18 DC, 15 DC	J06	6 AC, 5 AC	K20	120 AC, 65 AC
A24	24 DC, 20 DC	J12	12 AC, 10 AC	L40	240 AC, 130 AC
A32	32 DC, 25 DC	J18	18 AC, 15 AC		

7. TERMINAL

- #10 Screw & Pressure Plate for Direct Wire Connection
- #10 Screw without Pressure Plate

8. ACTUATOR COLOR & LEGEND

Actuator or

Visi-Color Marking:

Color:	I-O	ON-OFF	Dual/None	Marking Color: Single Color	Rocker/Handle	Visi-Rocker ⁷
White	A	B	1	Black	White	White
Black	C	D	2	White	n/a	n/a
Red	F	G	3	White	Red	Red
Green	H	J	4	White	Green	Green
Blue	K	L	5	White	Blue	Blue
Yellow	M	N	6	Black	Yellow	Yellow
Gray	P	Q	7	Black	Gray	Gray
Orange	R	S	8	Black	Orange	Orange

9. MOUNTING / VOLTAGE

	MOUNTING STYLE	VOLTAGE
1	Threaded Insert	
1	6-32 x 0.195 inches	< 300
C ⁸	6-32 X 0.195 inches	≥ 300
2	ISO M3 x 5mm	< 300
D ⁸	ISO M3 x 5mm	≥ 300

10. AGENCY APPROVAL

- C UL Recognized & CSA Accepted
- D ⁹ VDE Certified, UL Recognized & CSA Accepted

Circuit & Terminal Diagram

inches [millimeters]

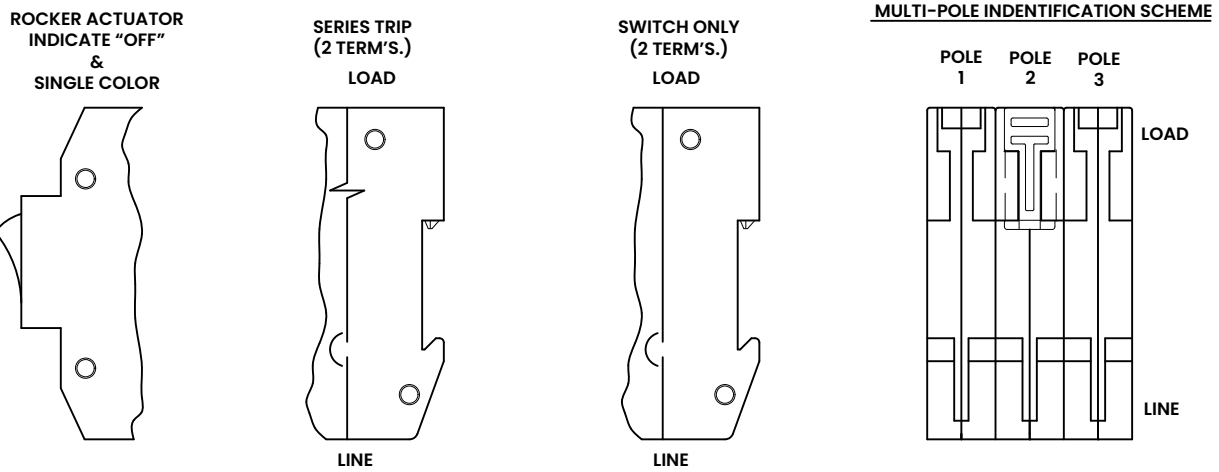
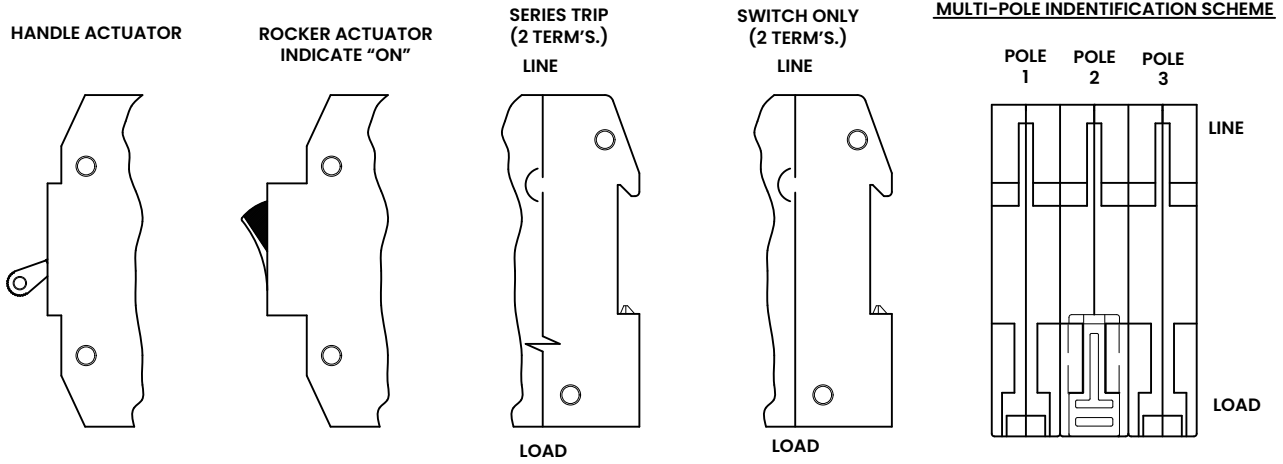

(HANDLE ACTUATOR SHOWN)

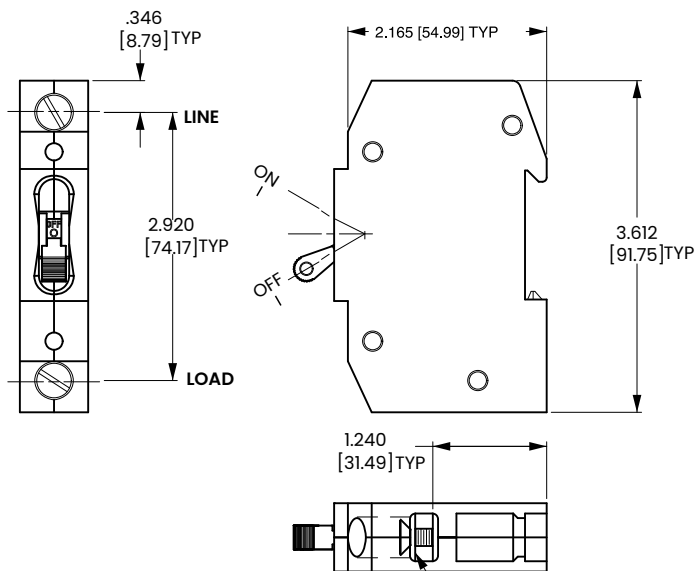

TABLE A TIGHTENING TORQUE SPECIFICATIONS	
THREAD SIZE	TORQUE
#6-32[M3] HARDWARE	7-9 IN-LBS [0.8-1.0 NM]
#6-32 THD TERMINAL SCREW	15-20 IN-LBS [1.7-2.3 NM]

Notes:
 1 Tolerance ± 0.020 [.51] unless otherwise specified.

Dimensional Specs

Rocker

inches [millimeters]

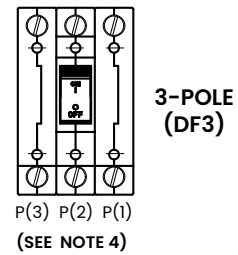
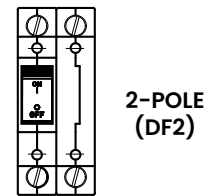
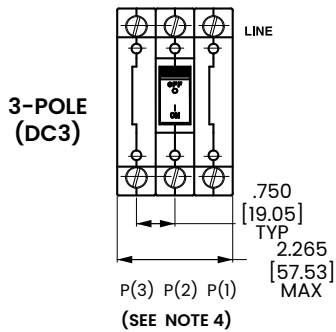
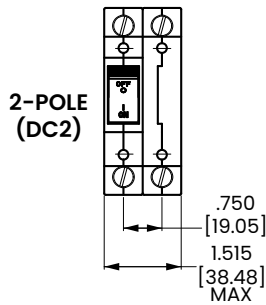
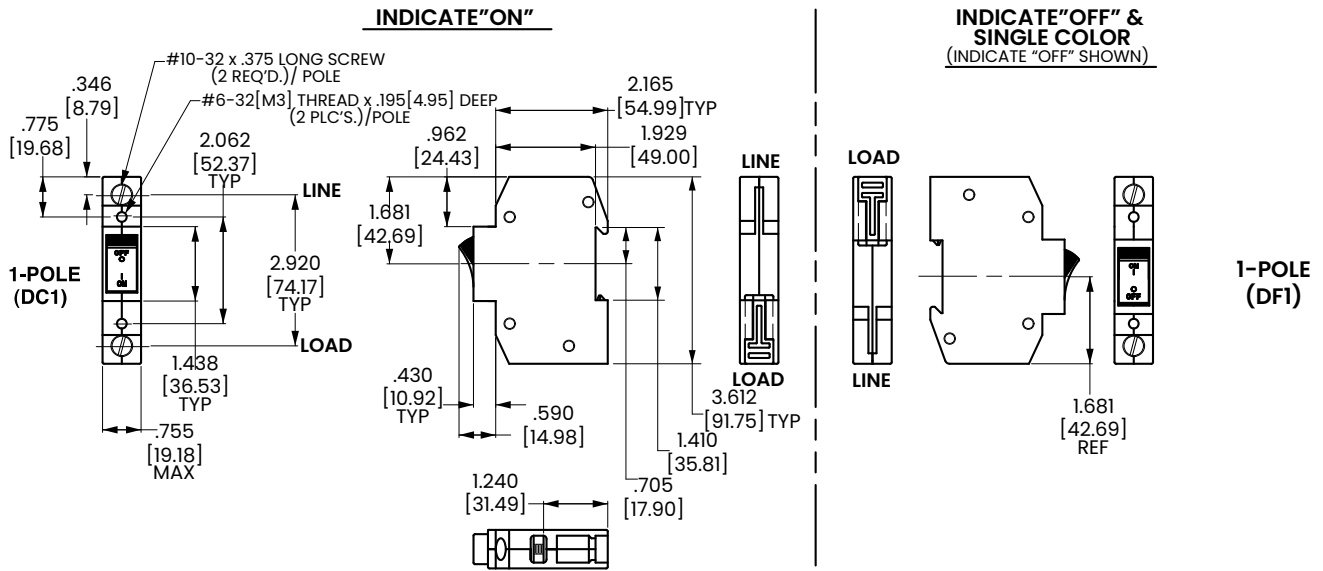

STANDARD 35mm SYMMETRICAL DIN RAIL
(35 X 7.5 OR 35 X 15mm DIN EN50022)

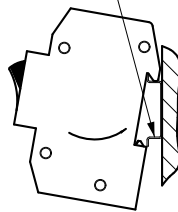

ASSEMBLY

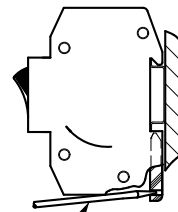

REMOVAL

Notes:

- 1 Tolerance ± 0.20 [.51] unless otherwise specified.
- 2 Dimensions apply to all variations shown. Notice that circuit breaker line and load terminal orientation on indicate OFF is opposite of indicate ON.
- 3 For pole orientation with horizontal legend, rotate front view clockwise 90°.

Dimensional Specs Handle

inches [millimeters]

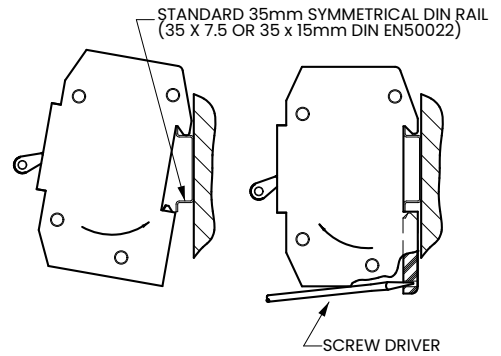
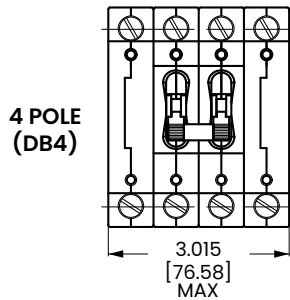
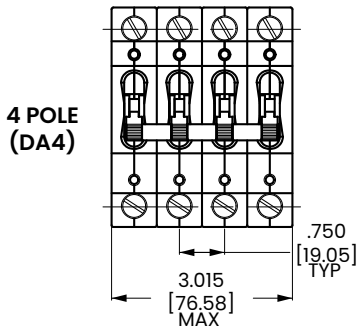
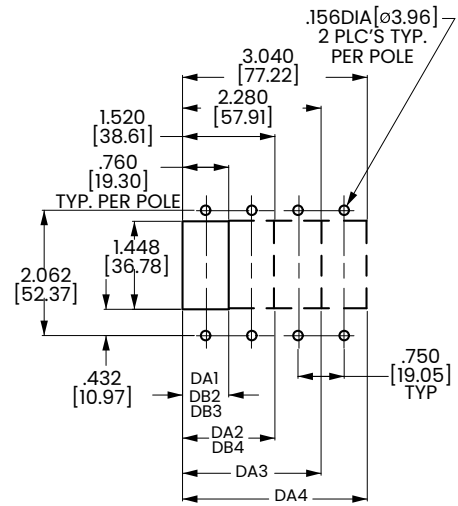
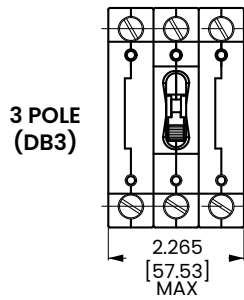
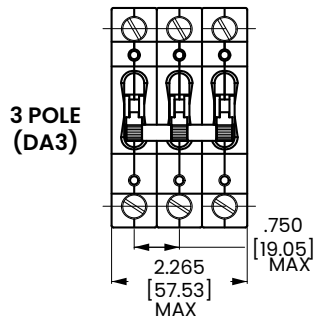
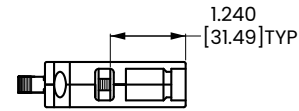
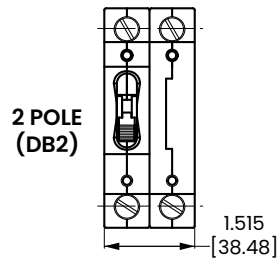
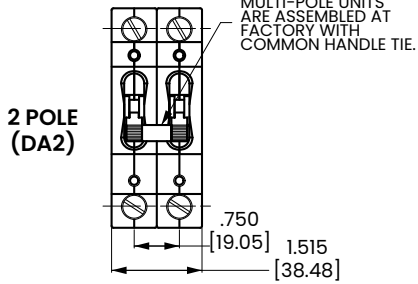
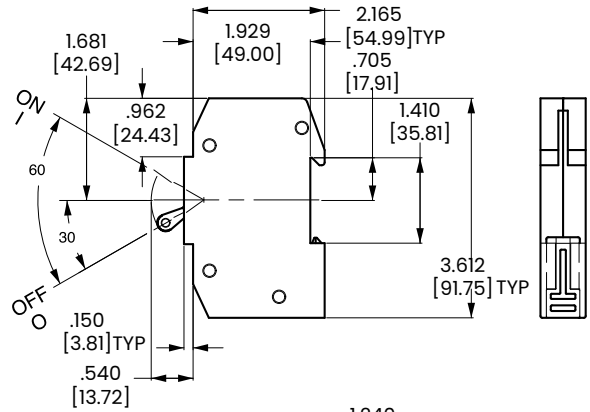
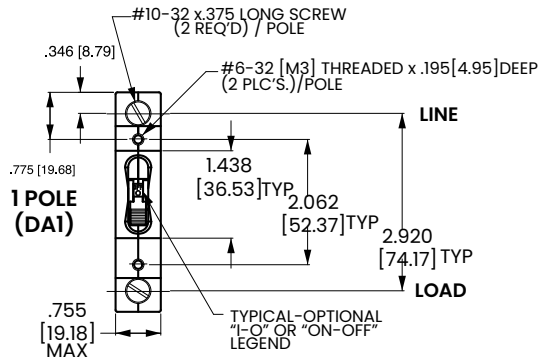

Notes:
1 Tolerance ±.010 [.25] unless otherwise specified.

E-Series

Hydraulic-Magnetic Circuit Breaker

PRODUCT WEBPAGE

request sample, configure part

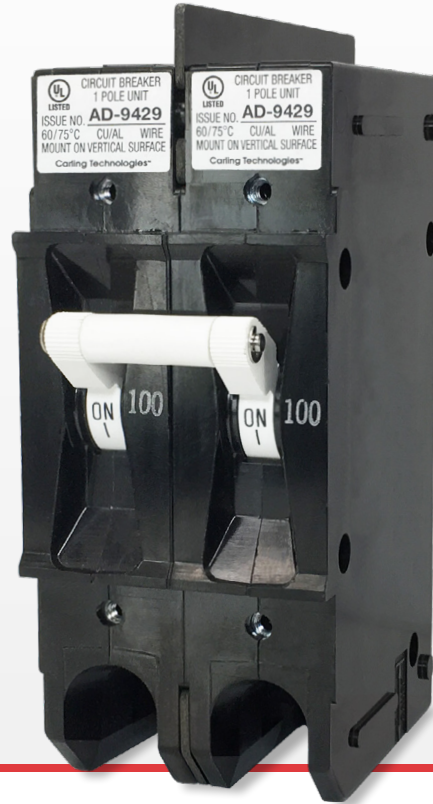

High Current and Voltage Breaker Qualified Supplementary Protector

The E-Series hydraulic-magnetic circuit breaker is designed for higher current and voltage applications and qualified, as per agency approval, for branch circuit protection or as a supplementary protector. E-Series breakers are available as a one to six pole configuration and are rated up to 125 amps and 600VAC or 125VDC, with a max IC of 10,000 amps.

1-6 Poles **1-100** Amps **600** VAC Max **125** VDC Max

Typical Applications

- Renewable Energy
- Industrial Automation
- High Voltage/Current Applications
- Military
- Generators
- Commercial Food

Tech Specs

Electrical

Maximum Voltage	600VAC 50/60 Hz, 125VDC (See Table A)
Current Ratings	Standard current coils: 0.100, 0.250, 0.500, 1.00, 2.50, 5.00, 7.50, 10.0, 15.0, 20.0, 25.0, 30.0, 50.0, 60.0, 70.0 & 100 Amp.
Auxiliary Switch Rating	SPDT; 10.1A 250VAC, 1.0A 65VDC; 0.5A 80VDC, 0.1A 125VAC (with gold contacts).
Insulation Resistance	Minimum of 100 Megohms at 500 VDC.
Dielectric Strength	UL, CSA: 2200 V 50/60 Hz for one minute between all electrically isolated terminals. E-Series Circuit Breakers comply with the 8mm spacing and 3750V 50/60 Hz dielectric requirements from hazardous voltage to operator accessible surfaces, between adjacent poles and from main circuits to auxiliary circuits per Publications EN 60950 and VDE 0805.
Resistance, Impedance	Values from Line to Load Terminal - based on Series Trip Circuit Breaker

RESISTANCE, IMPEDANCE VALUES
from Line to Load Terminals

(Values Based on Series Trip Circuit Breaker)

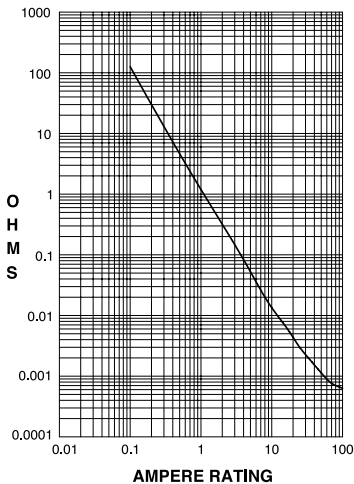

CURRENT (AMPS)	TOLERANCE (%)
0.10 - 5.0	± 15
5.1 - 20.0	± 25
20.1 - 50.0	± 35

Pulse Tolerance Curves

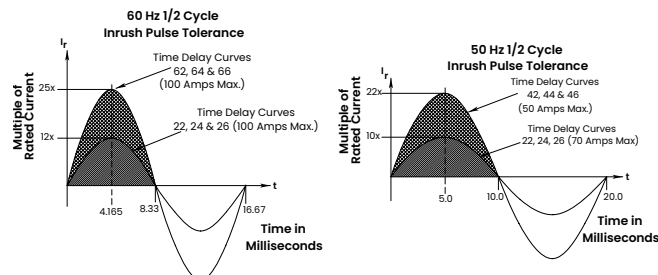

Mechanical

Endurance	10,000 ON-OFF operations @ 6 per minute; with rated current & voltage.
Trip Free	All E-Series circuit breakers will trip on overload, even when Handle is forcibly held in the ON position.
Trip Indication	The operating Handle moves positively to the OFF position when an overload causes the breaker to trip.

Physical

Number of Poles	1-6
Mounting	A 3" minimum spacing must be provided between the circuit breaker arc venting area on back connected E-Series circuit breakers and grounded obstructions. E-Series circuit breakers must be mounted on a vertical surface.
Connectors, Box Type	Front connected E-Series circuit breakers are supplied with box type pressure connectors that accept copper or aluminum conductors as follows: 1/0-14 Copper, 1/0-12 Aluminum.
Internal Circuit Configuration	Series and Switch Only, (with or Configuration without auxiliary switch). Shunt with current coils.
Weight	Approximately 252 grams/pole (Approximately 9 ounces/pole)
Standard Colors	Housing-Black; Actuator - See Ordering Scheme.

Environmental

Designed in accordance with requirements of specification MIL PRF-55629 & MIL-STD-202G as follows:

Shock	Withstands 100 Gs, 6ms, sawtooth while carrying rated current per Method 213, Test Condition "I".
Vibration	Withstands 0.060" excursion from 10-55 Hz, and 10 Gs 55-500 Hz, at rated current per Method 204C, Test Condition A.
Moisture Resistance	Method 106D, i.e., ten 24-hour cycles @ + 25°C to +65°C, 80-98% RH.
Salt Spray	Method 101, Condition A (90-95% RH @ 5% NaCl Solution, 96 hrs).
Thermal Shock	Method 107D, Condition A (Five cycles @ -55°C to +25°C to +85°C to +25°C).
Operating Temperature	-40° C to +85° C

Tech Specs

Tables

Table A: Lists UL Listed (489) & CSA Certified (C22.2 No. 5) configurations & performance capabilities as a Molded Case Circuit Breaker.

UL489 Listed Branch Circuit Breakers						
Circuit Configuration	Voltage			Current Rating	Interrupting Capacity (Amps)	High Interrupting Capacity (Amps)
	Max Rating	Frequency	Phase	Full Load Amps	Without Backup Fuse	
Series	80	DC	-	0.10 - 100	5,000	50,000
	125		-			10,000
	120		-	-		
	240	50/60	1	0.10 - 125	5,000	-
	120 / 240			0.10 - 30		10,000
				31 - 100		-
				0.10 - 30		10,000
				31 - 100		-
	240			3		101 - 125
	240	0.10 - 100	5,000		-	

Table B: Lists UL Recognized & CSA Accepted configurations & performance capabilities as a Component Supplementary Protector.

Component Supplementary Protectors										
Circuit Configuration	Voltage			Current Rating		Short Circuit Capacity (Amps)		Application Codes		
	Max Rating	Frequency	Phase	Full Load Amps	General Purpose Amps	UL/CSA		UL	CSA	
						With Backup Fuse	Without Backup Fuse			
Series & Shunt	125	DC	-	0.02 - 100	-	-	5,000	TC1,2, OLI, UI	TC1,2, OLI, UI	
	125			-	101 - 120			TC1,2, OL0, UI	TC1,2, OL0, UI	
	150			0.02 - 125	TC1, OL0, U3			TC1, OL0, U3		
	160			-	TC1,2, OLI, UI			TC1,2, OLI, UI		
	150 / 300			-	TC1,2, OLI, UI			TC1,2, OLI, UI		
	120 / 240	50/60	1	-	0.02 - 100	-	-	TC1,2, OLI, UI	TC1,2, OLI, UI	
	240			TC1,2, OL0, UI	TC1,2, OL0, UI					
	250			10,000	TC1,2, OLI, UI			TC1,2, OLI, UI		
	277			-	5,000			TC1,2, OLI, C1	TC1,2, OLI, C1	
	480			10,000	-			0.02 - 50	TC1,2, OLI, UI	TC1,2, OLI, UI
	480 ¹								TC1,2, OLI, C1	TC1,2, OLI, C1
	600								TC1,2, OLI, C1	TC1,2, OLI, C1
	600 ²								TC1,2, OLI, C1	TC1,2, OLI, C1
600	-	0.02 - 125	-	5,000	TC1, OL0, U3	TC1, OL0, U3				
Switch Only	125	DC	-	0.02 - 120						
	160	50/60	1							
	240									
	277									
	480									
	600									1 & 3

Notes:

- 1 Per pole opposite polarity rating - Delta Configuration.
- 2 4 Poles connected in series
- 3 Requires branch circuit backup with a UL Listed Type K5 or RK5 fuse rated 15A minimum and no more than 4 times full load amp rating and not to exceed 225A.

Tech Specs

Table C: Lists UL Recognized, CSA Accepted and VDE Certified configurations and performance capabilities as a Component Supplementary Protector.

Component Supplementary Protectors With VDE										
Circuit Configuration	Voltage			Current Rating Full Load Amps	Short Circuit Capacity (Amps)			Application Codes		Construction Notes
	Max Rating	Frequency	Phase		UL/CSA		VDE (Icn)	UL	CSA	
				With Backup Fuse	Without Backup Fuse	Without Backup Fuse				
Series & Shunt	125	DC	-	0.1 - 100	-	5,000	5,000	TC1,2, OLI, UI	TC1,2, OLI, UI	1 or 2 Poles
	240	50/60	1 & 3		10,000	-	4,000	TC1,2, OLI, CI	TC1,2, OLI, CI	1-5 poles. Up to 4 Current Poles, 1 Voltage Pole
	415				TC1,2, OLI, CI	TC1,2, OLI, CI	2-5 poles. Up to 4 Current Poles, 1 Voltage Pole			
Switch Only	125	DC	-	0.1 - 125						
	240	50/60	1 & 3	0.1 - 100						
	415									

Notes:
 1 Requires branch circuit backup with a UL LISTED Type K5 or RK5 fuse rated 15A minimum and no more than 4 times full load amp rating and not to exceed 225 amps.

Table D: Lists UL Recognized, CSA Accepted configurations and performance capabilities as Protectors, Supplementary for Marine Electrical and Fuel Systems (Guide PEQZ2, File E75596). Ignition Protected per UL 1500. UL Classified Small Craft Electrical Devices, Marine in accordance with ISO 8846 (Guide UZMK, File MQ1515) as Marine Supplementary Protectors.

UL1500 (Marine Ignition Protection)							
Circuit Configuration	Voltage			Current Rating Full Load Amps	Short Circuit Capacity (Amps) With Backup Fuse	Application Codes	
	Max Rating	Frequency	Phase			UL	CSA
Series	65	DC	-	0.2 - 100	5,000	TC1,2, OLI, UI	TC1,2, OLI, UI
	125	50/60	1		1,500		
	250						

Agency Approvals

UL 1077	Component Recognition Program as Protectors, Supplementary (Guide QVNU2, File E75596)
UL 1500	Component Recognition Program as Manual Motor Controls (Guide NLRV2, File E135367)
UL 489	Protectors, Supplementary for Marine Electrical & Fuel Systems (Guide PEQZ2, File E75596) Ignition Protection
CSA Accepted	Component Supplementary Protector (Class 3215 30, File 047848 0 000) CSA Standard C22.2 No. 235
CSA Certified	Circuit Breaker Molded Case (Class 1432 01, File 093910), CSA Standard C22.2 No. 5.1 - M
TUV Certified	EN60934 under License No. R72031056
VDE Certified	EN60934, VDE 0642 under File No. 10537

Time Delay Specs

To view all hydraulic-magnetic circuit breaker time delay values, please visit www.carlingtech.com/sites/default/files/documents/Carling-HM-CB-Time-Delays.pdf

Ordering Scheme

UL 1077 Recognized

Sample Part Number

E A 2 - B 0 - 24 - 450 - 1 2 A - C B

Selection 1 2 3 4 5 6 7 8 9 10 11 12

1. SERIES

E

2. ACTUATOR

A Handle, one per pole

3. POLES ¹

1 One	3 Three	5 Five
2 Two	4 Four	6 Six

4. CIRCUIT ²

A Switch Only (no coil) ³	E Shunt Trip (voltage)
B Series Trip (current)	F Relay Trip (current)
C Series Trip (voltage)	G Relay Trip (voltage)
D Shunt Trip (current)	

5 AUXILIARY SWITCH ⁴

0 without Auxiliary Switch	6 S.P.S.T. 0.110 Q.C. Terminals
2 S.P.D.T. 0.110 Q.C. Terminals	7 S.P.S.T. 0.110 Q.C. Terminals (Gold Contacts)
3 S.P.D.T. 0.139 Solder Lug	8 S.P.S.T. 0.187 Q.C. Terminals
4 S.P.D.T. 0.110 Q.C. Terminals (Gold Contacts)	9 S.P.D.T. 0.187 Q.C. Terminals

6. FREQUENCY & DELAY

03 DC 50/60Hz, Switch Only ³	36 DC, 50/60Hz Long
10 DC Instantaneous ⁵	62 50/60Hz Short, High-inrush
12 DC Short	64 50/60Hz Medium, High-inrush
14 DC Medium	66 50/60Hz Long, High-inrush
16 DC Long	74 DC, Medium, High-inrush
20 50/60Hz Instantaneous ⁵	76 DC, Long, High-inrush
22 50/60Hz Short	92 DC, 50/60Hz Short, High-inrush ⁶
24 50/60Hz Medium	94 DC, 50/60Hz Medium, High-inrush ⁶
26 50/60Hz Long	96 DC, 50/60Hz Long, High-inrush ⁶
30 DC, 50/60Hz Instantaneous	
32 DC, 50/60Hz Short	
34 DC, 50/60Hz Medium	

7. CURRENT RATING (AMPERES) ⁴

CODE	AMPERES						
020	0.020	235	0.350	430	3.000	614	14.000
025	0.025	240	0.400	435	3.500	615	15.000
030	0.030	245	0.450	440	4.000	616	16.000
035	0.035	250	0.500	445	4.500	617	17.000
040	0.040	255	0.550	450	5.000	618	18.000
045	0.045	260	0.600	455	5.500	620	20.000
050	0.050	265	0.650	460	6.000	622	22.000
055	0.055	270	0.700	465	6.500	624	24.000
060	0.060	275	0.750	470	7.000	625	25.000
065	0.065	280	0.800	475	7.500	630	30.000
070	0.070	285	0.850	480	8.000	635	35.000
075	0.075	290	0.900	485	8.500	640	40.000
080	0.080	295	0.950	490	9.000	650	50.000
085	0.085	410	1.000	495	9.500	660	60.000
090	0.090	512	1.250	610	10.000	670	70.000
090	0.095	415	1.500	710	10.500	680	80.000
210	0.100	517	1.750	611	11.000	690	90.000
215	0.150	420	2.000	711	11.500	810	100.000
220	0.200	522	2.250	612	12.000	811	110.000
225	0.250	425	2.500	712	12.500	812	120.000
230	0.300	527	2.750	613	13.000	912	125.000 ⁸

OR VOLTAGE COIL ⁵

CODE	RATING	TRIP VOLTS						
A06	6DC	5DC	A65	65DC	55DC	J48	48AC	40AC
A12	12DC	10DC	B25	120DC	100DC	J65	65AC	55AC
A18	18DC	15DC	J06	6AC	5AC	K20	120AC	65AC
A24	24DC	20DC	J12	12AC	10AC	L40	240AC	130AC
A32	32DC	25DC	J18	18AC	15AC			
A48	48DC	40DC	J24	24AC	20AC			

Configure Complete Part Number >

Browse Standard Parts >

8. TERMINAL ¹²

	BACK CONNECTED (FRONT MOUNTED ONLY)	MAX. RATING
1 ⁹	10-32 Stud (All Terminals)	50 A
2 ⁹	1/4-20 Stud (All Terminals)	120 A
A ⁹	M5 Stud (Line & Load)	50 A
B ⁹	M6 Stud (Line & Load)	100 A
FRONT CONNECTED (BACK MOUNTED ONLY)		
3 ¹⁰	Box Wire Connector (Line & Load)	100 A
C ¹¹	Box Wire Connector with Pressure Plate (Line & Load)	100 A
4	10-32 Screw (Line & Load)	50 A
D	M5 Screw (Line & Load)	50 A
5	10-32 "Bus-Type" Screw (Line), 10-32 Screw (Load)	50 A
E	M5 "Bus-Type" Screw (Line), 10-32 Screw (Load)	50 A
6 ¹⁰	10-32 "Bus-Type" Screw (Line), Box Wire Connector (Load)	100 A
F ¹¹	10-32 "Bus-Type" Screw (Line), Box Wire Connector with Pressure Plate (Load)	100 A
7	1/4-20 Screw (Line & Load)	100 A
G	M6 Screw (Line & Load)	100 A
8	1/4-20 "Bus-Type" Screw (Line), 1/4-20 Screw (Load)	100 A
H	M6 "Bus-Type" Screw (Line), M6 Screw (Load)	100 A
9 ¹⁰	1/4-20 "Bus-Type" Screw (Line), Box Wire Connector (Load)	100 A
J ¹¹	1/4-20 "Bus-Type" Screw (Line), Box Wire Connector with Pressure Plate (Load)	100 A

9 ACTUATOR COLOR & LEGEND ¹³

Actuator Color	I-O	ON-OFF	Dual	Legend Color
White	A	B	1	Black
Black	C	D	2	White
Red	F	G	3	White
Green	H	J	4	White
Blue	K	L	5	White
Yellow	M	N	6	Black
Gray	P	Q	7	Black
Orange	R	S	8	Black

10. MOUNTING / BARRIERS

BACK CONNECTED (FRONT MOUNTED ONLY)	
Mounting Inserts	
A	6-32
B	ISO M3
FRONT CONNECTED (BACK MOUNTED ONLY) ¹⁴	
Back Mounting Foot Type	
C	Short
D	Short
E	Long
F	Long
Front Mounting Inserts (Optional Use)	
	6-32
	ISO M3
	6-32
	ISO M3

11. MAXIMUM APPLICATION RATING ¹⁵

A	65VDC, 120A	G	600VAC, 100A ¹⁶
B	125VDC, 120A	H	480VAC, 100A ¹⁶
C	120/240VAC, 100A	J	415VAC, 100A ¹⁶
D	240VAC, 100A	L	160VDC, 100A ¹⁶
E	277/480VAC, 100A ¹⁶	T	125VDC/240VAC, 100A
F	277VAC, 100A	W	125VDC/415VAC, 100A ¹⁶

12. AGENCY APPROVAL

B	UL 1077 / UL 508 Recognized & CSA Accepted
D	UL 1077 Recognized, CSA Accepted, & VDE Certified

Notes:

- VDE approval on 1-5 poles only. Standard multi-pole units identical poles except when specifying auxiliary switch (Note 4). For mixed ratings, consult factory.
- Switch Only & Series Trip construction available with either front or back connected terminals. Shunt construction available with back connected terminals. (Terminal Codes 1 & 2) only. Circuit Codes B,C & D are VDE approved.
- Switch Only construction; 30 amps or less select Current Rating Code 630; 31-70 amps, select Current Rating code 670; 71-100 amps, select Current Rating Code 810; 101-125 amps Select Current Rating Code 912. Switch Only is VDE approved only if tied to a protected pole.
- Auxiliary Switch available on Switch Only and Series Trip units. On multi-pole units, only one auxiliary switch is normally supplied mounted in the extreme right pole. Back mounted units require special mounting provisions when auxiliary switch is specified. VDE approval on Auxiliary Switch Codes 0,2,3 & 4 only.
- Voltage trip coils are not rated for continuous duty. Available only with frequency & delay codes 10 & 20. Series trip construction with a voltage coil is VDE approved only if tied to a protected pole.
- Frequency & delay codes 92, 94 & 96 are not VDE Certified.
- Current Coil Ratings 0,100 - 100 amps are VDE Certified.
- 125 A rating (Code 912) available as a Switch Only (Circuit Code A), rated 125 VDC (Code B).
- An Anti-Flash Over Barrier is supplied between poles on multi-pole units with 10-32 (Terminal Code 1), 1/4-20 (Code 2), M5 (Code A), and M6 (Code B) terminals per UL requirement.
- Box Wire Connector will accept #14 through 0 AWG. copper wire or #12 through 0 AWG. aluminum wire.
- Box wire connector with pressure plate for stranded wire. Consult factory
- Terminal Codes A,B,D,E,G & H are not VDE Certified.
- VDE approvals require Dual (I-O, ON-OFF) or I-O markings on all handles.
- Back Mounted breakers can also be front mounted by utilizing the proper front panel mounting inserts normally supplied. However, terminal connections must be made prior to mounting.
- Application ratings B, D, J, T & W are available with VDE.
- 415, 480 & 600 VAC ratings require 3 or 4 pole break 30 and 2 pole break 10.

Ordering Scheme

UL 489 Listed

Sample Part Number

E A 2 - B 0 - 24 - 450 - 1 2 A - C C

Selection 1 2 3 4 5 6 7 8 9 10 11 12

1. SERIES

E

2. ACTUATOR

A Handle, one per pole

3. POLES ¹

1 One	3 Three	5 Five
2 Two	4 Four	6 Six

4. CIRCUIT ²

B Series Trip (current) C Series Trip (voltage) ³

5 AUXILIARY SWITCH ⁴

0 without Auxiliary Switch	6 S.P.S.T. 0.110 Q.C. Terminals
2 S.P.D.T. 0.110 Q.C. Terminals	7 S.P.S.T. 0.110 Q.C. Terminals
3 S.P.D.T. 0.139 Solder Lug	(Gold Contacts)
4 S.P.D.T. 0.110 Q.C. Terminals	8 S.P.S.T. 0.187 Q.C. Terminals
(Gold Contacts)	9 S.P.D.T. 0.187 Q.C. Terminals

6. FREQUENCY & DELAY

10 DC Instantaneous ⁵	24 50/60Hz Medium
12 DC Short	26 50/60Hz Long
14 DC Medium	62 50/60Hz Short, High-inrush
16 DC Long	64 50/60Hz Medium, High-inrush
20 50/60Hz Instantaneous ⁵	66 50/60Hz Long, High-inrush
22 50/60Hz Short	74 DC, Medium, High-inrush
	76 DC, Long, High-inrush

7. CURRENT RATING (AMPERES) ⁷

CODE	AMPERES						
020	0.020	235	0.350	430	3.000	614	14.000
025	0.025	240	0.400	435	3.500	615	15.000
030	0.030	245	0.450	440	4.000	616	16.000
035	0.035	250	0.500	445	4.500	617	17.000
040	0.040	255	0.550	450	5.000	618	18.000
045	0.045	260	0.600	455	5.500	620	20.000
050	0.050	265	0.650	460	6.000	622	22.000
055	0.055	270	0.700	465	6.500	624	24.000
060	0.060	275	0.750	470	7.000	625	25.000
065	0.065	280	0.800	475	7.500	630	30.000
070	0.070	285	0.850	480	8.000	635	35.000
075	0.075	290	0.900	485	8.500	640	40.000
080	0.080	295	0.950	490	9.000	650	50.000
085	0.085	410	1.000	495	9.500	660	60.000
090	0.090	512	1.250	610	10.000	670	70.000
090	0.095	415	1.500	710	10.500	680	80.000
210	0.100	517	1.750	611	11.000	690	90.000
215	0.150	420	2.000	711	11.500	810	100.000
220	0.200	522	2.250	612	12.000	811	110.000
225	0.250	425	2.500	712	12.500	812	120.000
230	0.300	527	2.750	613	13.000	912	125.000 ⁸

OR VOLTAGE COIL ⁵

CODE	RATING	TRIP VOLTS						
A06	6DC	5DC	A65	65DC	55DC	J48	48AC	40AC
A12	12DC	10DC	B25	120DC	100DC	J65	65AC	55AC
A18	18DC	15DC	J06	6AC	5AC	K20	120AC	65AC
A24	24DC	20DC	J12	12AC	10AC	L40	240AC	130AC
A32	32DC	25DC	J18	18AC	15AC			
A48	48DC	40DC	J24	24AC	20AC			

8. TERMINAL ⁷

	BACK CONNECTED (FRONT MOUNTED ONLY)	MAX. RATING
1 ⁸	10-32 Stud (All Terminals)	50 A
2 ⁸	1/4-20 Stud (All Terminals)	125 A
	FRONT CONNECTED (BACK MOUNTED ONLY)	
3 ⁹	Box Wire Connector (Line & Load)	100 A
C ¹⁰	Box Wire Connector with Pressure Plate (Line & Load)	100 A
4	10-32 Screw (Line & Load)	50 A
5	10-32 "Bus-Type" Screw (Line), 10-32 Screw (Load)	50 A
6 ⁹	10-32 "Bus-Type" Screw (Line), Box Wire Connector (Load)	100 A
F ¹⁰	10-32 "Bus-Type" Screw (Line), Box Wire Connector with Pressure Plate (Load)	100 A
7	1/4-20 Screw (Line & Load)	100 A
8	1/4-20 "Bus-Type" Screw (Line), 1/4-20 Screw (Load)	100 A
9 ⁹	1/4-20 "Bus-Type" Screw (Line), Box Wire Connector (Load)	100 A
J ¹⁰	1/4-20 "Bus-Type" Screw (Line), Box Wire Connector with Pressure Plate (Load)	100 A

9 ACTUATOR COLOR & LEGEND ¹²

Actuator Color	ON-OFF	Dual	Legend Color
White	B	1	Black
Black	D	2	White
Red	G	3	White
Green	J	4	White
Blue	L	5	White
Yellow	N	6	Black
Gray	Q	7	Black
Orange	S	8	Black

10. MOUNTING / BARRIERS

	BACK CONNECTED (FRONT MOUNTED ONLY)	
	Mounting Inserts	
A	6-32	
B	ISO M3	
	FRONT CONNECTED (BACK MOUNTED ONLY) ¹¹	
	Back Mounting Foot Type	Front Mounting Inserts (Optional Use)
C	Short	6-32
D	Short	ISO M3
E	Long	6-32
F	Long	ISO M3

11. MAXIMUM APPLICATION RATING

1 120 VAC	C 120/240 VAC, 100A ¹³
B 125 VDC	D 240 VAC, 100A

12. AGENCY APPROVAL

C UL 489 Listed & CSA Certified
F UL 489 Listed, CSA Certified, & VDE Certified

Notes:

- Standard multi-pole units identical poles except when specifying auxiliary switch (Note 4). For mixed ratings, consult factory. VDE Certification on 1-5 poles only.
- Series Trip construction available with either front or back connected terminals.
- Series Trip construction with a voltage coil is not available as a single pole unit and must be tied to a protected pole.
- On multi-pole units, only one auxiliary switch is normally supplied mounted in the extreme right pole per Figure A. Back mounted units require special mounting provisions when auxiliary switch is specified. VDE Certification on auxiliary switch codes 0, 2, 3 & 4 only.
- Voltage Trip Coils are not rated for continuous duty. Available only with Frequency & Delay Codes 10 & 20.
- Frequency & Delay Codes 92, 94 & 96 are not VDE Certified.
- Current Ratings under 0.100 amps are not VDE Certified.
- An Anti-Flash Over Barrier is supplied between poles on multi-pole units with 10-32 Stud (Terminal Code 1) or 1/4-20 Stud (Code 2) terminals per UL requirement.
- Box Wire Connector will accept #14 through 0 AWG. copper wire or #12 through 0 AWG. aluminum wire.
- Box Wire Connector with Pressure Plate for stranded wire. Consult factory.
- Back Mounted breakers can also be front mounted by utilizing the proper front panel mounting inserts normally supplied. However, terminal connections must be made prior to mounting.
- VDE Certification requires dual (I-O, ON-OFF) markings on all handles.
- Not available with VDE Certification.

[Configure Complete Part Number >](#)

[Browse Standard Parts >](#)

Dimensional Specs

inches [millimeters]

MOUNTING INSERTS:

#6-32[M3]THREADX.220[5.59]
MIN. DEEP (2 PLCS)/POLE

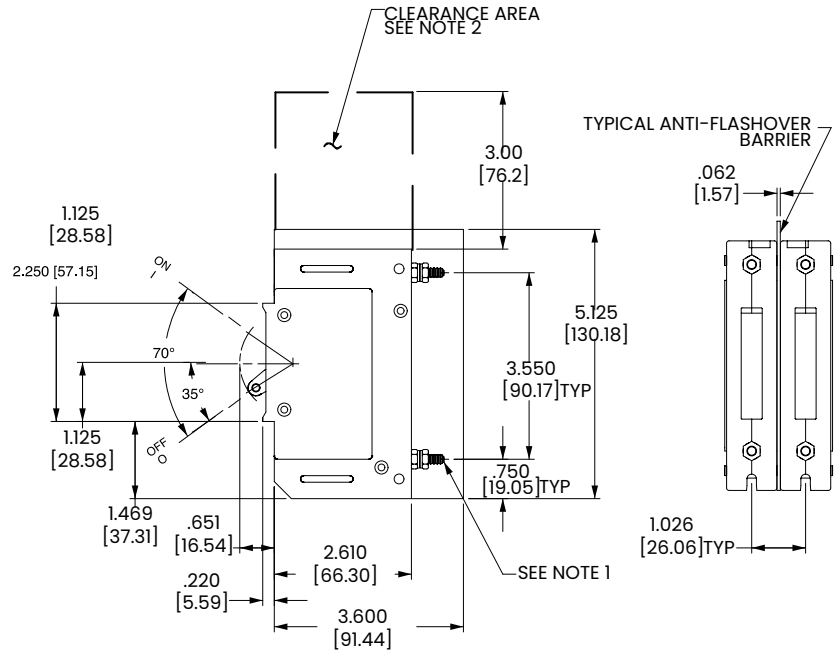
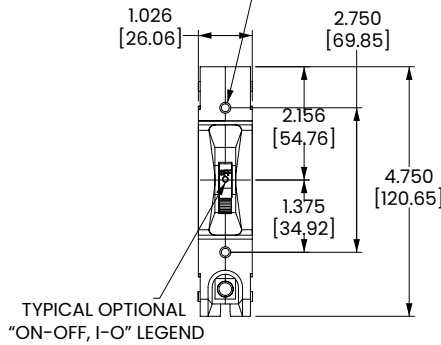

PANEL CUTOUT DETAIL

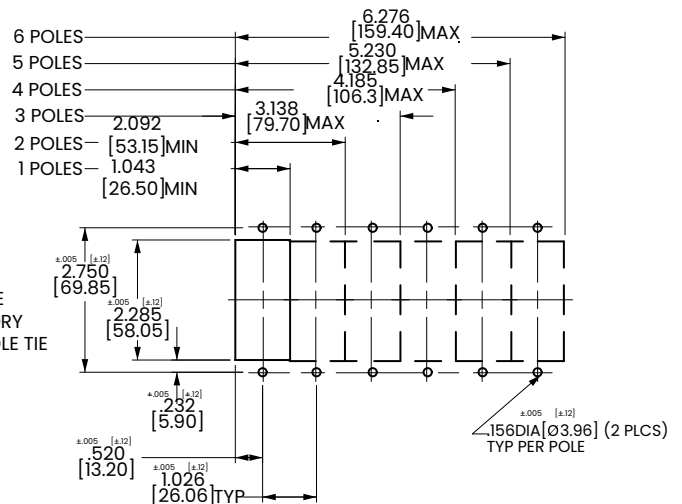
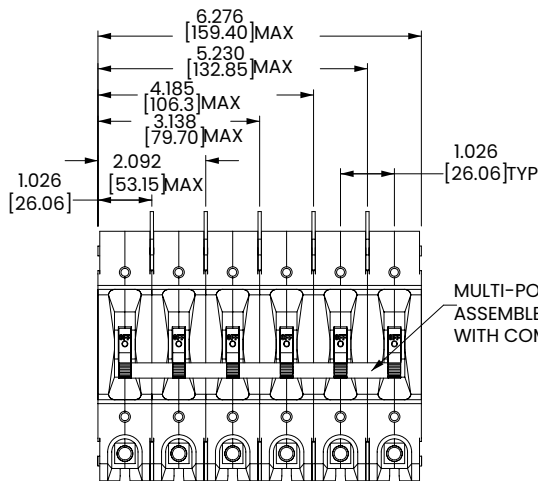

Notes:

- 1 1/4 -20 stud terminal in Series Trip circuit configuration shown.
- 2 A 3" min spacing must be provided between the circuit breaker arc venting area of back connected E-Series circuit breaker and grounded obstructions.
- 3 Tolerance ± 0.020 [.51] unless otherwise specified.
- 4 Circuit breakers must be mounted on vertical surface.

Dimensional Specs

inches [millimeters]

MOUNTING INSERTS:

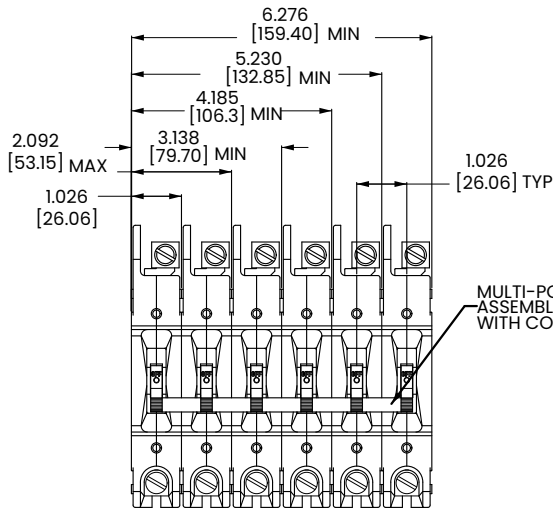
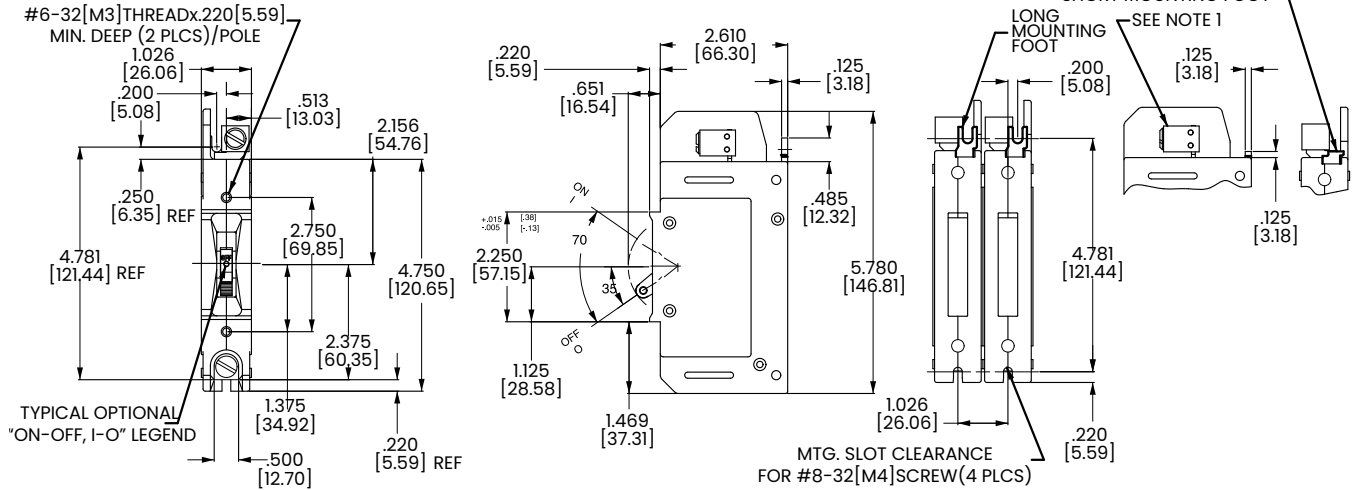

PANEL CUTOUT DETAIL

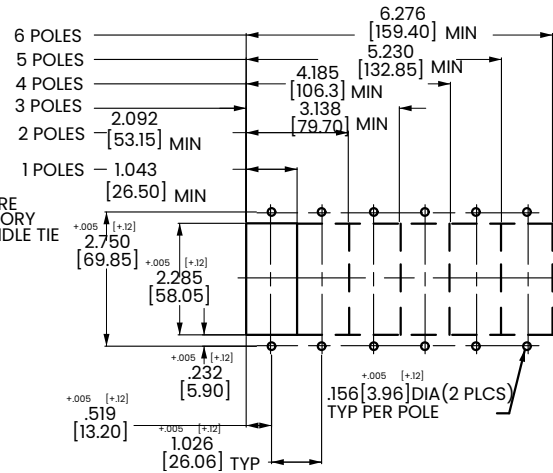

- Notes:
- 1 Tolerance ± 0.020 [.51] unless otherwise specified.
 - 2 Box wire connector terminal in Series Trip circuit configuration shown.
 - 3 Circuit breakers must be mounted on vertical surface.

Circuit & Terminal Diagram

inches [millimeters]

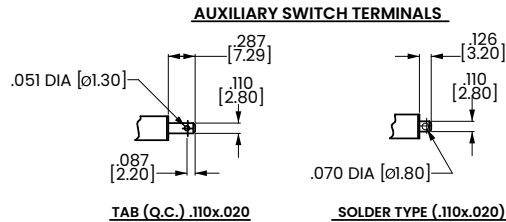
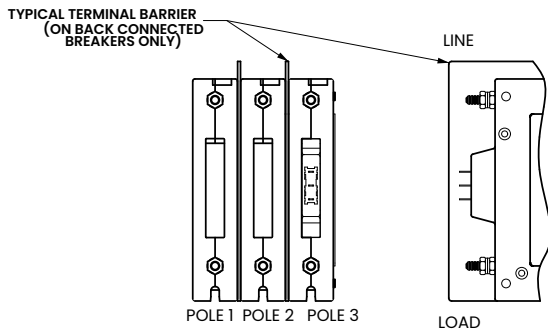
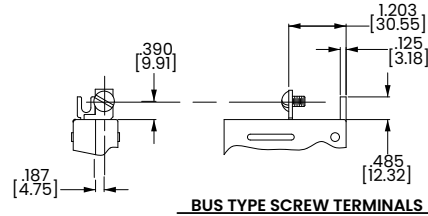
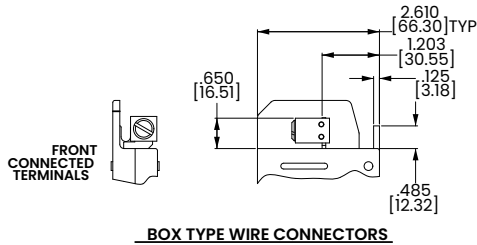
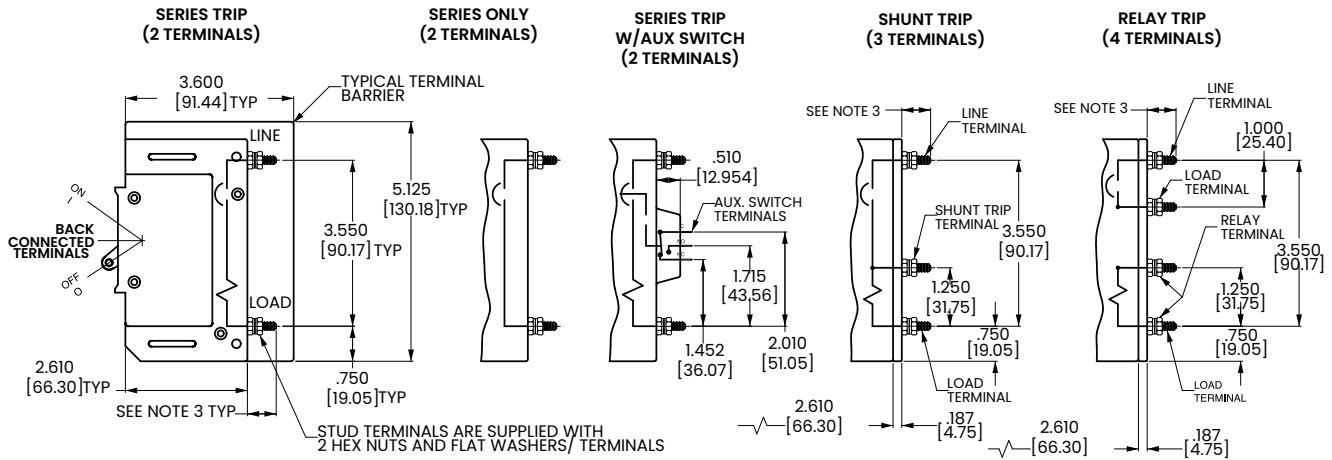

TABLE A TIGHTENING TORQUE SPECIFICATIONS		
THREAD SIZE TERMINAL TYPE	WIRE SIZE	TORQUE
#6-32 [M3] HARDWARE	—	7-9 IN-LBS [0.8-1.0 NM]
#10-32 THD TERMINAL SCREW	ALL	15-20 IN-LBS [1.7-2.3 NM]
1/4-20 THD TERMINAL SCREW	ALL	30-35 IN-LBS [3.4-4.0 NM]
#10-32 STUD	ALL	15-20 IN-LBS [1.7-2.3 NM]
1/4-20 STUD	ALL	30-35 IN-LBS [3.4-4.0 NM]
BOX WIRE CONNECTOR	14-10 AWG	35 IN-LBS [4.0 NM]
	8 AWG	40 IN-LBS [4.5 NM]
	6-4 AWG	45 IN-LBS [5.1 NM]
	3-1/0 AWG	50 IN-LBS [5.7 NM]

Notes:

- 1 Tolerance ±.020 [.51] unless otherwise specified.
- 2 0-50 amps: 10-32 & M5 Studs .625±.062/15.88±1.574 long.
- 3 51-120 amps: 1/4-20 & M6 Studs .750±.062/19.05±1.574 long.

F-Series

Hydraulic-Magnetic Circuit Breaker

PRODUCT WEBPAGE

request sample, configure part



Handles High Current Battery Disconnect for Contingency Power

The F-Series hydraulic-magnetic circuit breaker accommodates current ratings from 100 to 700 amps, as per agency approvals. An optional 25 millivolt metering shunt allows for safely monitoring current output. These breakers are available as a one to three pole configuration with maximum voltage ratings of 277VAC/125VDC and max IC of 50,000 amps.

1-3	100-700	277	125
Poles	Amps	VAC Max	VDC Max

Typical Applications

- Higher Amperage Applications
- Battery Disconnect Systems
- Renewable Energy
- Industrial Automation
- Telecom
- Military

Tech Specs

Electrical

Maximum Voltage	125VDC, 277VAC
Current Ratings	Standard current coils: 100, 125, 150, 175, 225, 250 amps. 300, 350, 400, 500, 600, 700 amps available as parallel pole construction.
Auxiliary Switch Rating	SPDT; 10.1 Amps @ 250VAC, 1.0 Amps @ 65VDC, 0.5 Amps @ 80VDC 0.1 Amps @ 125VAC (with gold contacts).
Insulation Resistance	Minimum: 100 Megohms at 500 VDC
Dielectric Strength	1960 VAC, 50/60 Hz for one minute between all electrically isolated terminals, except 2500 VAC for one minute between alarm/aux. switch and main terminals with contacts in open and closed position. F-Series circuit breakers comply with the 8mm spacing & 3750VAC 50/60 Hz dielectric requirements from hazardous voltage to operator accessible surfaces, between adjacent poles and from main circuits to auxiliary circuits per Publications EN 60950 and VDE 0805.
Resistance, Impedance	Values from Line to Load Terminal - based on Series Trip Circuit Breaker.

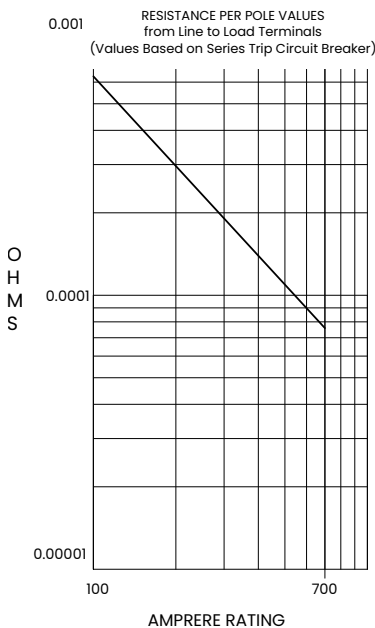

Mechanical

Endurance	4000 ON-OFF operations with rated Current & Voltage & 4000 operations with no load (8000 operations total) @ 5 per minute. Parallel Pole construction: 1000 operations with rated Current and Voltage @ 5 per minute.
Trip Free	All F-Series Circuit Breakers will trip on overload, even when the actuator is forcibly held in the ON position.
Trip Indication	The operating actuator moves positively to the OFF position when an overload causes the circuit breaker to trip.

Physical

Number of Poles	1-3 Poles Note: Ratings over 250 Amps only available with parallel pole.
Internal Circuit Configuration	Series (with or without auxiliary switch), Switch Only (with or without auxiliary switch).
Available Accessories	Factory installed: DC Current Metering Shunt (25 mV @Ir)
Weight	Varies depending on construction. Consult factory.
Standard Colors	Housing - Black; Actuator- Black or White with contrasting ON-OFF legend.

Environmental

Designed and tested in accordance with requirements of specification MIL-PRF-55629 & MIL-STD-202 as follows:

Shock	Withstands 100 Gs, 6ms, sawtooth while carrying rated current per Method 213, Test Condition "I". Instantaneous and ultra-short curves tested @ 90% of rated current.
Vibration	Withstands 0.060" excursion from 10-55 Hz, and 10 Gs 55-500 Hz, at rated current per Method 204C, Test Condition A. Instantaneous and ultrashort curves tested at 90% of rated current.
Moisture Resistance	Method 106D; ten 24-hour cycles @ + 25°C to +65°C, 80-98% RH.56 days @ +85°C, 85% RH.
Salt Spray	Method 101, Condition A (90-95% RH @ 5% NaCl Solution, 96 hrs)
Thermal Shock	Method 107D, Condition A (Five cycles @ -55°C to +25°C to +85°C to +25°C).
Operating Temperature	-40° C to +85° C

Tech Specs

Tables

Table A: Lists UL Listed (489) and CSA Certified (C22.2 NO. 5.1-M) configurations and performance capabilities as a Molded Case Circuit Breaker

UL489 Listed Branch Circuit Breakers						
Circuit Configuration	Voltage			Current Rating	Interrupting Capacity (Amps)	
	Max Rating	Frequency	Phase	Full Load Amps	UL / CSA 1-3 Poles	TUV ² 1 or 2 Poles
Series	125	DC	-	50 - 250	50,000	25,000
	120/240 ¹	50/60	1	100 - 250	10,000	-
	277					
	208Y / 120		3			

Notes:

¹ 120/240V rating available in 2 or 3 poles. In a 3 pole construction the center pole is Neutral.

² TUV constructions are not available with AC ratings and 150-250 amp ratings only.

Table B: Lists UL Listed configurations and performance capabilities as Circuit Breakers for use in Communications Equipment (Guide DITT, File E189195), under UL489A

UL489 Listed Branch Circuit Breakers				
Circuit Configuration	Voltage		Current Rating	Interrupting Capacity (Amps)
	Max Rating	Frequency	Full Load Amps	Without Backup Fuse
Series	125	DC	251 - 700	50,000

Agency Approvals

UL 489 Circuit Breakers , Molded Case
(Guide DIVQ, File E129899)
Complies with the requirements
of the CSA Standard for Molded
Case Circuit Breakers,

UL 489A CANCSA- C22.2 No. 5.1 -M
Circuit Breakers for Use in
Communications Equipment
(Guide DITT, File E189195)

TUV Certified IEC 60947-2
Low Voltage Switchgear and
Control Gear under TUV License
No. R72031058

Time Delay Specs

To view all hydraulic-magnetic circuit breaker time delay values, please visit
www.carlingtech.com/sites/default/files/documents/Carling-HM-CB-Time-Delays.pdf

Ordering Scheme

Sample Part Number **F A 2 - B 0 - 14 - 820 - 1 2 A - B G**

Selection 1 2 3 4 5 6 7 8 9 10 11 12

1. SERIES

F

2. ACTUATOR

A Handle, one per pole
S Mid-Trip Handle, one per pole
T Mid-Trip Handle, one per pole & Alarm Switch

3. POLES

1 One 2 Two 3 Three

4. CIRCUIT ²

A Switch Only (no coil)¹
B Series Trip (current)
C Series Trip (voltage)²
Parallel Pole Construction:
M Series Trip (Current) with Metering Shunt^{3,4}
N Switch Only with Metering Shunt^{3,4}
P Series Trip (Current)³
Q Switch Only³

5 AUXILIARY SWITCH ⁵

0 without Auxiliary Switch
2 S.P.D.T. 0.110 Q.C. Terminals
4 S.P.D.T. 0.110 Q.C. Terminals (Gold Contacts)
5 S.P.S.T., 0.093 Q.C. Terminals (Gold Contacts)
6 S.P.S.T. 0.110 Q.C. Terminals
7 S.P.S.T. 0.110 Q.C. Terminals (Gold Contacts)
8 S.P.S.T. 0.187 Q.C. Terminals
9 S.P.D.T. 0.187 Q.C. Terminals
A S.P.S.T., 0.093 Round QC Terminals⁶
B S.P.D.T., 0.093 Round QC Terminals⁶

6. FREQUENCY & DELAY

03 DC 50/60Hz, Switch Only	16 DC Long
10 DC Instantaneous ⁷	22 AC Short
11 DC Ultra Short	24 AC Medium
12 DC Short	26 AC Long
14 DC Medium	

7. CURRENT RATING (AMPERES) ⁴

CODE	AMPERES				
810	100.00	922	225.00	845	450.00 ⁸
912	125.00	825	250.00	850	500.00 ⁸
815	150.00	830	300.00 ⁸	860	600.00 ⁸
917	175.00	835	350.00 ⁸	870	700.00 ⁸
820	200.00	840	400.00 ⁸		

OR VOLTAGE COIL ⁷

CODE	RATING	TRIP VOLTS				
A06	6DC	5DC	A24	24DC 20DC	A65	65DC 55DC
A12	12DC	10DC	A32	32DC 25DC	J06	6AC 5AC
A18	18DC	15DC	A48	48DC 40DC	B25	120DC 100DC

8. TERMINAL

Back Connected (Front Mounted Only)		Max Rating
1	3/8-16 Stud ⁹	250A
2	3/8-16 Screw, Line & Load ¹⁴	700A
5	3/8-16 Short Stud ¹⁴	250A
Front Connected (Back Mounted Only)¹¹		Max Rating
3	Box Wire Connector, Line & Load	700A
4	3/8-16 Screw, Line & Load ¹⁴	700A

9. ACTUATOR COLOR & LEGEND ^{12,13}

Actuator Color	I-O	ON-OFF	Dual	Marking Color
White	A	B	1	Black
Black	C	D	2	White

10. MOUNTING

Front Mounting Inserts	Back Mounting Inserts
A 10-32	10-32 screw clearance holes
B ISO M5	10-32 screw clearance holes

11. MAXIMUM APPLICATION RATING

	VOLTAGE	CURRENT
B	125 VDC	700A
C ¹⁵	120/240	250A
F	277 VAC	250A
7 ¹⁶	120/208 VAC	250A

12. AGENCY APPROVAL

A No approvals
G UL489 Listed & cULus
J UL489 Listed, cULus & TUV Certified to IEC/EN 60934
T UL489A (Telecom) Listed

Notes:

- For 100 to 250 amps, select Current Code 825. For 300-400 amps, select Current Code 840. For 450-700 amps, select Current Code 870.
- Available with Frequency and Delay code 10 or 20 only, and are not rated for continuous duty. Delay 10 and 20 are only available with voltage coils.
- 3 Codes M, N, P & Q (Parallel Poles) are supplied with factory installed Bus Bar on Line and Load.
- 4 Metering terminals are female pin type, ref. Molex part number 02-09-1101, model 1189-T.
- Auxiliary Switch breakers are only available with Series Trip and Switch Only circuits. On multi-pole breakers, one Auxiliary Switch is supplied, mounted in the extreme right pole per figure A. Back-Mounted breakers require special mounting provisions when an Auxiliary Switch is specified.
- Available with parallel pole construction (circuit codes P and Q, and breakers with circuit codes M and N).
- Frequency and delay code 10 is only available with Voltage Coils. Voltage Coils are not rated for continuous duty.
- Ratings over 250 amps are only available with Agency Approval code T (UL489A) and are Parallel Pole configuration (circuit codes M, N, P and Q). 300-450 amp ratings are available on two pole breakers. 500-700 amp ratings are available on three pole breakers.
- Per UL requirement, an "Anti-Flash Over Barrier" is supplied between poles on multipole breakers with 3/8 - 16 stud terminals (Terminal Code 1) on AC rated breakers only.
- Front connected breakers can also be front mounted by utilizing the supplied front panel mounting inserts. Terminal connections must be made before mounting.
- Box Wire connector will accept #6 through 250 MCM copper wire.
- Agency codes G & T must have ON-OFF or dual legends. Agency code J must have dual legend.
- Other colors available. Consult factory.
- Terminals 2,4 & 5 are shipped without terminal hardware.
- 2 or 3 Pole Circuit Breaker Required for 120/240 VAC Rating.
- 3 Pole Circuit Breaker Required for 120/208 VAC Rating.

[Configure Complete Part Number >](#)

[Browse Standard Parts >](#)

Dimensional Specs

inches [millimeters]

SERIES TRIP BACK CONNECT (STUD TERMINALS SHOWN)

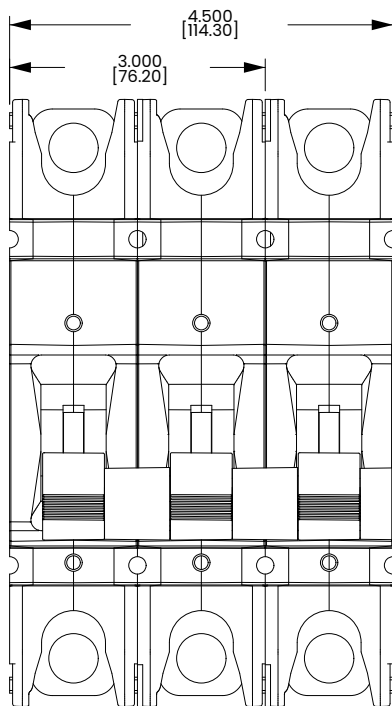
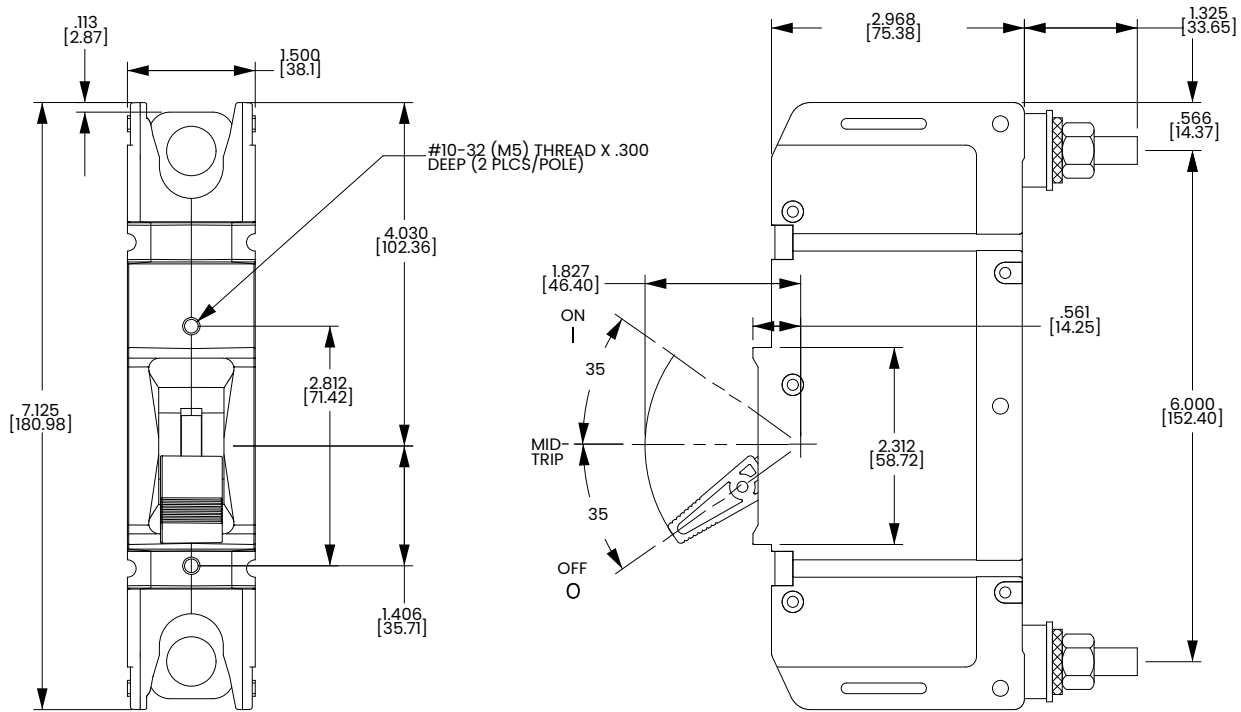

MULTIPOLE SERIES TRIP, SHOWING TERMINAL BARRIER

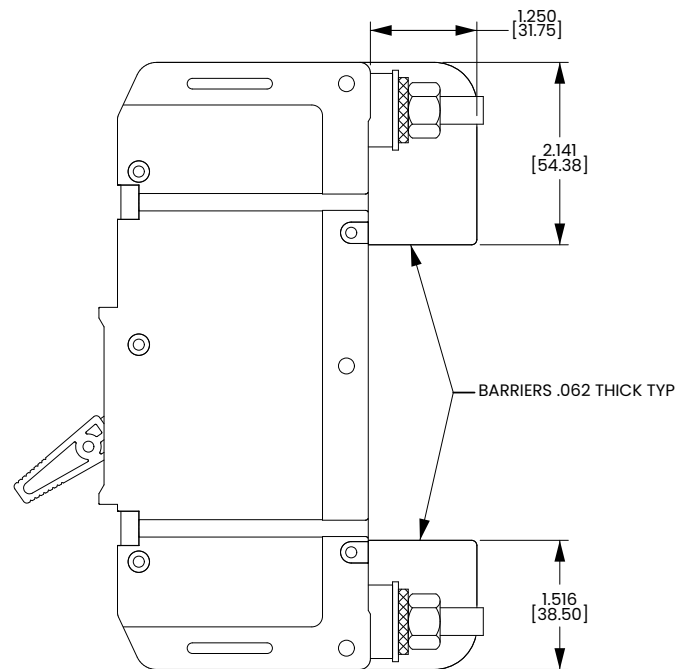

Notes:
1 Tolerance ± 0.020 [.51] unless otherwise specified.

Dimensional Specs

inches [millimeters]

SERIES TRIP FRONT CONNECT (BOX LUG TERMINALS SHOWN)

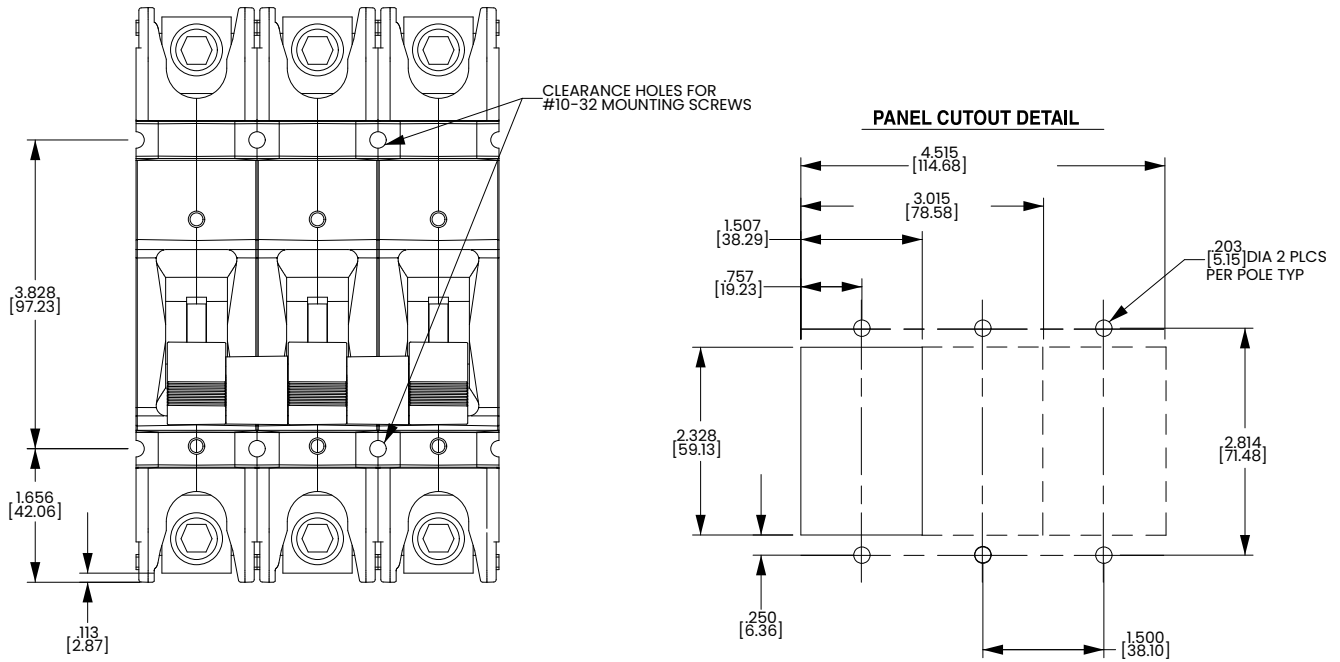

Notes:
1 Tolerance ± 0.020 [.51] unless otherwise specified.

Dimensional Specs

inches [millimeters]

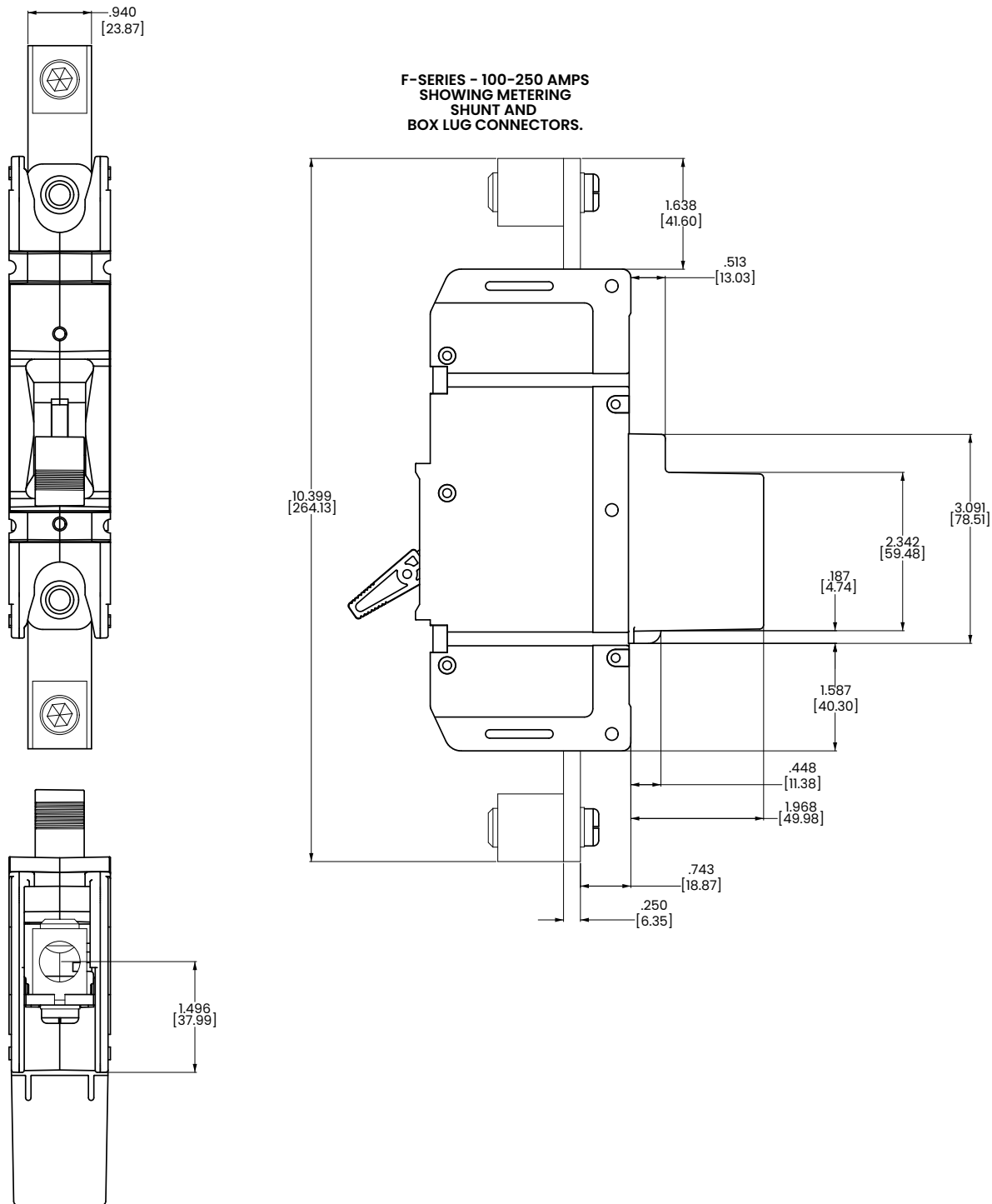

F-Series breakers are available up to 700A, and are also available with a 25 millivolt metering shunt construction. This optional construction provides a safe method for monitoring current flowing through the breaker by simply connecting a meter with light gauge wire to the appropriate terminals located on the shunt housing at the rear of the breaker. You can customize the application by measuring and displaying percentage of current, watts or safe/danger zones.

Notes:
 1 Tolerance ± 0.020 [.51] unless otherwise specified.

Dimensional Specs

inches [millimeters]

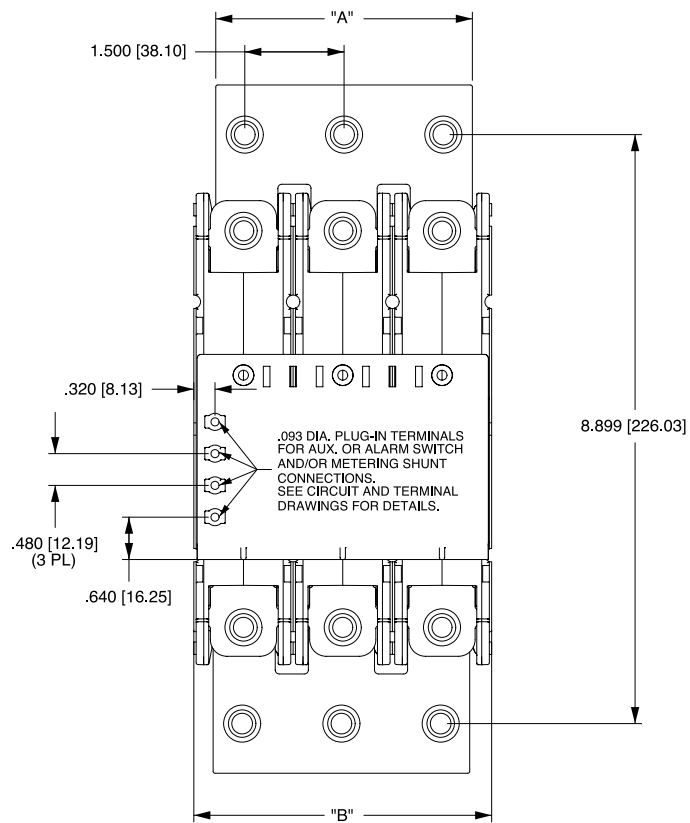
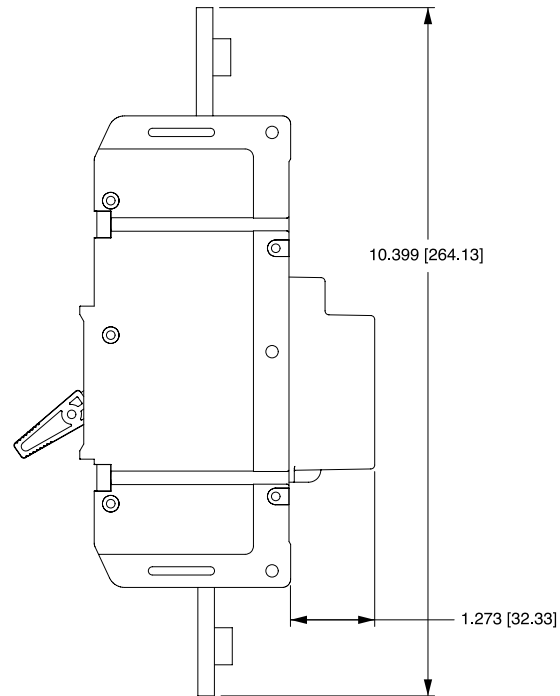

**F-SERIES PARALLEL POLE 250-700 AMPS
SHOWING FRONT CONNECT SCREW TERMINALS**



Notes:

1 Tolerance ± 0.020 [.51] unless otherwise specified.

Circuit & Terminal Diagram

inches [millimeters]

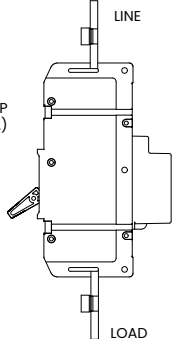
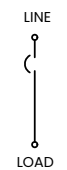
F-SERIES PARALLEL POLE CONSTRUCTION:

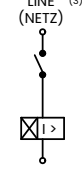
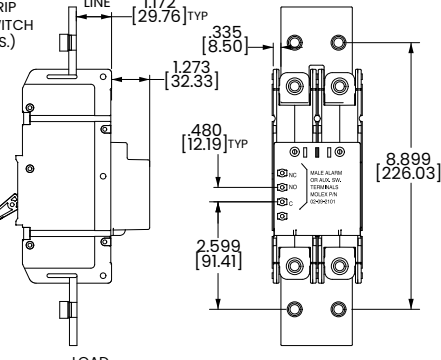
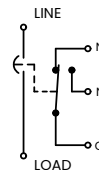
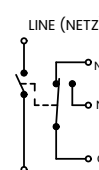
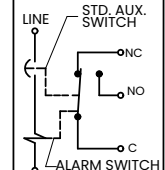
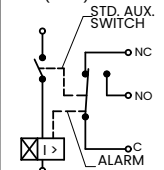
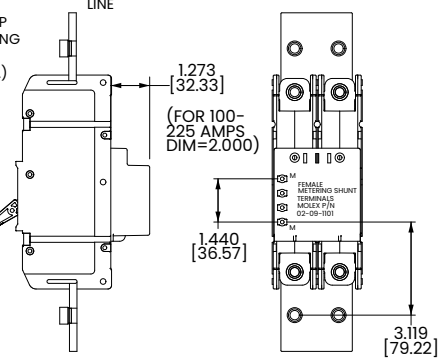
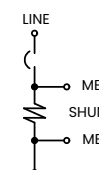
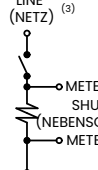
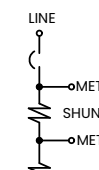
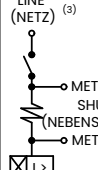
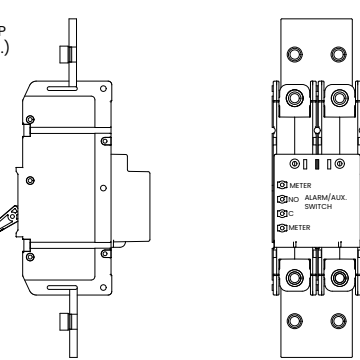
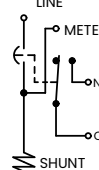
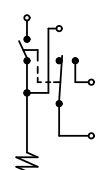
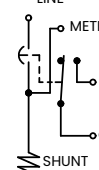
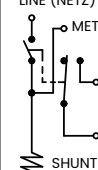
CIRCUIT BREAKER PROFILE	CIRCUIT SCHEMATIC		CIRCUIT CODE	AUX. SWITCH CODE	CIRCUIT SCHEMATIC		CIRCUIT CODE	AUX. SWITCH CODE
	ANSI	IEC			ANSI	IEC		
<p>SERIES TRIP (2 TERM'S.)</p> 	<p>SWITCH ONLY (NO COIL)</p>  		A	0	<p>SERIES TRIP</p>  		BC	0
<p>SERIES TRIP W/AUX. SWITCH (2 TERM'S.)</p> 	<p>SWITCH ONLY (NO COIL) WITH ALARM OR AUX. SWITCH</p>  		A	B	<p>SERIES TRIP WITH AUXILIARY/ ALARM SWITCH</p>  		BC	B
<p>SERIES TRIP W/METERING SHUNT (4 TERM'S.)</p> 	<p>SWITCH ONLY (NO COIL) WITH METERING SHUNT</p>  		N	0	<p>SERIES TRIP CURRENT COIL, WITH METERING SHUNT</p>  		M	0
<p>RELAY TRIP (4 TERM'S.)</p> 	<p>SWITCH ONLY WITH ALARM OR AUX. SWITCH AND METERING SHUNT</p>  		N	A	<p>SERIES TRIP WITH ALARM OR AUX. SWITCH AND METERING SHUNT</p>  		M	A

Notes:
1 Tolerance ±.020 [.51] unless otherwise specified.

Circuit & Terminal Diagram

inches [millimeters]

F-SERIES PARALLEL POLE CONSTRUCTION:

CIRCUIT BREAKER PROFILE	CIRCUIT SCHEMATIC		CIRCUIT CODE	AUX. SWITCH CODE	CIRCUIT SCHEMATIC		CIRCUIT CODE	AUX. SWITCH CODE
	ANSI	IEC			ANSI	IEC		
<p>SERIES TRIP (2 TERM'S.)</p> <p>Dimensions: 2.965 [76.31], 1.328 [33.73], 5.991 [152.17]</p>	SWITCH ONLY (NO COIL)		A	0	SERIES TRIP		BC	0
	ANSI	IEC			ANSI	IEC		
<p>SERIES TRIP W/AUX. SWITCH (5 TERM'S.)</p> <p>Dimensions: 2.733 [69.41], 2.22 [56.63], 2.496 [63.39], 2.091 [53.11]</p>	SWITCH ONLY (NO COIL) WITH AUXILIARY SWITCH		A	2 3 4 5 9	SERIES TRIP WITH AUXILIARY SWITCH		BC	2 3 4 5 9
	ANSI	IEC			ANSI	IEC		

TERMINAL DETAILS BACK CONNECT

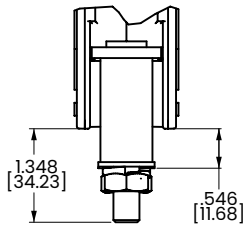

3/8-16 THREADED STUD
CODE 1

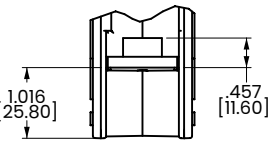
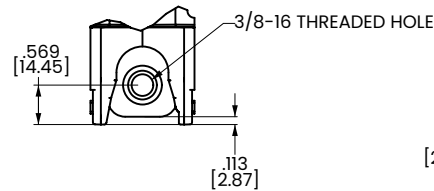

3/8-16 THREADED STUD
CODE 2

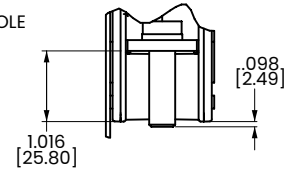

SHORT STUD
CODE 5

FRONT CONNECT

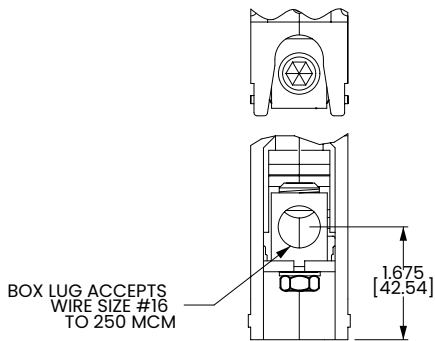

BOX WIRE
CONNECTOR

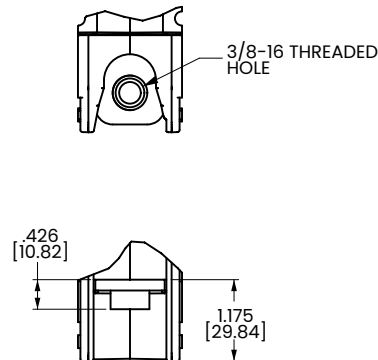

3/8-16 THREADED HOLE
CODE 4

Notes:

1 Tolerance $\pm .020$ [.51] unless otherwise specified.

G-Series

Hydraulic-Magnetic Circuit Breaker

PRODUCT WEBPAGE

request sample, configure part

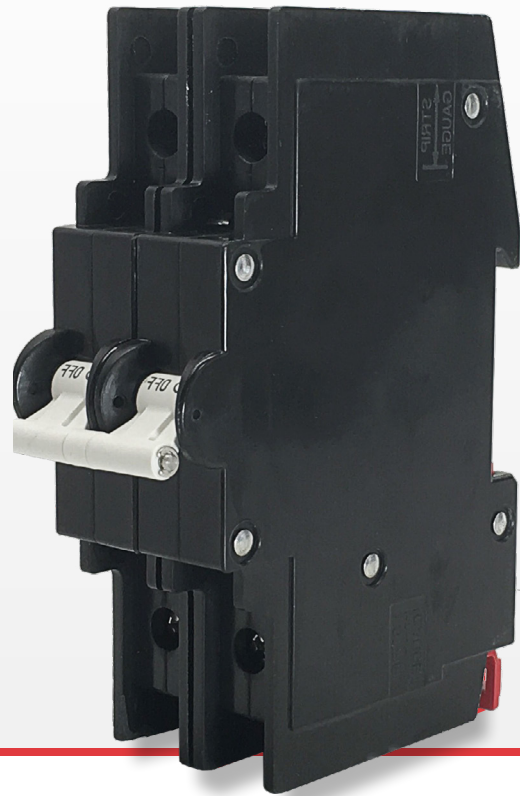

DIN Rail Mounted Circuit Breaker Optional Integrated Auxiliary Switch

Carling's G-Series hydraulic-magnetic circuit breaker combines maximum protection with ease of use. The breakers are DIN rail mount and offer common trip linkage, a unique terminal bus connection system, finger safe terminals and wiping contacts for added longevity. Optional integrated auxiliary switch for breaker status is also available. The G-Series is rated up to 80 amps, 480VAC/80VDC or 50 amps, 240VAC/125VDC for UL 489 and has a max IC of 5,000 amps.

1-4	.2-80	240	125
Poles	Amps	VAC Max	VDC Max

Typical Applications

- Industrial Automation
- Control Panels
- Lighting
- Renewable Energy
- Telecom

Design Features

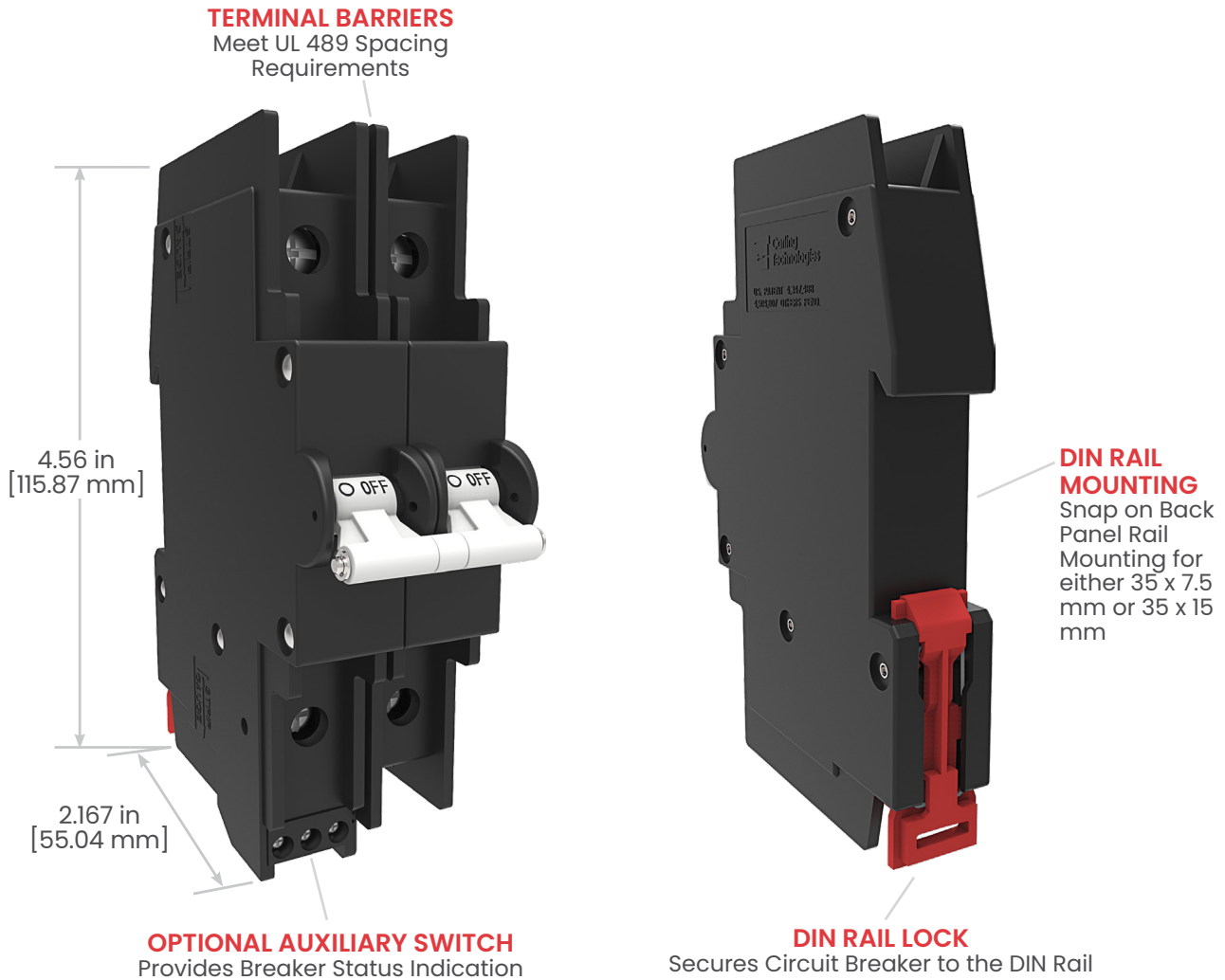

Auxiliary Switch with Internal Connector



Advantages:

- Pre-wiring is possible
- Easy interchangeable
- Time saving solution
- Various connection methods
- Many different plugs

Example Plugs:

Spring clamp terminals

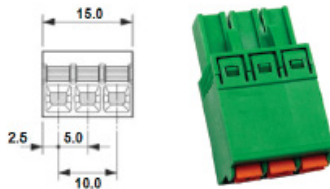

Dimensions in mm

- | | |
|--------------------------------------|-----------------|
| Wire size solid wire | 0.2 - 1.5 mm 2 |
| Wire size stranded wire | 0.2 - 2.5 mm 2 |
| Wire size stranded wire with ferrule | 0.25 - 1.5 mm 2 |
| Wire stripping length | 10 mm |

The auxiliary contact with internal connector can be used with Phoenix Combicon plugs. Phoenix item number internal connector: 1753453. The circuit breaker is standard delivered without plugs.

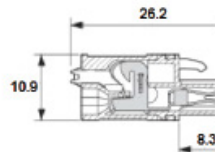

Screw terminals

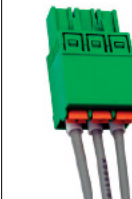

Screw terminals 45° angle

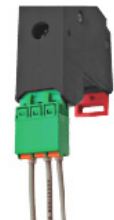

*Manufacturer reserves the right to change product specification without prior notice.

Tech Specs

Electrical

Maximum Voltage	AC: 240VAC (single pole), 480VAC (3 poles, additional pole shall be dedicated for neutral break) DC: 80VDC (single pole & multipole)
Current Ratings	0.2 – 80A. Other ratings available, see Ordering Scheme.
Auxiliary Switch Rating	(optional) Integrated, load side. SPST, 3A – 125VAC, 2A – 30VDC. Auxiliary switch senses the on & off position of circuit breaker handle, as well as contact arm position. Switch connections are screw terminals.
Insulation Resistance	Minimum of 100 Megohms at 500 VDC
Dielectric Strength	UL, CSA: 1960 V 50/60 Hz for one minute between all electrically isolated terminals. G-Series circuit breakers comply with the 8mm spacing and 3750V 50/60 Hz dielectric requirements from hazardous voltage to operator accessible surfaces, between adjacent poles and from main circuits to auxiliary circuits per Publications EN 60950 and VDE 0805.
Resistance, Impedance	Values from Line to Load Terminal -based on series trip circuit breaker.

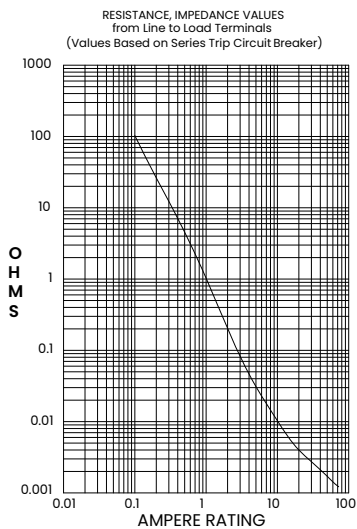

CURRENT (AMPS)	TOLERANCE (%)
0.20 - 5.0	15
5.1 - 20.0	25
20.1 - 80.0	35

Mechanical

Endurance	10,000 ON-OFF operations @ 6 per minute; with rated current & voltage.
Trip Free	All G-Series circuit breakers will trip on overload, even when actuator is forcibly held in the ON position.
Trip Indication	The operating actuator moves positively to the OFF position when an overload causes the breaker to trip. With mid-trip, the handle moves to the mid position on electrical trip of the circuit breaker. With mid trip handle with alarm switch, handle moves to the mid position and the alarm switch actuates when the circuit breaker is electrically tripped.

Physical

Number of Poles	1 pole ≤ 63A, 2 poles ≤ 63A per pole
Weight	Approx. 172 grams/pole (4.13 oz).
Standard Colors	Housing: Black

Environmental

Designed in accordance with requirements of specification MIL-PRF-55629 & MIL-STD-202 as follows:

Shock	Withstands 100 Gs, 6ms sawtooth while carrying rated current per Method 213, Test Condition "1". Instantaneous and ultrashort curves tested @ 90% of rated current.
Vibration	Withstands 0.060" excursion from 10-55 Hz & 10 Gs 55-500 Hz, @ rated current per Method 204C, Test Cond. A. Instantaneous & ultrashort curves tested @ 90% of rated current.
Moisture Resistance	Method 106D, i.e., ten 24-hour cycles @ +25°C to +65°C, 80-98% RH.
Salt Spray	Method 101, Condition A (90-95% RH @ 5% NaCl Solution, 96 hrs).
Thermal Shock	Method 107D, Condition A (five cycles @ -55°C to +25°C to +85°C to +25°C).
Operating Temperature	-40° C to +85° C

Tech Specs

Tables

Table A: Lists UL Recognized, CSA Accepted and TUV Certified capabilities as a Component Supplementary Protector.

Component Supplementary Protectors									
Circuit Configuration	Voltage				Current Rating	Short Circuit Capacity (Amps)		Application Codes	
	Max Rating	Frequency	Phase	Minimum Poles	Full Load Amps	Without Backup Fuse		UL	CSA
						UL/CSA	TUV		
Series	80	DC	---	1	.2 - 80	5000	3000	TCI, OLI, UI	TCI, OLI, UI
	240	50 / 60	1	1	.2 - 63	3000	1500		
	240			2					
	480			3					

Table B: Lists UL Listed (489) configuration and performance capabilities.

UL489 Listed Branch Circuit Breakers						
Circuit Configuration	Voltage				Current Rating	Interrupting Capacity (Amps RMS)
	Max Rating	Frequency	Phase	Poles	Full Load Amps	
Series	80	DC	---	1	1 - 50	5000
	125	DC	---	2	1 - 50	5000
	120	50 / 60	1	1	1 - 50	5000
	120 / 240	50 / 60	1	1 - 3 ¹	1 - 50	5000
	240	50 / 60	1	1	1 - 25	5000

¹ One pole out of the three poles must be a neutral break.

Time Delay Specs

To view all hydraulic-magnetic circuit breaker time delay values, please visit www.carlingtech.com/sites/default/files/documents/Carling-HM-CB-Time-Delays.pdf

Ordering Scheme

UL 1077 Recognized

Sample Part Number

G A 1 - B 0 - 24-650 - 1 1 - D C

Selection 1 2 3 4 5 6 7 8 9 10 11

1. SERIES

G

2. ACTUATOR

A Handle, one per pole
S Mid-Trip Handle, one per pole

3. POLES

1 One 3 Three
2 Two 4 Four

4. CIRCUIT

A Switch Only (no coil) ¹ B Series Trip (current)

5. AUXILIARY/ALARM SWITCH ³

0 without Aux Switch
1 S.P.D.T., Screw Terminal
3 S.P.D.T. Screw Terminal (Gold Contacts)
5 Plug-in Terminal
6 Plug-in Terminal (Gold Contacts)

6. FREQUENCY & DELAY

03 Switch Only	24 50/60 Hz Medium
10 DC, Instantaneous	26 50/60 Hz Long
11 DC, Ultra Short	42 50/60 Hz High-inrush Short ²
12 DC, Short	44 50/60 Hz High-inrush Medium
14 DC, Medium	46 50/60 Hz High-inrush Long
16 DC, Long	52 DC High-inrush Short
20 50/60 Hz Instantaneous	54 DC High-inrush Medium
21 50/60 Ultra Short	56 DC High-inrush Long
22 50/60 Hz Short	

7. CURRENT RATING (AMPERES)

CODE	AMPERES						
220	0.200	415	1.500	485	8.500	624	24.000
225	0.250	517	1.750	490	9.000	625	25.000
230	0.300	420	2.000	495	9.500	630	30.000
235	0.350	522	2.250	610	10.000	635	35.000
240	0.400	425	2.500	710	10.500	640	40.000
245	0.450	527	2.750	611	11.000	650	50.000
250	0.500	430	3.000	711	11.500	655	55.000
255	0.550	435	3.500	612	12.000	660	60.000
260	0.600	440	4.000	712	12.500	663	63.000
265	0.650	445	4.500	613	13.000	665	65.000
270	0.700	450	5.000	614	14.000	670	70.000
275	0.750	455	5.500	615	15.000	672	72.000
280	0.800	460	6.000	616	16.000	673	73.000
285	0.850	465	6.500	617	17.000	675	75.000
290	0.900	470	7.000	618	18.000	680	80.000
410	1.000	475	7.500	620	20.000		
512	1.250	480	8.000	622	22.000		

8. TERMINAL

1 Screw Terminal

9. ACTUATOR COLOR & LEGEND

Actuator Color	I-O	ON-OFF	Dual	Legend Color
White	A	B	1	Black
Black	C	D	2	White
Red	F	G	3	White
Green	H	J	4	White
Blue	K	L	5	White
Yellow	M	N	6	Black
Gray	P	Q	7	Black
Orange	R	S	8	Black

10. APPLICATION RATING ⁹

B 125 VDC ⁵
D 240 VAC
H 480 VAC ⁴
M 80 VDC

11. AGENCY APPROVAL

A Without Approvals
C UL Recognized
E UL Recognized, TUV Certified

Notes:

- Switch only circuit only available when tied to a protected pole (Circuit code B)
 - for 2 to 30 amps select current code 630
 - for 31 to 50 amps select current code 650
 - for 51 to 63 amps select current code 663
 - Use delay 03 for all switch only poles
- Hi Inrush Delays limited to 50A max
- On multi-pole breakers one auxiliary switch is supplied, mounted in the extreme left pole when viewed from front of panel
- 480 VAC rating requires 3 or 4 pole break 3Φ and 2 pole break 1Φ
- This construction is polarity sensitive when constructed as a single pole unit, 125 VDC is only available without agency approvals

[Configure Complete Part Number >](#)

[Browse Standard Parts >](#)

Ordering Scheme

UL 489 Listed

Sample Part Number

G A 1 - B 0 - 24-650 - 1 1 - D G

Selection 1 2 3 4 5 6 7 8 9 10 11

1. SERIES

G

2. ACTUATOR

- A** Handle, one per pole
- S**¹ Mid-Trip Handle, one per pole

3. POLES

- 1** One
- 2** Two
- 3** Three

4. CIRCUIT

B Series Trip (current)

5. AUXILIARY/ALARM SWITCH ³

- 0** without Aux Switch
- 1** S.P.D.T., Screw Terminal
- 3** S.P.D.T. Screw Terminal (Gold Contacts)
- 5** Plug-in Terminal
- 6** Plug-in Terminal (Gold Contacts)

6. FREQUENCY & DELAY

- | | |
|-----------------------------|--|
| 11 DC, Ultra Short | 42 50/60 Hz High-inrush Short ⁴ |
| 12 DC, Short | 44 50/60 Hz High-inrush Medium ⁴ |
| 14 DC, Medium | 46 50/60 Hz High-inrush Long ⁴ |
| 16 DC, Long | 52 DC High-inrush Short ⁴ |
| 21 50/60 Ultra Short | 54 DC High-inrush Medium ⁴ |
| 22 50/60 Hz Short | 56 DC High-inrush Long ⁴ |
| 24 50/60 Hz Medium | |
| 26 50/60 Hz Long | |

7. CURRENT RATING (AMPERES)

CODE	AMPERES				
410	1.000	445	4.500	610	10.000
512	1.250	450	5.000	710	10.500
415	1.500	455	5.500	611	11.000
517	1.750	460	6.000	711	11.500
420	2.000	465	6.500	612	12.000
522	2.250	470	7.000	712	12.500
425	2.500	475	7.500	613	13.000
527	2.750	480	8.000	614	14.000
430	3.000	485	8.500	615	15.000
435	3.500	490	9.000	616	16.000
440	4.000	495	9.500	617	17.000

8. TERMINAL

1 Screw Terminal

9. ACTUATOR COLOR & LEGEND

Actuator Color	ON-OFF	Dual	Legend Color
White	B	1	Black
Black	D	2	White
Red	G	3	White
Green	J	4	White
Blue	L	5	White
Yellow	N	6	Black
Gray	Q	7	Black
Orange	S	8	Black

10. APPLICATION RATING ⁹

- B** 125 VDC ⁵
- C** 120/240 VAC ⁶
- D** 240 VAC ⁷
- K** 120 VAC ⁸
- M** 80 VDC ⁹

11. AGENCY APPROVAL

- A** Without Approvals
- G** UL489 Listed

Notes:

- 1 Mid-trip Handle(s) available at 1 pole unit and 2 pole unit only.
- 2 Third pole of a 3 pole unit is switch only pole.
- 3 On multi-pole breakers one auxiliary switch is supplied, mounted in the extreme left pole when viewed from front of panel.
- 4 Hi Inrush Delays limited to 50A maximum.
- 5 125VDC for 2 pole unit only.
- 6 120/240VAC for 2 pole and 3 pole unit only. Limited to 50A maximum, and third pole of a 3-pole unit is switch only pole.
- 7 240VAC for 1 pole unit only, limited to 25A maximum
- 8 120VAC for 1 pole unit only, limited to 50A maximum.
- 9 80VDC for 1 pole unit only

[Configure Complete Part Number >](#)

[Browse Standard Parts >](#)

Dimensional Specs

UL 1077 Recognized

inches [millimeters]

1 POLE WITHOUT AUXILIARY SWITCH

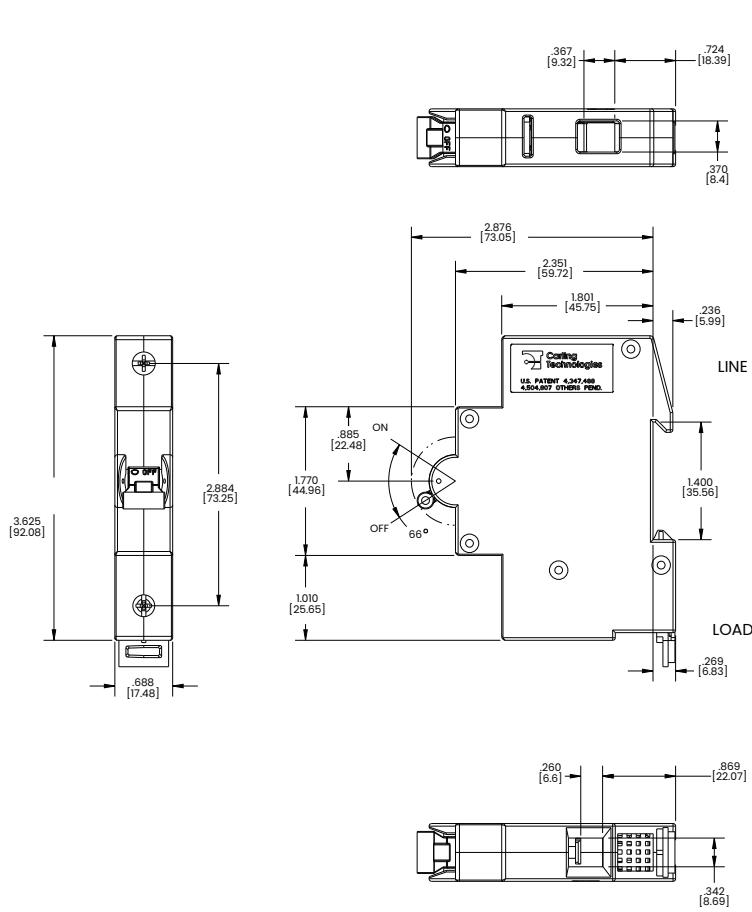

1 POLE WITH AUXILIARY SWITCH (PLUG-IN TERMINAL BLOCK)

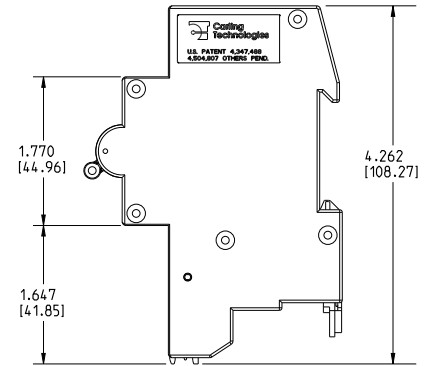

1 POLE WITH AUXILIARY SWITCH (SCREW TERMINAL BLOCK)

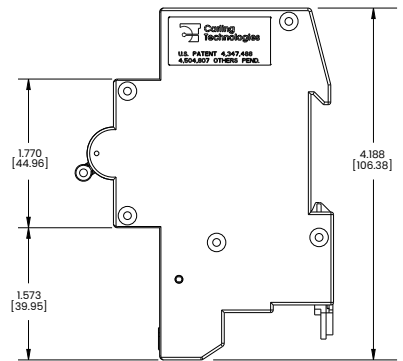

MULTIPLE POLES WITH AUXILIARY SWITCH (PLUG-IN TERMINAL BLOCK)

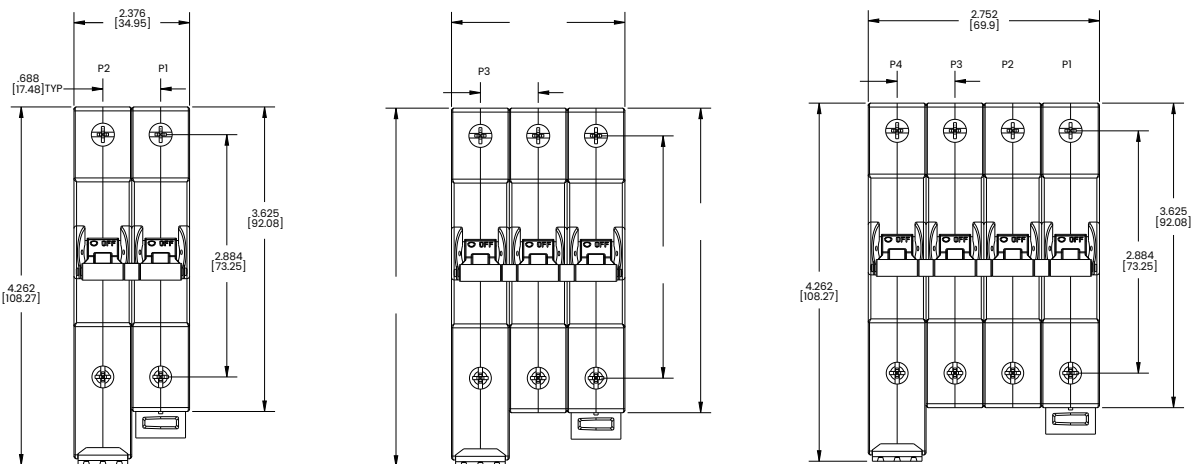

Notes:

- 1 Tolerance ± 0.020 [.51] unless otherwise specified.

Dimensional Specs

inches [millimeters]

UL 489 Listed

1 POLE WITHOUT AUXILIARY SWITCH

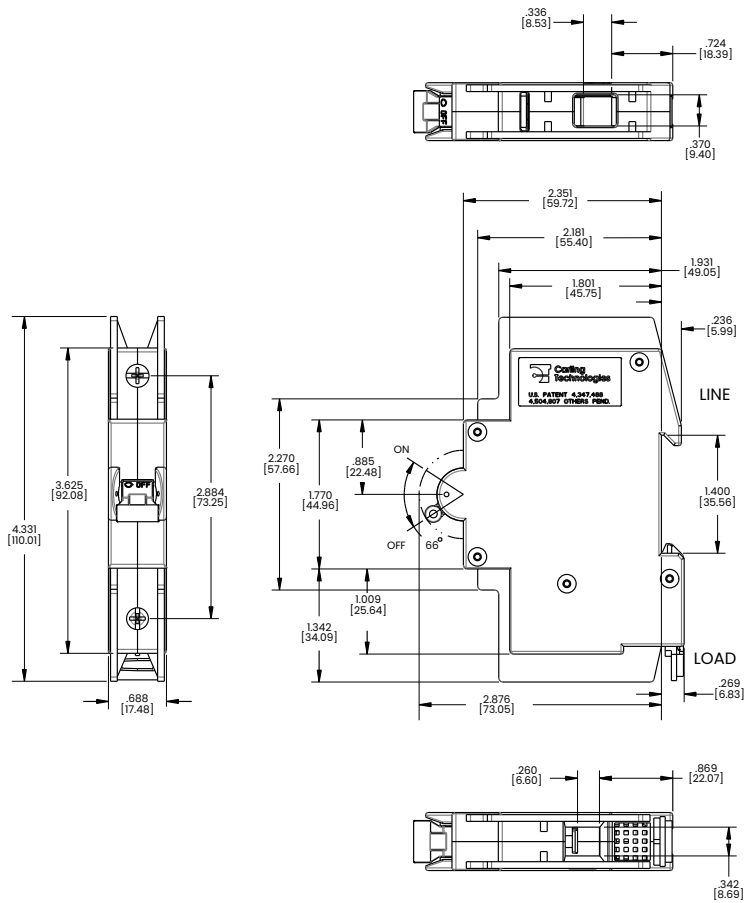

1 POLE WITH AUXILIARY SWITCH (PENDING) (PLUG-IN TERMINAL BLOCK)

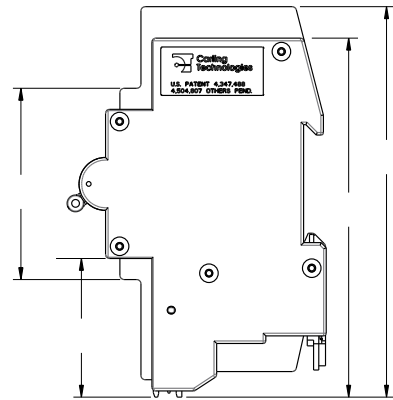

1 POLE WITH AUXILIARY SWITCH (PENDING) (SCREW TERMINAL BLOCK)

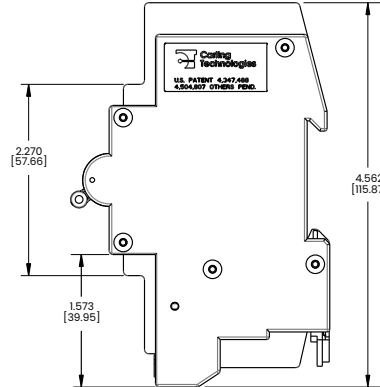

MULTIPLE POLES WITH AUXILIARY SWITCH (PENDING) (PLUG-IN TERMINAL BLOCK)

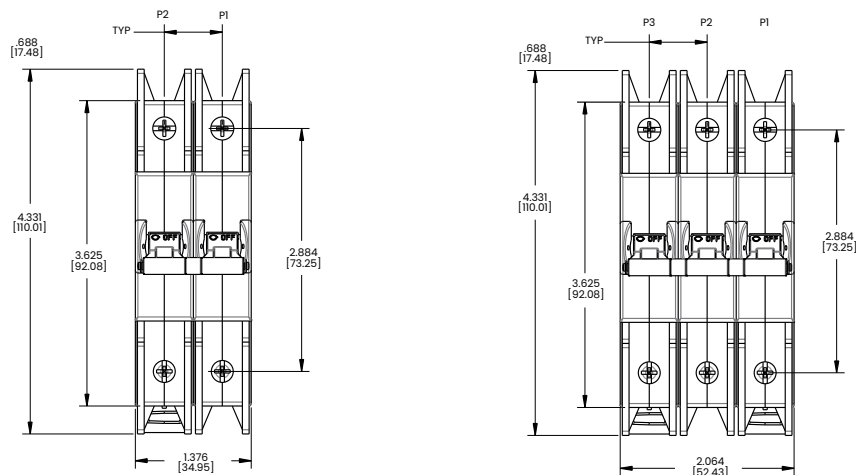

Notes:

- 1 Tolerance ± 0.020 [0.51] unless otherwise specified.

inches [millimeters]

UL RECOGNIZED

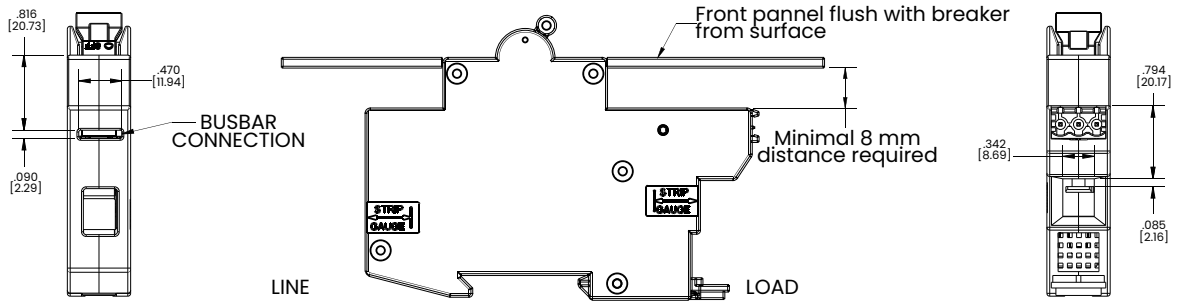

UL489

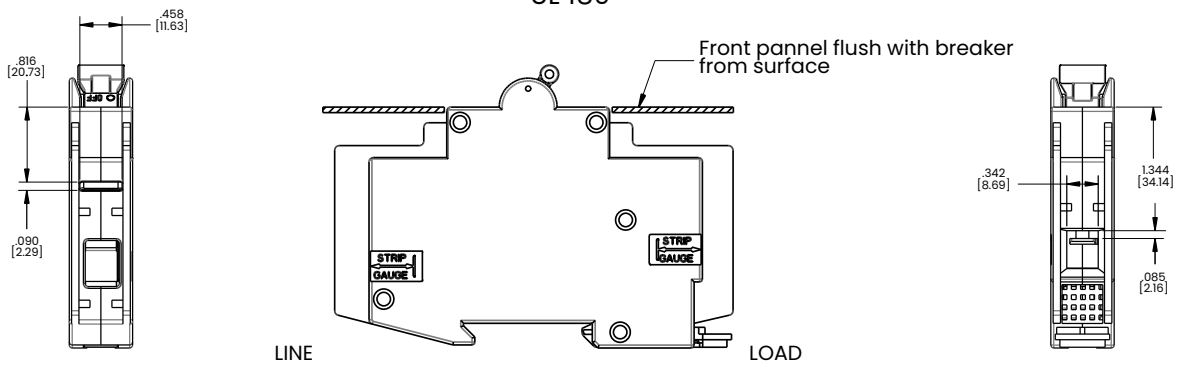

H-Series

Hydraulic-Magnetic Circuit Breaker

[PRODUCT WEBPAGE](#)

request sample, configure part



Compact and IEC Compliant for Global Markets

The H-Series is a compact hydraulic-magnetic circuit breaker, meeting IEC spacing requirements for global market applications. It features a “trip free” mechanism, which will open the contacts when a fault condition occurs, even if the handle is held in the ON position. It fits both general and full amp load conditions, offering a choice of terminal options and handle or rocker actuators. The H-Series is rated up to 35 amps with a maximum voltage of 250VAC/65VDC or 80VDC for single pole configurations and a max IC of 3,000 amps.

1-3	1-35	80	250
Poles	Amps	VDC Max	VAC Max

Typical Applications

- Datacom/Telecom
- Marine
- Medical Equipment

Tech Specs

Electrical

Maximum Voltage	250VAC 50/60Hz 80 VDC
Current Ratings	Standard current coils: 1.00, 2.50, 5.00, 7.50, 10.0, 15.0, 20.0, 25.0, 30.0, 32.0, 35.0 SPDT: 10.1A-250VAC, Auxiliary Switch Rating 1.0A-65VDC/0.5A-80VDC,
Auxiliary Switch Rating	1.0A-65VDC/0.5A-80VDC, 0.1A-125VAC (with gold contacts)

Mechanical

Endurance	10,000 ON-OFF operations @ 6 per minute; with rated current & voltage
-----------	---

Physical

Number of poles	1-3
Weights	Approx. 48 grams/pole (1.7 oz)
Internal Circuit config.	Series and Switch Only (with or without auxiliary switch)

Agency Approvals

UL Recognized under the Component Recognition Program as Protectors, Supplementary (Guide QVNU2 File E75596)
UL standard 1077

CCC certified, Certificate No. 2010010307447291

CSA Accepted Supplementary Protector
CSA standard C22.2 No. 235

TUV certified to EN60934, Certificate No. R50204086

Typical Protector Resistance

DCR and Impedance values are based on measurements by the voltmeter ammeter method. Rated current is applied for one hour at a voltage not less than 20 volts. Ambient temperature: 25°C; Tolerance: Below 10 amps +/- 25% Above 10 amps +/- 35%

Impedance Chart

Current Rating (Amps)	Series	
	DC-Ohms	50/60Hz-Ohms
1	0.85	0.87
2.5	0.13	0.15
5	0.035	0.036
7.5	0.018	0.019
10	0.010	0.011
15	0.006	0.0061
20	0.005	0.0051
25	0.003	0.0035
30	0.0025	0.0026
35	0.0021	0.0022

Tables

Table A: Lists UL Recognized, CSA Accepted and TUV Certified configurations and performance capabilities as a Component Supplementary Protector.

Component Supplementary Protectors										
Circuit Configuration	Voltage			Current Rating		Short Circuit Capacity (Amps)			Application Codes	
	Max Rating	Frequency	Phase	Full Load Amps	Minimum Poles	UL	CSA	TUV	UL	CSA
						Without Backup Fuse	Without Backup Fuse	(Icn) Without Backup Fuse		
Series	65	DC	---	1 - 25	1	3000	3000	3000	TC1, OL1, U1	TC1, OL1, U1
	65	DC	---	26 - 35	1	3000	3000	3000	TC1, OL1, U3	TC1, OL1, U3
	80	DC	---	1 - 25	1	1000	1000	1000	TC1, OL1, U1	TC1, OL1, U1
	80 ¹	DC	---	26 - 35	1	1000	1000	1000	TC1, OL1, U3	TC1, OL1, U3
	250	50 / 60	1	1 - 35	1	1500	1500	500	TC1, OL1, U1	TC1, OL1, U3
	250	50 / 60	1	1 - 35	2	1500	1500	500	TC1, OL1, U3	TC1, OL1, U3
	250	50 / 60	3	1 - 35	3	1500	1500	500	TC1, OL0, U3	TC1, OL0, U3

Notes:
1 Polarity Sensitive

Time Delay Specs

To view all hydraulic-magnetic circuit breaker time delay values, please visit www.carlingtech.com/sites/default/files/documents/Carling-HM-CB-Time-Delays.pdf

Ordering Scheme

Handle

Sample Part Number

H A 3 - B 0 - 24 - 420 - 1 B 1 - D C

Selection 1 2 3 4 5 6 7 8 9 10 11 12

1. SERIES

H

2. ACTUATOR 1

- A Handle, one per pole
- B Handle, one per unit

3. POLES 2

- 1 One
- 2 Two
- 3 Three

4. CIRCUIT

- A Switch Only (no coil)
- B Series Trip (current)
- C⁴ Series Trip (voltage)
- G⁴ Relay Trip (voltage)

5. AUXILIARY/ALARM SWITCH 3

- 0 without Aux Switch
- 1³ 0.110 Q.C. term
- 2³ 0.110 Solder Lug
- 3³ 0.110 Q.C. term
- 4³ 0.110 PC term

6. FREQUENCY & DELAY

- 03³ DC 50/60HZ, Switch Only
- 10 DC, Instantaneous
- 11 DC, Ultra Short
- 12 DC, Short
- 14 DC, Medium
- 16 DC, Long
- 20 50/60 Hz Instantaneous
- 21 50/60 Hz Ultra Short
- 22 50/60 Hz Short
- 24 50/60 Hz Medium
- 26 50/60 Hz Long
- 30 DC, 50/60Hz, Instantaneous
- 31 DC, 50/60Hz, Ultra Short
- 32 DC, 50/60Hz, Short
- 34 DC, 50/60Hz, Medium
- 36 DC, 50/60Hz, Long
- 42⁴ 50/60 Hz High-inrush Short
- 44⁴ 50/60 Hz High-inrush Medium
- 46⁴ 50/60 Hz High-inrush Long
- 52⁴ DC High-inrush Short
- 54⁴ DC High-inrush Medium
- 56⁴ DC High-inrush Long

7. CURRENT RATING (AMPERES)

CODE	AMPERES	
410	1.00	445 4.50
512	1.25	450 5.00
415	1.50	455 5.50
517	1.75	460 6.00
420	2.00	465 6.50
522	2.25	470 7.00
425	2.50	475 7.50
527	2.75	480 8.00
430	3.00	485 8.50
435	3.50	490 9.00
440	4.00	495 9.50
610	10.00	710 10.50
618	18.00	711 11.50
620	20.00	712 12.00
622	22.00	713 13.00
624	24.00	714 14.00
625	25.00	715 15.00
630	30.00	716 16.00
632	32.00	717 17.00
635	35.00	

VOLTAGE RATING

CODE	RATING	TRIP VOLTS
A06	6DC	5DC
A12	12DC	10DC
A18	18DC	15DC
A24	24DC	20DC
A32	32DC	25DC
A48	48DC	40DC
A65	65DC	55DC
J06	6AC	5AC
J12	12AC	10AC
J18	18AC	15AC
J24	24AC	20AC
J48	48AC	40AC
J65	65AC	55AC
K20	120AC	65AC
L40	240AC	130AC
B10	110DC	59DC
B20	120DC	65DC

8. TERMINAL

- 1 Push ON 0.250 Tab (Q.C.)
- 2 Screw 8-32 with upturned lugs
- 3 Screw 8-32 (bus type)
- A Screw M4 with upturned lugs
- B Screw M4 (bus type)
- Printed Circuitboard Terminals**
- L 90 Facing Left
- R 90 Facing Right
- S Straight
- T Straight, Long

9. ACTUATOR COLOR & LEGEND

Actuator Color	I-O	ON-OFF	Dual	Legend Color
White	A	B	1	Black
Black	C	D	2	White
Red	F	G	3	White
Green	H	J	4	White
Blue	K	L	5	White
Yellow	M	N	6	Black
Gray	P	Q	7	Black
Orange	R	S	8	Black

10. MOUNTING / BARRIERS

	MOUNTING STYLE	BARRIERS	BEZEL
	Threaded Insert		
1	6-32 x 0.195 inches	no	domed
A	6-32 x 0.195 inches	yes	domed
2	ISO M3 x 5mm	no	domed
B	ISO M3 x 5mm	yes	domed
3	6-32 x 0.195 inches	no	flat
C	6-32 x 0.195 inches	yes	flat
4	ISO M3 x 5mm	no	flat
D	ISO M3 x 5mm	yes	flat

11. MAX. APPLICATION RATING

- A 65VDC
- D 250VAC
- M⁶ 80VDC
- 4⁷ 80VDC / 250VAC

12. AGENCY APPROVAL

- A Without approvals
- C UL Recognized, CSA Accepted
- E UL Recognized, CSA Accepted, TUV Certified
- 5 UL Recognized, CSA Accepted, TUV Certified, CCC Certified

Notes:

- 1 Actuator Option A: handle tie pin, spacer & retainers provided unassembled on multipole units.
Actuator Option B: Handle location as viewed from front of panel: 2 pole: left pole;
3 pole: center pole
- 2 Standard multipole units have all poles identical, except when specifying auxiliary switch
- 3 Auxiliary switch available on Series Trip and Switch Only circuits to 32A. On multipole units, only one auxiliary switch is normally supplied, mounted in extreme right pole.
- 4 Separate Pole Type Voltage Coils not rated for continuous duty. Available only with delay code 10 & 20. Only Available with Agency code C.
- 5 For other current ratings, consult factory.
- 6 26-35A Polarity sensitive, only available as 1 pole unit.
- 7 Voltage code 4 available to 25A max.

[Configure Complete Part Number >](#)

[Browse Standard Parts >](#)

Dimensional Specs

Handle

inches [millimeters]

**1-POLE
(HA1)**

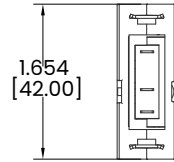
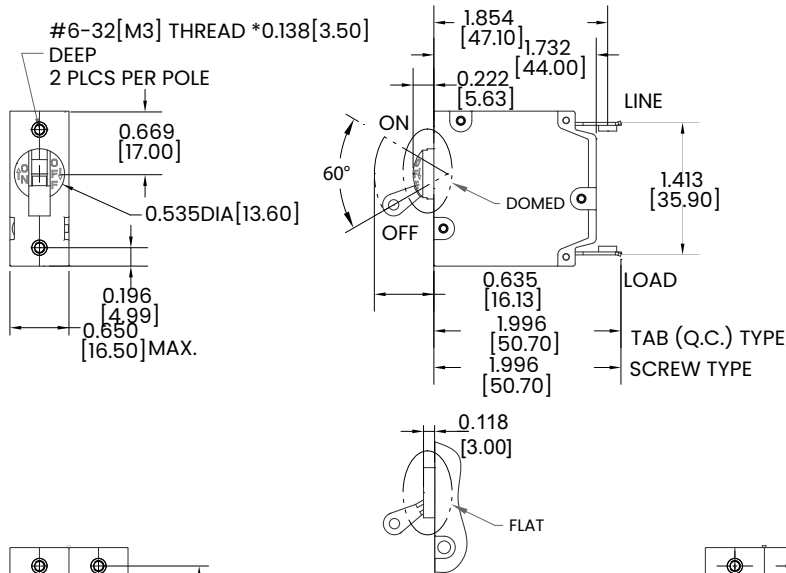

SCREW TYPE TERMINALS IN SERIES TRIP CIRCUIT CONFIGURATION SHOWN. FOR OTHER CONFIGURATIONS, SEE CIRCUIT AND TERMINAL DIAGRAMS.

**2-POLE
(HA2)**

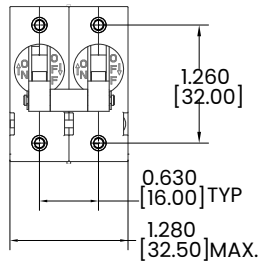

**2-POLE
(HB2)**

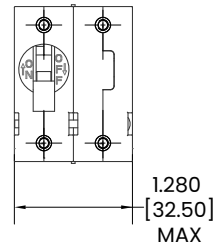

**3-POLE
(HA3)**

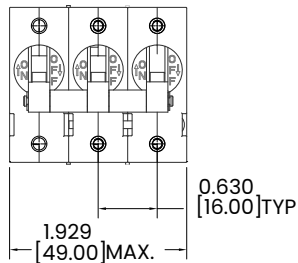

**3-POLE
(HB3)**

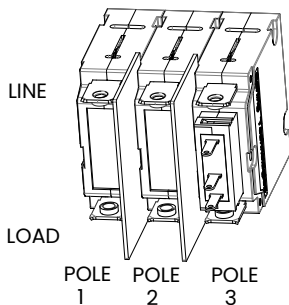
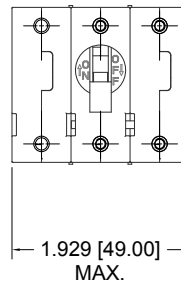

MULTI-POLE IDENTIFICATION SCHEME AS VIEWED FROM TERMINAL END OF BREAKER.

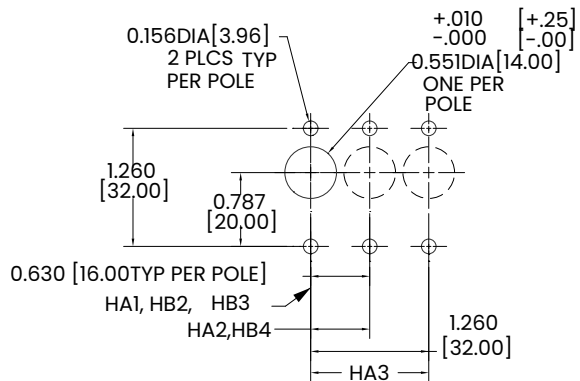

PANEL CUTOUT DETAIL
TOLERANCES ±.005
[±.12]
UNLESS OTHERWISE SPECIFIED

Notes:

1 Tolerance ±.020 [.51] unless otherwise specified.

PC Terminal Diagrams

Handle

inches [millimeters]

PRINTED CIRCUIT BOARD MOUNTING TERMINAL CODE R

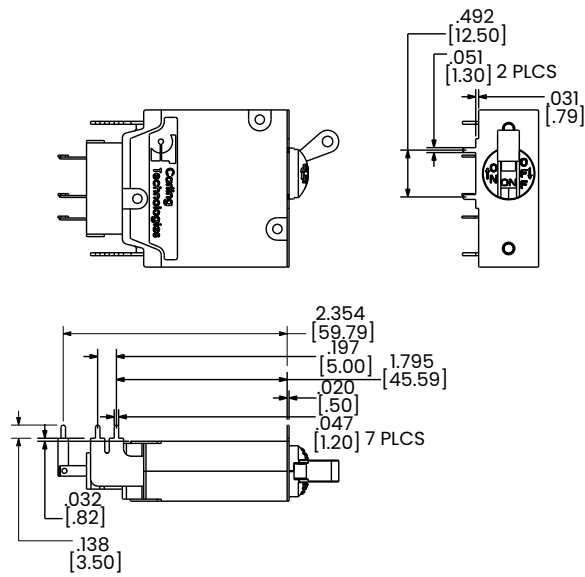

PRINTED CIRCUIT BOARD MOUNTING TERMINAL CODE L

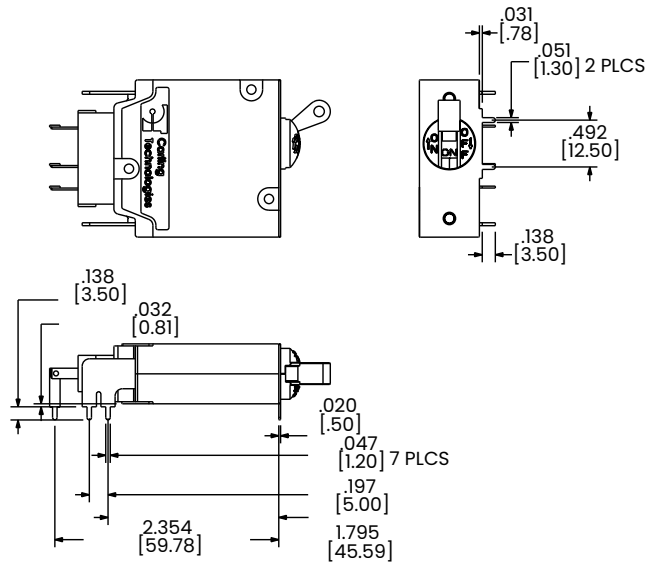

PRINTED CIRCUIT BOARD MOUNTING TERMINAL CODE S & T

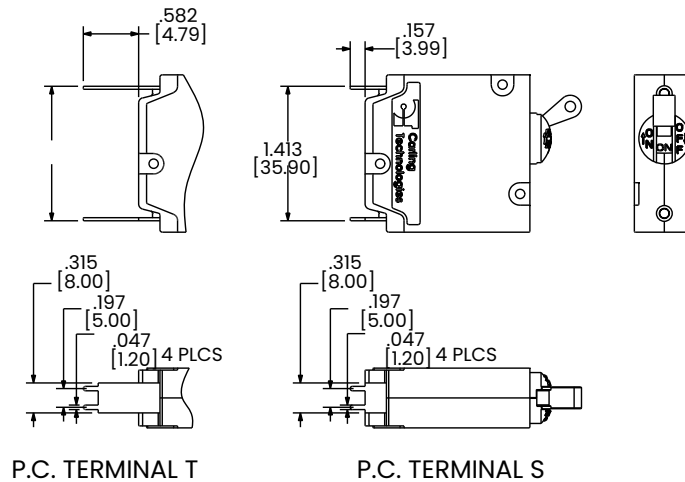

Notes:

1 Tolerance ± 0.020 [.51] unless otherwise specified.

Ordering Scheme

Curved Rocker

Sample Part Number

H J 3 - B 0 - 10 - 450 - 1 B 1 - A C

Selection 1 2 3 4 5 6 7 8 9 10 11 12

1. SERIES

H

2. ACTUATOR ¹

J Vertical - Indicator OFF
K Vertical - Indicator ON
L Horizontal - Indicator OFF
M Horizontal - Indicator ON

3. POLES ²

1 One 2 Two 3 Three

4. CIRCUIT

A Switch Only (no coil) **C**⁴ Series Trip (voltage)
B Series Trip (current) **G**⁴ Relay Trip (voltage)

5. AUXILIARY/ALARM SWITCH

0 without Aux Switch **3**³ 0.110 Q.C. term
1³ 0.110 Q.C. term with gold contacts
2³ 0.110 Solder Lug **4**³ 0.110 PC term

6. FREQUENCY & DELAY

03 ³ DC 50/60HZ, Switch Only	31 DC, 50/60Hz, Ultra Short
10 DC, Instantaneous	32 DC, 50/60Hz, Short
11 DC, Ultra Short	34 DC, 50/60Hz, Medium
12 DC, Short	36 DC, 50/60Hz, Long
14 DC, Medium	42 ⁴ 50/60 Hz High-inrush Short
16 DC, Long	44 ⁴ 50/60 Hz High-inrush Medium
20 50/60 Hz Instantaneous	46 ⁴ 50/60 Hz High-inrush Long
21 50/60 Ultra Short	52 ⁴ DC High-inrush Short
22 50/60 Hz Short	54 ⁴ DC High-inrush Medium
24 50/60 Hz Medium	56 ⁴ DC High-inrush Long
26 50/60 Hz Long	
30 DC, 50/60Hz, Instantaneous	

7. CURRENT RATING (AMPERES)

CODE	AMPERES						
410	1.00	445	4.50	610	10.00	618	18.00
512	1.25	450	5.00	710	10.50	620	20.00
415	1.50	455	5.50	611	11.00	622	22.00
517	1.75	460	6.00	711	11.50	624	24.00
420	2.00	465	6.50	612	12.00	625	25.00
522	2.25	470	7.00	712	12.50	630	30.00
425	2.50	475	7.50	613	13.00	632	32.00
527	2.75	480	8.00	614	14.00	635	35.00
430	3.00	485	8.50	615	15.00		
435	3.50	490	9.00	616	16.00		
440	4.00	495	9.50	617	17.00		

VOLTAGE RATING

CODE	RATING	TRIP VOLTS						
A06	6DC	5DC	A65	65DC	55DC	J65	65AC	55AC
A12	12DC	10DC	J06	6AC	5AC	K20	120AC	65AC
A18	18DC	15DC	J12	12AC	10AC	L40	240AC	130AC
A24	24DC	20DC	J18	18AC	15AC	B10	110DC	59DC
A32	32DC	25DC	J24	24AC	20AC	B20	120DC	65DC
A48	48DC	40DC	J48	48AC	40AC			

Notes:

- Half guard construction have OFF protection for actuator
- Standard multipole units have all poles identical, except when specifying auxiliary switch
- Auxiliary switch available on Series Trip and Switch Only circuits to 32A. On multipole units, only one auxiliary switch is normally supplied, mounted in extreme right pole.
- Separate Pole Type Voltage Coils not rated for continuous duty. Available only with delay code 10 & 20. Only Available with Agency code C.
- For other current ratings, consult factory.
- On Visi-Rocker, Visi portion of rocker cannot be the same color as the bezel. Remainder of rocker same color as bezel.
- 26-35A Polarity sensitive, only available as 1 pole unit.
- Voltage code 4 available to 25A max.

8. TERMINAL

1 Push ON 0.250 Tab (Q.C.)
2 Screw 8-32 with upturned lugs
3 Screw 8-32 (bus type)
A Screw M4 with upturned lugs
B Screw M4 (bus type)
Printed Circuitboard Terminals
L 90 Facing Left
R 90 Facing Right
S Straight
T Straight, Long

9. ACTUATOR COLOR & LEGEND

Actuator Color	I-O	ON-OFF	Dual	Legend Color
White	A	B	1	Black
Black	C	D	2	White
Red	F	G	3	White
Green	H	J	4	White
Blue	K	L	5	White
Yellow	M	N	6	Black
Gray	P	Q	7	Black
Orange	R	S	8	Black

10. MOUNTING / BARRIERS

	MOUNTING STYLE	BARRIERS	PUSH-TO-RESET	BRACKET COLOR
Threaded Insert				
1	6-32 x 0.195 inches	no	no	Black
A	6-32 x 0.195 inches	yes	no	Black
2	ISO M3 x 5mm	no	no	Black
B	ISO M3 x 5mm	yes	no	Black
3	6-32 x 0.195 inches	no	yes	Black
4	6-32 x 0.195 inches	yes	yes	Black
C	ISO M3 x 5mm	no	yes	Black
D	ISO M3 x 5mm	yes	yes	Black
5	6-32 x 0.195 inches	no	no	White
E	6-32 x 0.195 inches	yes	no	White
6	ISO M3 x 5mm	no	no	White
F	ISO M3 x 5mm	yes	no	White
7	6-32 x 0.195 inches	no	yes	White
G	6-32 x 0.195 inches	yes	yes	White
8	ISO M3 x 5mm	no	yes	White
H	ISO M3 x 5mm	yes	yes	White
9	6-32 x 0.195 inches	no	no	Gray
J	6-32 x 0.195 inches	yes	no	Gray
P	ISO M3 x 5mm	no	no	Gray
K	ISO M3 x 5mm	yes	no	Gray
Q	6-32 x 0.195 inches	no	yes	Gray
L	6-32 x 0.195 inches	yes	yes	Gray
U	ISO M3 x 5mm	no	yes	Gray
M	ISO M3 x 5mm	yes	yes	Gray

11. MAX. APPLICATION RATING

A 65VDC
D 250VAC
M⁷ 80VDC
4⁸ 80VDC / 250VAC

12. AGENCY APPROVAL

A Without approvals
C UL Recognized, CSA Accepted
E UL Recognized, CSA Accepted, TUV Certified
5 UL Recognized, CSA Accepted, TUV Certified, CCC Certified

Configure Complete Part Number >

Browse Standard Parts >

Ordering Scheme

Flat Rocker

Sample Part Number

H 3 3 - B 0 - 10 - 450 - 1 B 1 - A C

Selection 1 2 3 4 5 6 7 8 9 10 11 12

1. SERIES

H

2. ACTUATOR ¹

- 3 Single Color Vertical
- 4 Single Color Horizontal
- 7 Push-to-Reset, Single Color Vertical
- 8 Push-to-Reset, Single Color Horizontal

3. POLES ²

1 One 2 Two 3 Three

4. CIRCUIT

- A Switch Only (no coil) C⁴ Series Trip (voltage)
- B Series Trip (current) G⁴ Relay Trip (voltage)

5. AUXILIARY/ALARM SWITCH

- 0 without Aux Switch 3³ 0.110 Q.C. term
- 1³ 0.110 Q.C. term with gold contacts
- 2³ 0.110 Solder Lug 4³ 0.110 PC term

6. FREQUENCY & DELAY

- | | |
|---|---|
| 03 ³ DC 50/60HZ, Switch Only | 31 DC, 50/60Hz, Ultra Short |
| 10 DC, Instantaneous | 32 DC, 50/60Hz, Short |
| 11 DC, Ultra Short | 34 DC, 50/60Hz, Medium |
| 12 DC, Short | 36 DC, 50/60Hz, Long |
| 14 DC, Medium | 42 ⁴ 50/60 Hz High-inrush Short |
| 16 DC, Long | 44 ⁴ 50/60 Hz High-inrush Medium |
| 20 50/60 Hz Instantaneous | 46 ⁴ 50/60 Hz High-inrush Long |
| 21 50/60 Ultra Short | 52 ⁴ DC High-inrush Short |
| 22 50/60 Hz Short | 54 ⁴ DC High-inrush Medium |
| 24 50/60 Hz Medium | 56 ⁴ DC High-inrush Long |
| 26 50/60 Hz Long | |
| 30 DC, 50/60Hz, Instantaneous | |

7. CURRENT RATING (AMPERES)

CODE	AMPERES							
410	1.00	445	4.50	610	10.00	618	18.00	
512	1.25	450	5.00	710	10.50	620	20.00	
415	1.50	455	5.50	611	11.00	622	22.00	
517	1.75	460	6.00	711	11.50	624	24.00	
420	2.00	465	6.50	612	12.00	625	25.00	
522	2.25	470	7.00	712	12.50	630	30.00	
425	2.50	475	7.50	613	13.00	632	32.00	
527	2.75	480	8.00	614	14.00	635	35.00	
430	3.00	485	8.50	615	15.00			
435	3.50	490	9.00	616	16.00			
440	4.00	495	9.50	617	17.00			

VOLTAGE RATING

CODE	RATING	TRIP VOLTS						
A06	6DC	5DC	A65	65DC	55DC	J65	65AC	55AC
A12	12DC	10DC	J06	6AC	5AC	K20	120AC	65AC
A18	18DC	15DC	J12	12AC	10AC	L40	240AC	130AC
A24	24DC	20DC	J18	18AC	15AC	B10	110DC	59DC
A32	32DC	25DC	J24	24AC	20AC	B20	120DC	65DC
A48	48DC	40DC	J48	48AC	40AC	X01	65AC	special catalog #

Notes:

- 1 Push-To-Reset actuator shave OFF portion of rocker shrouded
- 2 Standard multipole units have all poles identical, except when specifying auxiliary switch
- 3 Auxiliary switch available on Series Trip and Switch Only circuits to 32A. On multipole units, only one auxiliary switch is normally supplied, mounted in extreme right pole
- 4 Separate Pole Type Voltage Coils not rated for continuous duty. Available only with delay code 10 & 20. Only Available with Agency code C.
- 5 For other current ratings, consult factory.
- 6 On Visi-Rocker, Visi portion of rocker cannot be the same color as the bezel. Remainder of rocker same color as bezel.
- 7 26-35A Polarity sensitive, only available as 1 pole unit.
- 8 Voltage code 4 available to 25A max.

8. TERMINAL

- 1 Push ON 0.250 Tab (Q.C.)
 - 2 Screw 8-32 with upturned lugs
 - 3 Screw 8-32 (bus type)
 - A Screw M4 with upturned lugs
 - B Screw M4 (bus type)
- Printed Circuitboard Terminals**
- L 90 Facing Left
 - R 90 Facing Right
 - S Straight
 - T Straight, Long

9. ACTUATOR COLOR & LEGEND

Actuator Color	I-O	ON-OFF	Dual	Legend Color
White	A	B	1	Black
Black	C	D	2	White
Red	F	G	3	White
Green	H	J	4	White
Blue	K	L	5	White
Yellow	M	N	6	Black
Gray	P	Q	7	Black
Orange	R	S	8	Black

10. MOUNTING / BARRIERS

	MOUNTING STYLE	BARRIERS	BRACKET COLOR
	Threaded Insert		
1	6-32 x 0.195 inches	no	Black
A	6-32 x 0.195 inches	yes	Black
2	ISO M3 x 5mm	no	Black
B	ISO M3 x 5mm	yes	Black
3	6-32 x 0.195 inches	no	Black
C	6-32 x 0.195 inches	yes	Black
4	ISO M3 x 5mm	no	Black
D	ISO M3 x 5mm	yes	Black
5	6-32 x 0.195 inches	no	White
E	6-32 x 0.195 inches	yes	White
6	ISO M3 x 5mm	no	White
F	ISO M3 x 5mm	yes	White
7	6-32 x 0.195 inches	no	White
G	6-32 x 0.195 inches	yes	White
8	ISO M3 x 5mm	no	White
H	ISO M3 x 5mm	yes	White
9	6-32 x 0.195 inches	no	Gray
J	6-32 x 0.195 inches	yes	Gray
P	ISO M3 x 5mm	no	Gray
K	ISO M3 x 5mm	yes	Gray
Q	6-32 x 0.195 inches	no	Gray
L	6-32 x 0.195 inches	yes	Gray
U	ISO M3 x 5mm	no	Gray
M	ISO M3 x 5mm	yes	Gray

11. MAX. APPLICATION RATING

- A 65VDC
- D 250VAC
- M⁷ 80VDC
- 4⁸ 80VDC / 250VAC

12. AGENCY APPROVAL

- A Without approvals
- C UL Recognized, CSA Accepted
- E UL Recognized, CSA Accepted, TUV Certified
- 5 UL Recognized, CSA Accepted, TUV Certified, CCC Certified

Configure Complete Part Number >

Browse Standard Parts >

Dimensional Specs Curved Rocker

inches [millimeters]

1-POLE (HJ1)

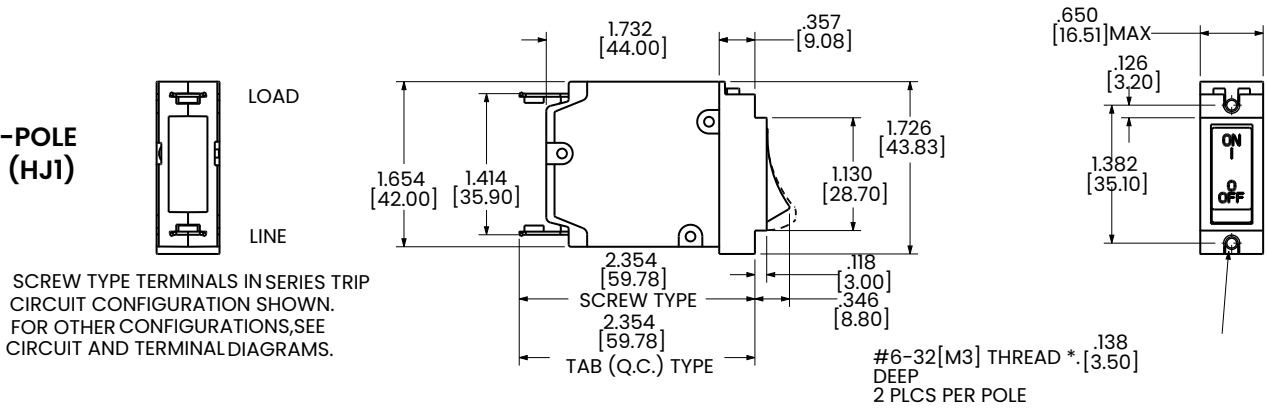

SCREW TYPE TERMINALS IN SERIES TRIP CIRCUIT CONFIGURATION SHOWN. FOR OTHER CONFIGURATIONS, SEE CIRCUIT AND TERMINAL DIAGRAMS.

2-POLE (HJ2)

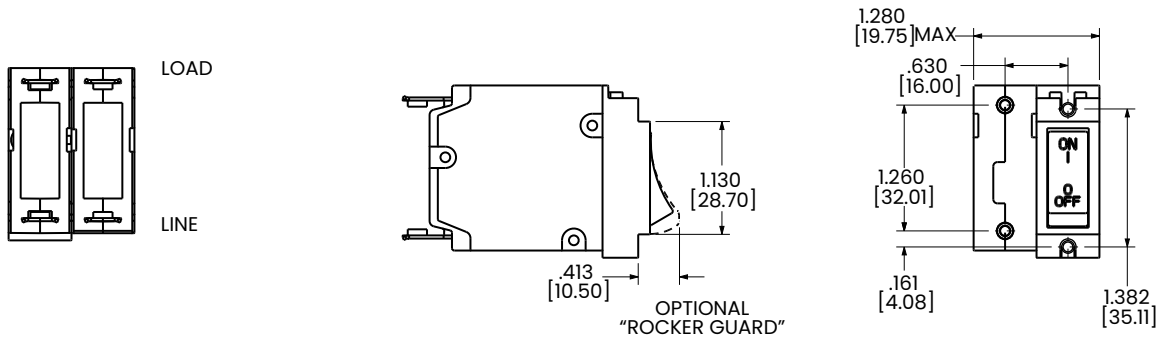

3-POLE (HJ3)

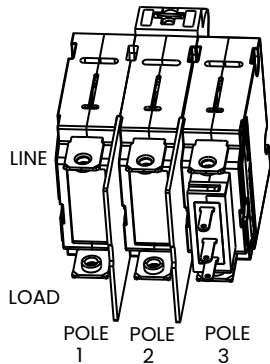
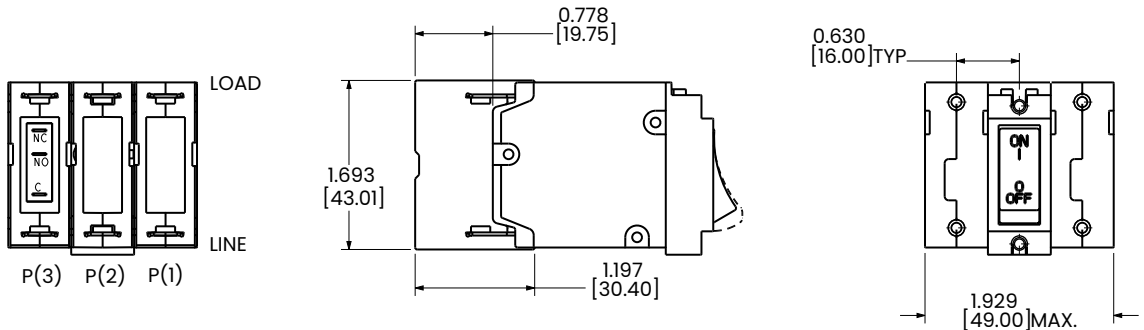

MULTI-POLE IDENTIFICATION SCHEME AS VIEWED FROM TERMINAL END OF BREAKER.

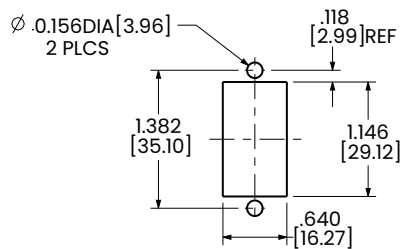

PANEL CUTOFF DETAIL
TOLERANCES ±.005 [±.12]
UNLESS OTHERWISE SPECIFIED

Notes:
1 Tolerance ±.020 [±.51] unless otherwise specified.

Dimensional Specs Flat Rocker

inches [millimeters]

1-POLE (H31)

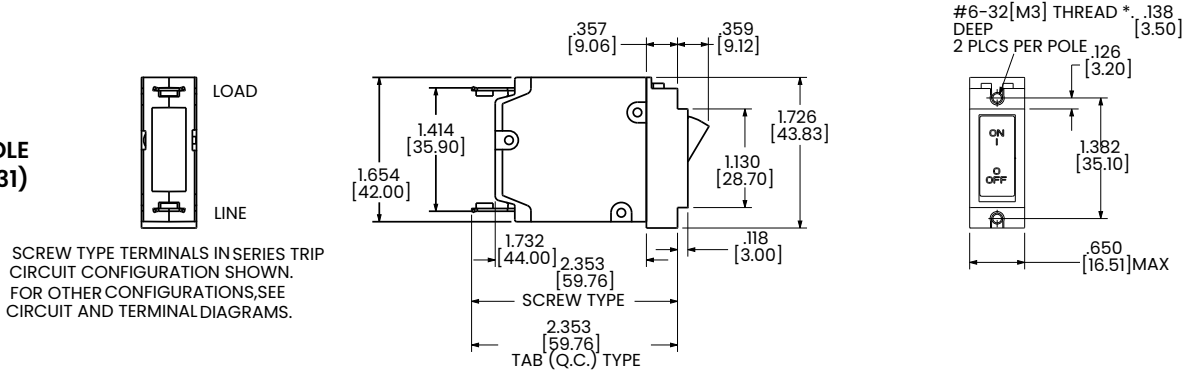

1-POLE (H71)

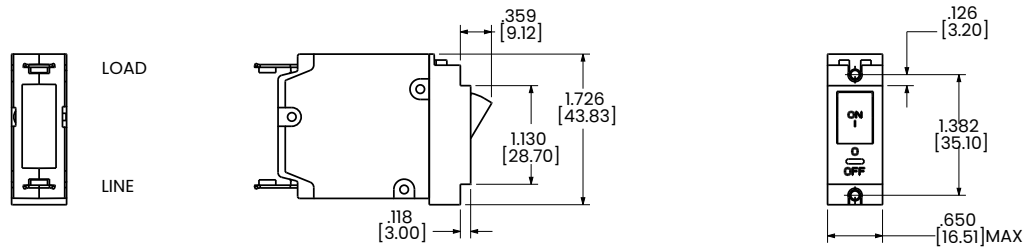

2-POLE (H72)

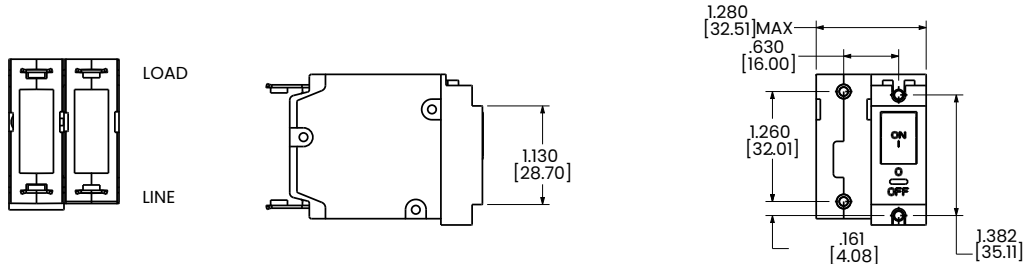

3-POLE (HJ3)

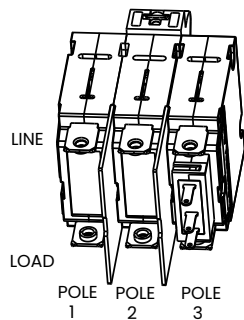
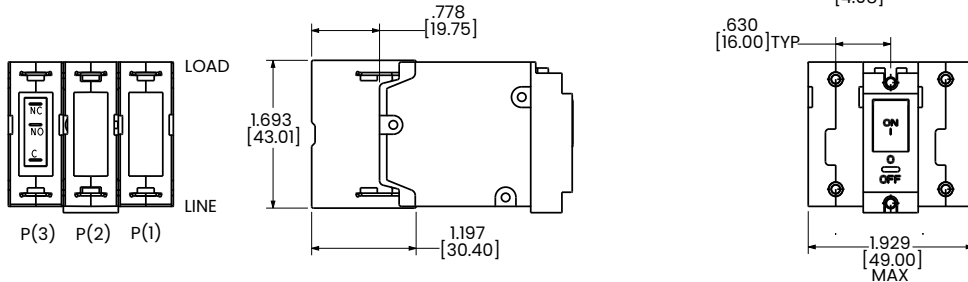

MULTI-POLE IDENTIFICATION SCHEME AS VIEWED FROM TERMINAL END OF BREAKER.

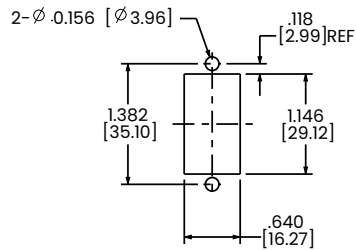

PANEL CUTOUT DETAIL
TOLERANCES ±.005 [±.12]
UNLESS OTHERWISE SPECIFIED

Notes:

1 Tolerance ±.020 [.51] unless otherwise specified.

PC Terminal Diagrams

Rocker (Curved/Flat)

inches [millimeters]

PRINTED CIRCUIT BOARD MOUNTING TERMINAL CODE R

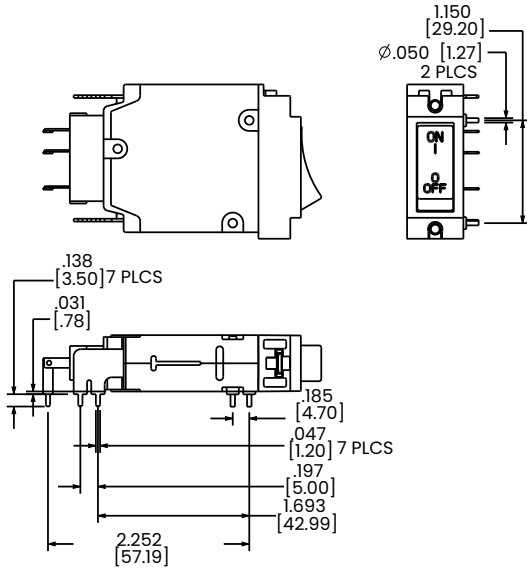

PRINTED CIRCUIT BOARD MOUNTING TERMINAL CODE L

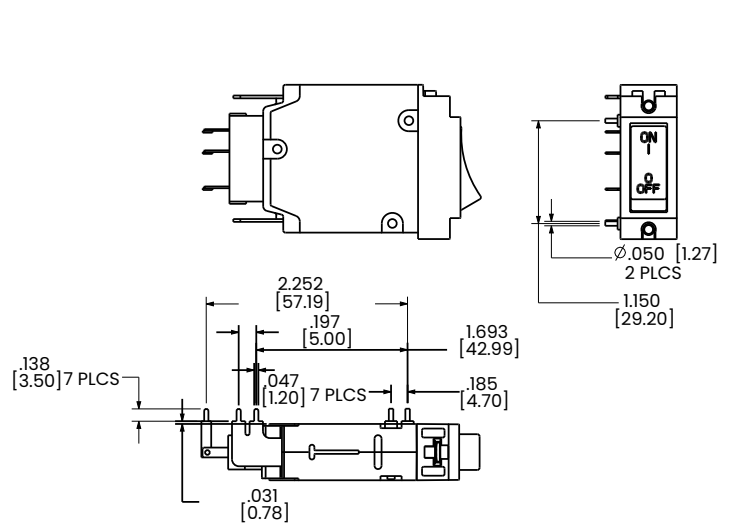

PRINTED CIRCUIT BOARD MOUNTING TERMINAL CODE S & T

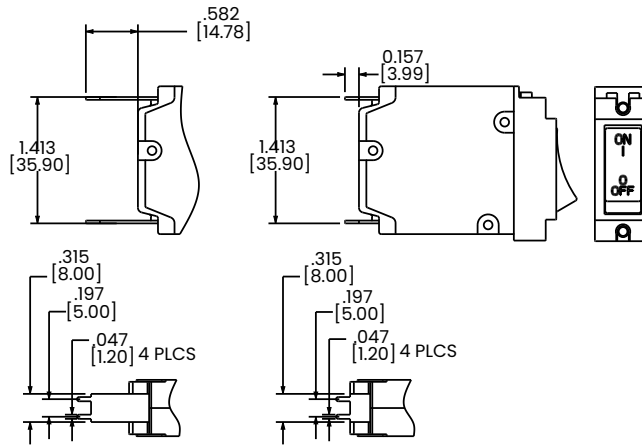

P.C. TERMINAL T

P.C. TERMINAL S

Notes:

1 Tolerance $\pm .020$ [.51] unless otherwise specified.

PC Terminal Diagrams

Rocker (Curved/Flat)

inches [millimeters]

P.C. FOOT PRINT FOR TERMINAL CODE R

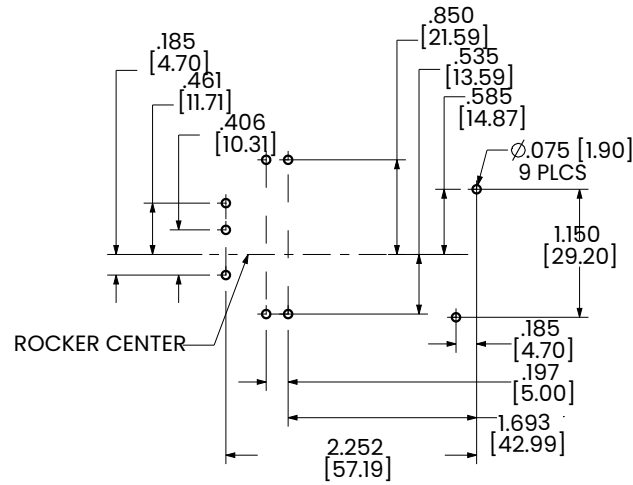

P.C. FOOT PRINT FOR TERMINAL CODE L

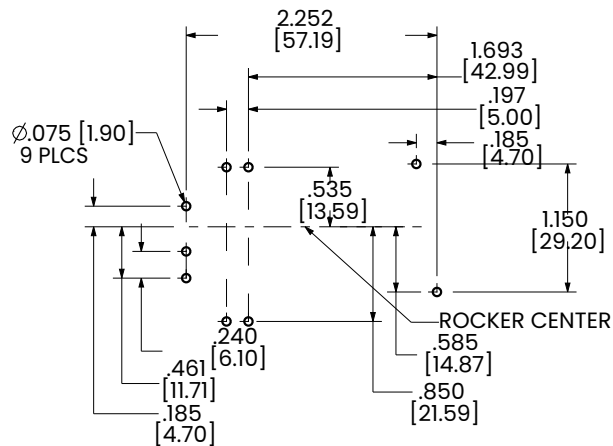

P.C. FOOT PRINT FOR TERMINAL CODE S & T

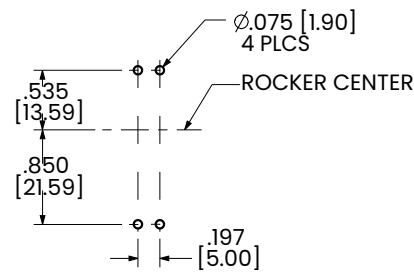

Notes:
1 Tolerance \pm .020 [.51] unless otherwise specified.

Circuit & Terminal Diagram

inches [millimeters]

HANDLE POSITION VS. AUX SWITCH MODE		
STANDARD C/B		
CIRCUIT BREAKER MODE	HANDLE POSITION	AUX. SWITCH MODE
OFF		
ON		
ELECTRICAL TRIP		

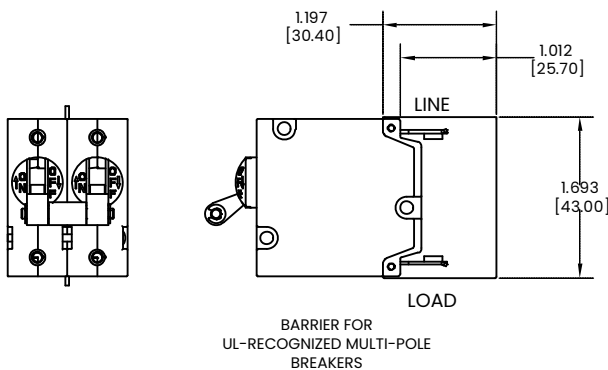
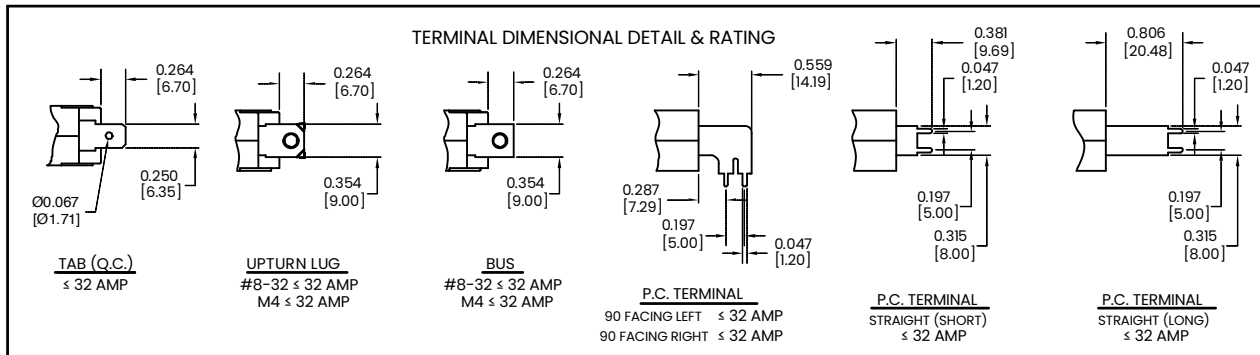
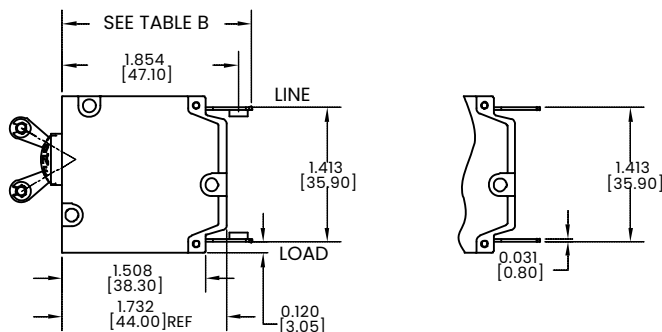

**TABLE A
TIGHTENING TORQUE SPECIFICATIONS**

THREAD SIZE	TORQUE
#6-32 & M3 MOUNTING HARDWARE	7-9 IN-LBS [0.8-1.0 NM]
#8-32 & M4 THREAD TERMINAL SCREW	12-15 IN-LBS [1.4-1.7 NM]

TABLE B

TERMINAL DESCRIPTION		DEPTH BEHIND PANEL
MAIN	TAB (Q.C.)	1.996 [50.70]
	SCREW TYPE	1.996 [50.70]
AUX. SWITCH*	.110 TAB (Q.C.)	2.467 [62.67]
	SOLDER TYPE	2.252 [57.19]



* AVAILABLE ON SERIES TRIP AND SWITCH ONLY CIRCUITS. WHEN CALLED FOR ON MULTI-POLE UNITS, ONLY ONE AUX. SWITCH IS NORMALLY SUPPLIED, AS SHOWN IN MULTI-POLE IDENTIFICATION SCHEME.

1. ALL DIMENSIONS ARE IN INCHES [mm]
2. TOLERANCE ±.020 [.51] UNLESS OTHERWISE SPECIFIED.

Circuit & Terminal Diagram

inches [millimeters]

CIRCUIT BREAKER PROFILE	CIRCUIT SCHEMATIC		CIRCUIT SCHEMATIC			
	ANSI	CIRCUIT CODE	ANSI	CIRCUIT CODE		
2 TERMINALS 	SWITCH ONLY (NO COIL) 	A	0	SERIES TRIP 	B	0
5 TERMINALS 	SWITCH ONLY (NO COIL) WITH AUXILIARY SWITCH 	A	1 2 3	SERIES TRIP WITH AUXILIARY 	B	1 2 3
3 TERMINALS 	SHUNT TRIP 	D E	0			
4 TERMINALS 	RELAY TRIP 	F G	0			

AUXILIARY SWITCH TERMINAL DETAIL

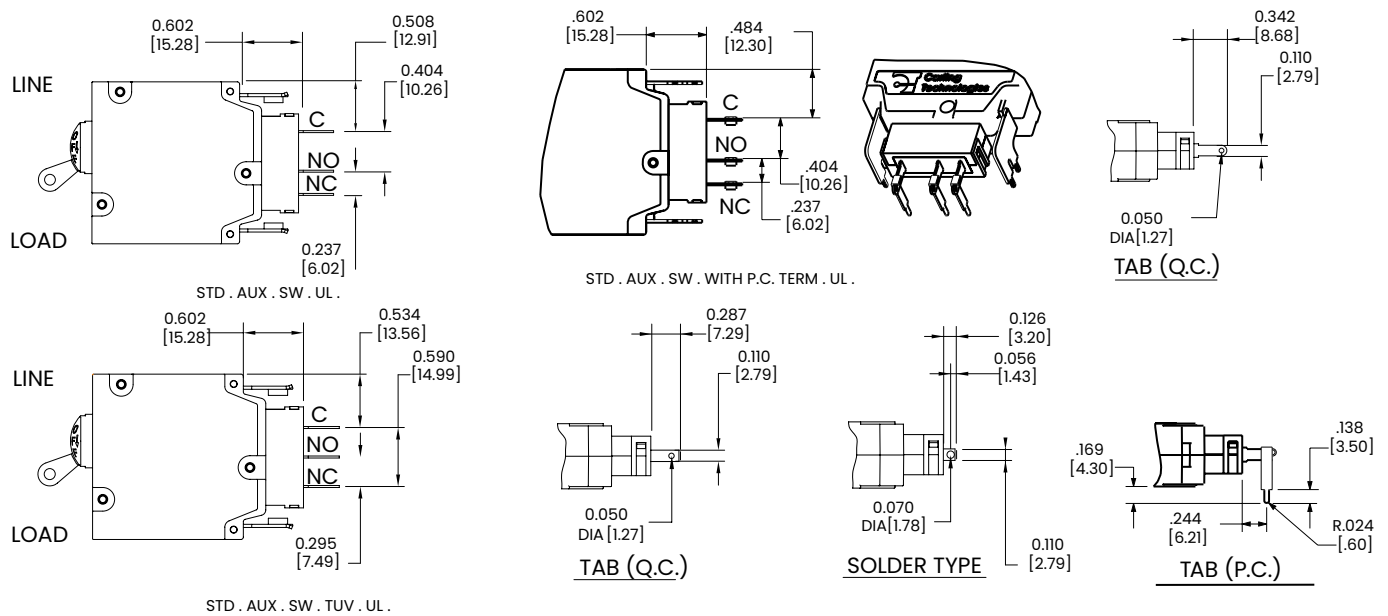

J-Series

Hydraulic Magnetic Circuit Breaker

PRODUCT WEBPAGE

request sample, configure part, watch video



Compact Size, Designed for High Power Density Applications

The J-Series is a compact hydraulic-magnetic circuit breaker featuring a 10,000 amp maximum interrupting capacity, making it ideally suited for high power density applications. This low profile circuit breaker offers a variety of actuator styles and terminal options. The J-Series is available in one to three poles with ratings from 1 to 20 amps, up to 240VAC and a max IC of 10,000 amps.

1-3 Poles **1-20** Amps **240** VAC Max **Up to 10,000AIC** Short Circuit Capacity

Typical Applications

- Datacom/Telecom,
- AC Power Supplies,
- Marine Applications Requiring High Interrupting Capacity
- AC Power Distribution Units
- Power Dense Motors & Controls

Tech Specs

Electrical

Dielectric Strength	Meets UL and cULus requirements and can withstand 1500 VAC, 60Hz for one minute between all electrically isolated terminals.
Insulation Resistance	Minimum of 100 Megohms @ 500VDC
Overload	50 operations @ 600% of rated current for AC rated devices.
Inrush Pulse Tolerance	Standard delays 12 times rated current, high inrush delays 25x for ½ cycle @ 60Hz
Interrupt Capacity	See Table A
Resistance, Impedance	(Across circuit breaker terminals)

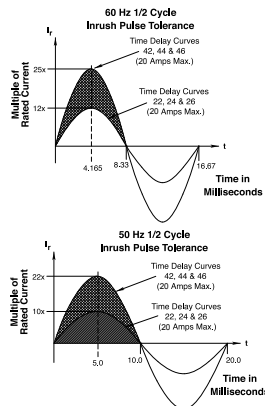
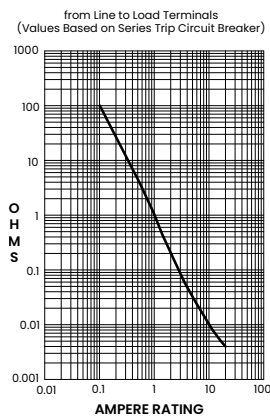

CURRENT (AMPS)	TOLERANCE (%)
0.10 - 5.0	+/- 15
5.1 - 20.0	+/- 25

Mechanical

Endurance	6,000 ON-OFF operations @ 6 per minute; with rated Current and Voltage. 4,000 ON-OFF operations with no load.
Trip Free	All J-Series Circuit Breakers will trip on overload, even when actuator is forcibly held in the ON position.
Trip Indication	The operating actuator moves positively to the OFF position when an overload causes the breaker to trip

Agency Approvals

UL489, cULus CAN/CSA 22.2 No. 5, TUV EN60947-2

Time Delay Specs

To view all hydraulic-magnetic circuit breaker time delay values, please visit www.carlingtech.com/sites/default/files/documents/Carling-HM-CB-Time-Delays.pdf

Tables Table A: Voltage and Current Rating

Electrical Ratings								
Circuit Configuration	Voltage			Current Rating	Short Circuit Capacity (Amps)			Construction Notes
	Max Rating	Frequency	Phase	Full Load Amps	UL / cULus	TUV		
					without backup fuse	with backup fuse	without backup fuse	
Series	120/240 240	50 / 60	1	1.0 - 20.0	10,000	5,000	5,000	2 or 3 Pole 1 or 2 Pole

Physical

Number of Poles	1 - 3 poles
Termination	Designed for use with straight, fork, flanged fork, and ring terminals.
Termination Torque	See dimensional specs page (Table I) for tightening torque specifications (Line and Load terminals)
Terminal Barrier	Foldable barriers to comply with regulatory standards.
Mounting	Threaded Insert: #6-32 UNC-2B or M3 x 0.5-6 H B ISO (2 per Pole).
Insert Termination Torque	7-9 in-lbs
Actuator	Rocker with or without guard
Internal Circuit Configuration	Series Trip, without auxiliary switch
Materials	Housing - Glass Filled Polyester Rocker - Nylon Line/Load Terminals - Copper Alloy; Bright Acid Tin Plated
Weight	~170 Grams (~5.75 Ounces) per pole
Standard Color	Housing - Black. Rocker - Several (see ordering scheme)

Environmental

Designed and tested in accordance with requirements of specification MIL-PRF-55629 & MIL-STD-202 as follows:

Operation Temperature	-40° C to +85° C
Storage Temperature	-40° C to +85° C
Vibration	Withstands 0.060" excursion from 10-55Hz, and 10G's 55-500Hz, at rated current per Method 204C, Test Condition A. Instantaneous and ultrashort curves tested @ 90% of rated current.
Shock	Withstands 100G's, 6ms saw tooth while carrying rated current per Method 213B, Test Condition "I". Instantaneous and ultra short curves tested @ 90% rated current.
Moisture Resistance	Method 106G, i.e., Ten 24-hour cycles at +25°C to +65°C, 80-98% RH.
Salt Spray	Method 101, Condition A (90-95% RH @ 5% NaCl Solution, 96 hours)
Thermal Shock	Method 107G, Condition A (Five cycles @ -55°C to +25°C to +85°C to 25°C)

Ordering Scheme

Rocker

Sample Part Number

J 1 1 - B 0 - 24-620 - 1 1 B - D G

Selection

1 2 3 4 5 6 7 8 9 10 11 12

1. SERIES

J J-Series Circuit Breaker

2. ACTUATOR

FLAT ROCKER:

Two Color Visi-Rocker

- 1 Indicate OFF, vertical legend
- 2 Indicate OFF, horizontal legend

Single color

- 3 Vertical legend
- 4 Horizontal legend

Push-To-Reset, Visi-Rocker

- 5 Indicate OFF, vertical legend
- 6 Indicate OFF, horizontal legend

Push-To-Reset, Single color

- 7 Vertical legend
- 8 Horizontal legend

CURVED ROCKER:

Two Color Visi-Rocker

- C Indicate ON, vertical legend
- D Indicate ON, horizontal legend
- F Indicate OFF, vertical legend
- G Indicate OFF, horizontal legend

Single color

- J Vertical legend
- K Horizontal legend

3. POLES

- 1 One
- 2 Two
- 3 Three¹

4. CIRCUIT

B Series Trip (Current)

5. AUXILIARY SWITCH

0 without Aux Switch

6. FREQUENCY & TIME DELAY

- 20 50 / 60Hz Instantaneous²
- 21 50 / 60Hz Ultra Short
- 22 50 / 60Hz Short
- 24 50 / 60Hz Medium
- 26 50 / 60Hz Long
- 42 50 / 60Hz Short, Hi-Inrush
- 44 50 / 60Hz Medium, Hi-Inrush
- 46 50 / 60Hz Long, Hi-Inrush

7. CURRENT RATING (AMPERES)

CODE	AMPERES						
410	1.00	435	3.50	480	8.00	712	12.50
512	1.25	440	4.00	485	8.50	613	13.00
415	1.50	445	4.50	490	9.00	614	14.00
517	1.75	450	5.00	495	9.50	615	15.00
420	2.00	455	5.50	610	10.00	616	16.00
522	2.25	460	6.00	710	10.50	617	17.00
425	2.50	465	6.50	611	11.00	618	18.00
527	2.75	470	7.00	711	11.50	619	19.00
430	3.00	475	7.50	612	12.00	620	20.00

8. TERMINAL

- 1 Push-On .250 Tab (Q.C.)
- 2 Screw 8-32 with upturned lugs
- 3 Screw 8-32 (Bus Type)
- 4 Screw 10-32 with upturned lugs
- 5 Screw 10-32 (Bus Type)
- 6 Screw 8-32 with upturned lugs and 30° Bend
- 7 Screw 8-32 (Bus Type) and 30° Bend
- 8 Screw 10-32 with upturned lugs and 30° Bend
- 9 Screw 10-32 (Bus Type) and 30° Bend
- B Screw M5 with upturned lugs
- C Screw M4 with upturned lugs
- F Screw M5 with upturned lugs and 30° Bend
- G Screw M5 (Bus Type) and 30° Bend
- H Screw M5 (Bus Type)
- J Screw M5 Back Connect
- K Screw 10-32 Back Connect
- L Screw 10-32 Back Connect, Alt. Spacing³
- M Screw M5 Back Connect, Alt. Spacing³
- N Screw M4 Back Connect
- P Screw M4 Back Connect, Alt. Spacing³
- R Screw 8-32 Back Connect, Alt. Spacing³
- Y Screw 8-32 Back Connect

9. ACTUATOR COLOR & LEGEND ⁴

Actuator or Visi-Color	Marking:		Marking Color:	
	ON-OFF	Dual	Single Color	Visi-Rocker
White	B	1	Black	White
Black	D	2	White	n/a
Red	G	3	White	Red
Green	J	4	White	Green
Blue	L	5	White	Blue
Yellow	N	6	Black	Yellow
Gray	Q	7	Black	Gray
Orange	S	8	Black	Orange

10. MOUNTING ⁵

Standard Rocker Bezel

- A 6-32 x .195 inches 1 6-32 x .195 inches
- B ISO M3 x 5 mm 2 ISO M3 x 5 mm

Rockerguard (Curved Rocker) / Push-to-Reset (Flat Rocker) Bezel

- C 6-32 x .195 inches 3 6-32 x .195 inches
- D ISO M3 x 5 mm 4 ISO M3 x 5 mm

Recessed Off (Flat Rocker)

- E 6-32 x .195 inches 5 6-32 x .195 inches
- F ISO M3 x 5 mm 6 ISO M3 x 5 mm

11. APPLICATION RATING

- C 120 / 240 VAC⁶
- D 240 VAC

12. AGENCY APPROVAL

- A Without Approvals
- G UL 489 Listed, cULus Listed
- 3 UL 489 Listed, cULus Listed, TUV Certified

Notes:

- 1 3 Pole Units available when 1 of 3 poles is neutral.
- 2 20 Delay available only with no agency approvals.
- 3 Refer to dimensional specifications for alternate back connect terminal spacing dimension.
- 4 TUV Approval requires Dual (I-O, ON-OFF) markings.
- 5 For codes A through F, rocker to be on Pole 1 for multi pole breakers with behind the panel standoff bracket on pole 2. For codes 1 through 6, rocker to be on pole 2 for multipole breakers with behind the panel standoff bracket on Pole 1. For 1 & 3 pole breakers use codes A-F.
- 6 Voltage Rating available with 2 and 3 pole breakers only.

[Configure Complete Part Number >](#)

[Browse Standard Parts >](#)

Dimensional Specs Rocker

inches [millimeters]

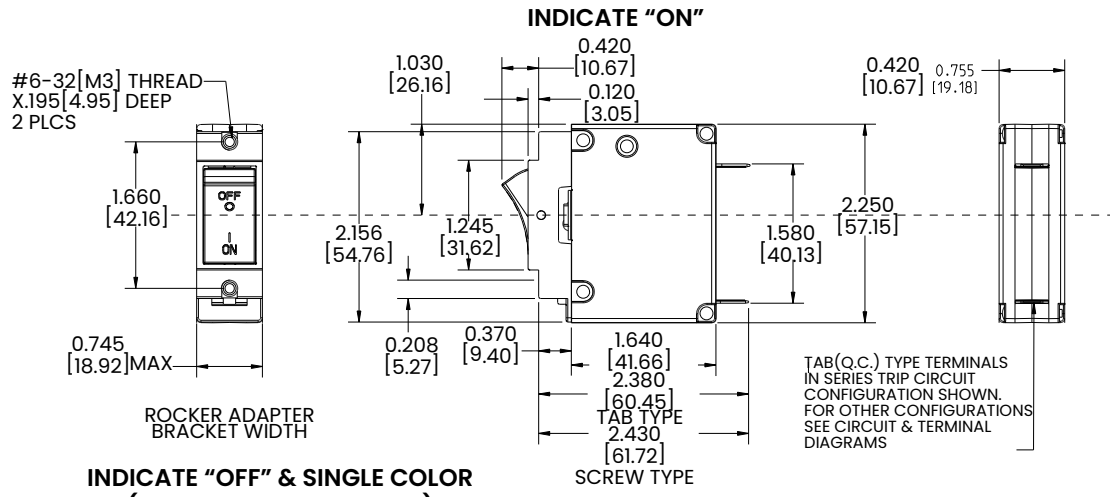

**INDICATE "OFF" & SINGLE COLOR
(INDICATE "OFF" SHOWN)**

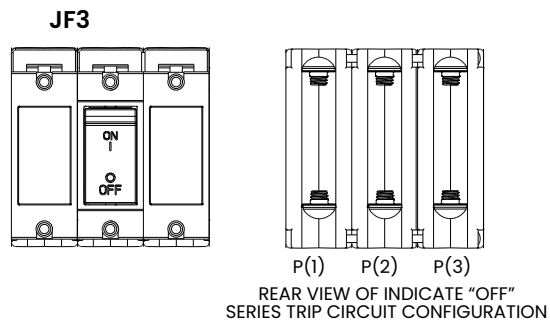
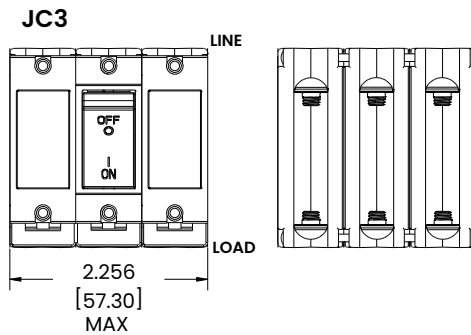
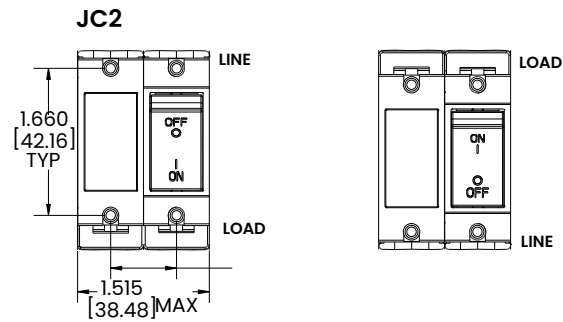
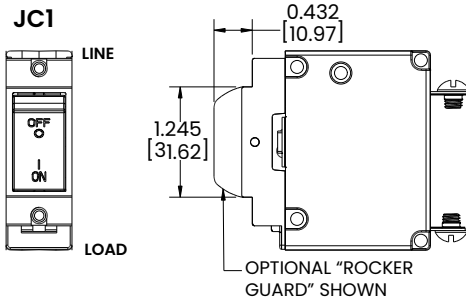
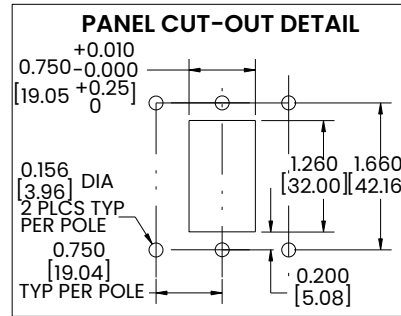
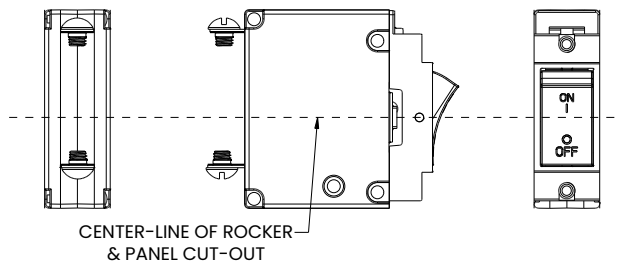

Notes:
1 Tolerance ± 0.020 [51] unless otherwise specified.

Dimensional Specs Rocker

inches [millimeters]

INDICATE "OFF" & SINGLE COLOR (INDICATE "OFF" SHOWN)

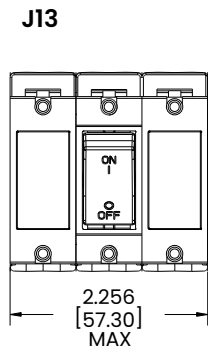
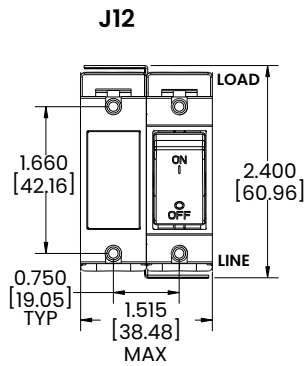
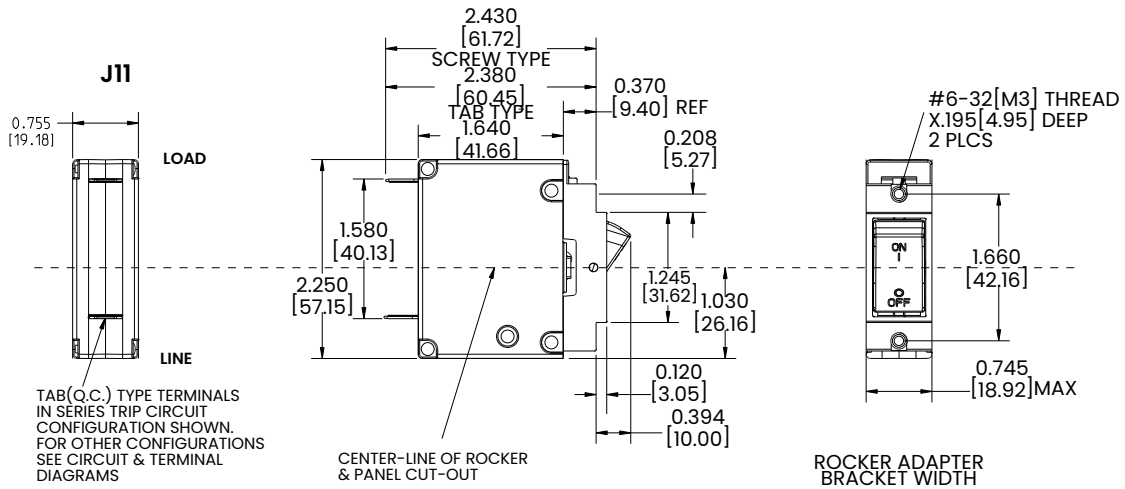

PUSH-TO-RESET ACTUATOR

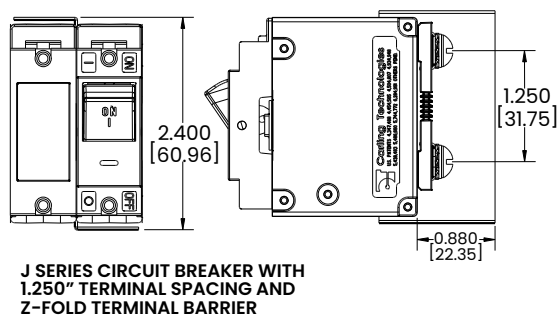
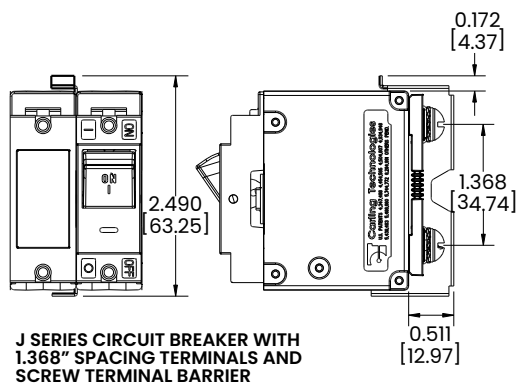
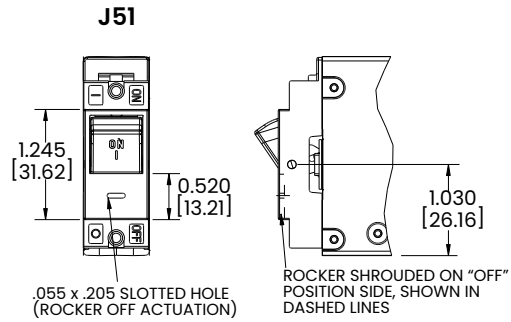

Notes:
1 Tolerance ± 0.020 [.51] unless otherwise specified.

Dimensional Specs

Rocker

inches [millimeters]

TERMINAL SPACING

SCREW TERMINAL & PUSH-IN Q.C. TAB

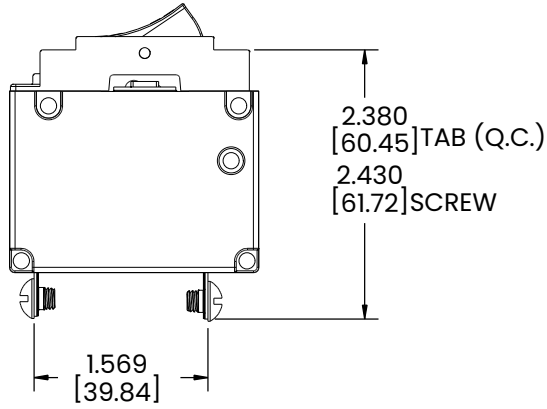

SCREW TERMINAL WITH 30° BEND

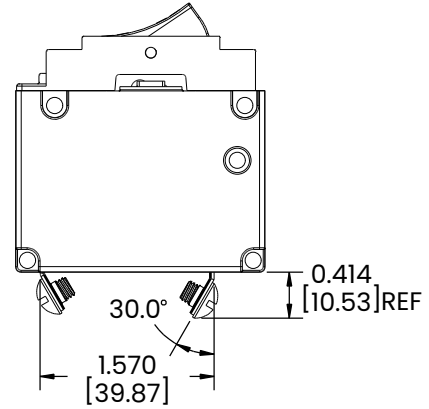

BACK CONNECT SCREW TERMINAL WITH RETAINER

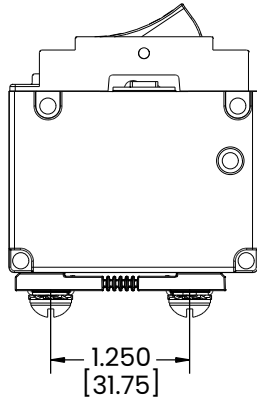

BACK CONNECT SCREW TERMINAL WITH RETAINER-ALTERNATIVE SPACING

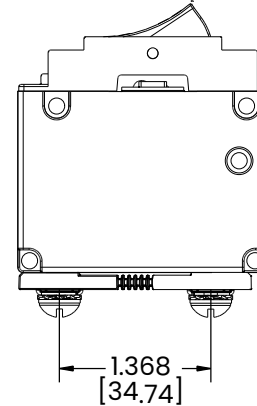

TABLE 1
TIGHTENING TORQUE
SPECIFICATIONS

THREAD SIZE	TORQUE
#6-32 & M3 MOUNTING HARDWARE	7-9 IN-LBS [0.8-1.0 NM]
#8-32 & M4 THREAD TERMINAL SCREW	12-15 IN-LBS [1.4-1.7 NM]
#10-32 & M5 THREAD TERMINAL SCREW	15-20 IN-LBS [1.7-2.3 NM]

Notes:

1 Tolerance ± 0.020 [.51] unless otherwise specified.

Ordering Scheme Handle

Sample Part Number

J A 1 - B 0 - 24 - 620 - 1 2 1 - D 3

Selection 1 2 3 4 5 6 7 8 9 10 11 12

1. SERIES

J J-Series Circuit Breaker

2. ACTUATOR

A Handle, one per pole
B Handle, one per multi-pole unit ¹

3. POLES

1 One **2** Two **3** Three

4. CIRCUIT

B Series Trip (Current)

5. AUXILIARY SWITCH

0 without Aux Switch

6. FREQUENCY & TIME DELAY

21 50 / 60Hz Ultra Short
22 50 / 60Hz Short
24 50 / 60Hz Medium
26 50 / 60Hz Long
42 50 / 60Hz Short, Hi-Inrush
44 50 / 60Hz Medium, Hi-Inrush
46 50 / 60Hz Long, Hi-Inrush

7. CURRENT RATING (AMPERES)

CODE	AMPERES				
410	1.00	435	3.50	480	8.00
512	1.25	440	4.00	485	8.50
415	1.50	445	4.50	490	9.00
517	1.75	450	5.00	495	9.50
420	2.00	455	5.50	610	10.00
522	2.25	460	6.00	710	10.50
425	2.50	465	6.50	611	11.00
527	2.75	470	7.00	711	11.50
430	3.00	475	7.50	612	12.00
				712	12.50
				613	13.00
				614	14.00
				615	15.00
				616	16.00
				617	17.00
				618	18.00
				619	19.00
				620	20.00

Notes:

- Actuator code B (multi-pole only): Handle location as viewed from front of breaker with mounting/barrier code A or B:
 2 pole - right pole 3 pole - center pole
- Refer to dimensional specifications for alternate back connect terminal spacing dimension.
- Single pole only
- ON-OFF markings only available with agency code G. TUV approval requires dual markings
- Codes 1 and 2 are only available for single pole breaker options
 Codes C and D are only available for 2 pole breakers with actuator code B:
 Handle location on left pole as viewed from front of breaker

[Configure Complete Part Number >](#)

[Browse Standard Parts >](#)

8. TERMINAL

1 Push-On .250 Tab (Q.C.)
2 Screw 8-32 with upturned lugs
3 Screw 8-32 (Bus Type)
4 Screw 10-32 with upturned lugs
5 Screw 10-32 (Bus Type)
6 Screw 8-32 with upturned lugs and 30° Bend
7 Screw 8-32 (Bus Type) and 30° Bend
8 Screw 10-32 with upturned lugs and 30° Bend
9 Screw 10-32 (Bus Type) and 30° Bend
B Screw M5 with upturned lugs
C Screw M4 with upturned lugs
F Screw M5 with upturned lugs and 30° Bend
G Screw M5 (Bus Type) and 30° Bend
H Screw M5 (Bus Type)
J Screw M5 Back Connect
K Screw 10-32 Back Connect
L Screw 10-32 Back Connect, Alt. Spacing ²
M Screw M5 Back Connect, Alt. Spacing ²
N Screw M4 Back Connect
P Screw M4 Back Connect, Alt. Spacing ²
R Screw 8-32 Back Connect, Alt. Spacing ²
Y Screw 8-32 Back Connect

9. ACTUATOR COLOR & LEGEND ⁴

Handle Color	ON-OFF	Dual	Legend Color
White	B	1	Black
Black	D	2	White
Red	G	3	White
Yellow	N	6	Black
Black (Short Handle) ³	U	9	White

10. MOUNTING / BARRIERS ⁵

	Barriers
1 6-32 x .195 inches threaded inserts	No
A 6-32 x .196 inches threaded inserts	Yes
2 ISO M3 x 5 mm threaded inserts	No
B ISO M3 x 6 mm threaded inserts	Yes
C 6-32 x .195 inches threaded inserts	Yes
D ISO M3 x 6 mm threaded inserts	Yes

11. APPLICATION RATING

C 120 / 240 VAC (2 and 3 pole only)
D 240 VAC (1 and 2 pole only)

12. AGENCY APPROVAL

A Without Approvals
G UL 489 Listed, cULus Listed
3 UL 489 Listed, cULus Listed, TUV Certified

Dimensional Specs Handle

inches [millimeters]

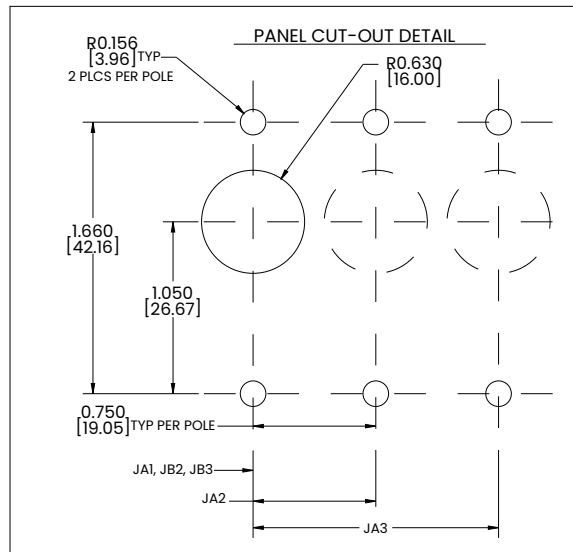
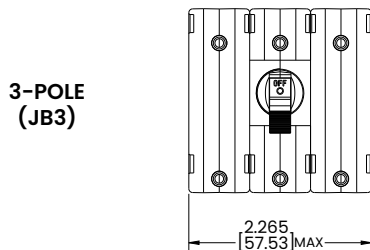
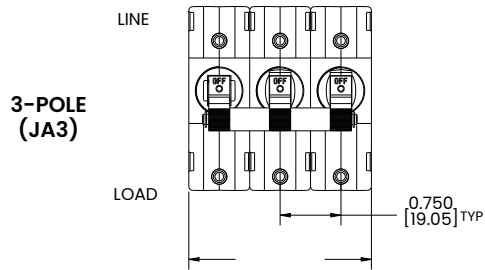
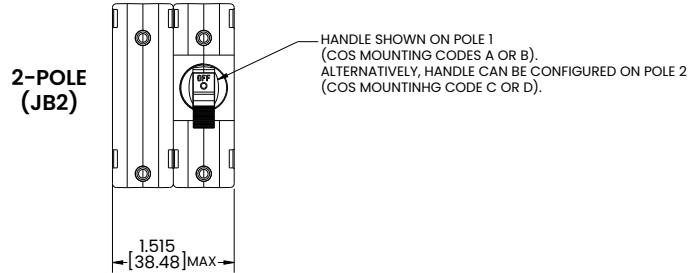
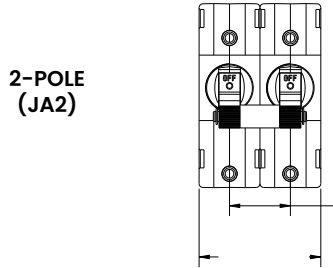
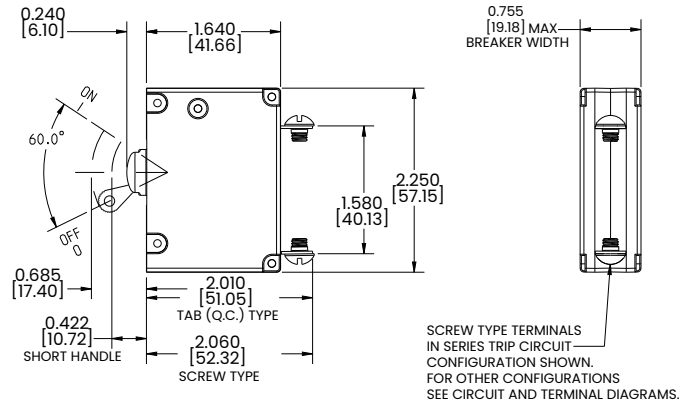
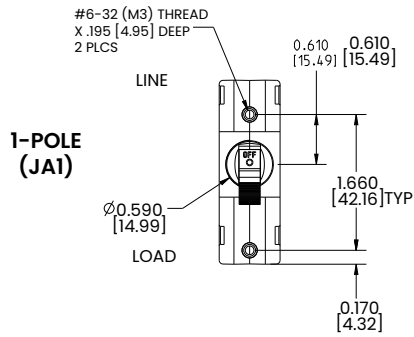

Notes:
1 Tolerance ± 0.020 [51] unless otherwise specified.

Dimensional Specs Handle

inches [millimeters]

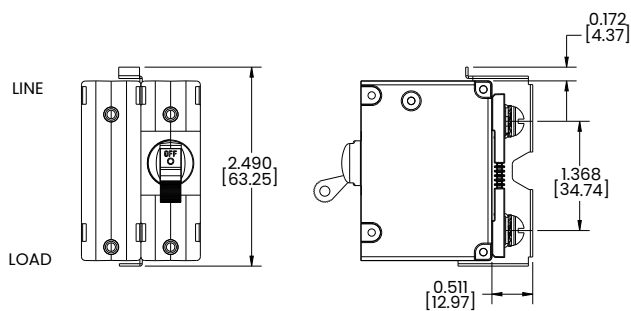
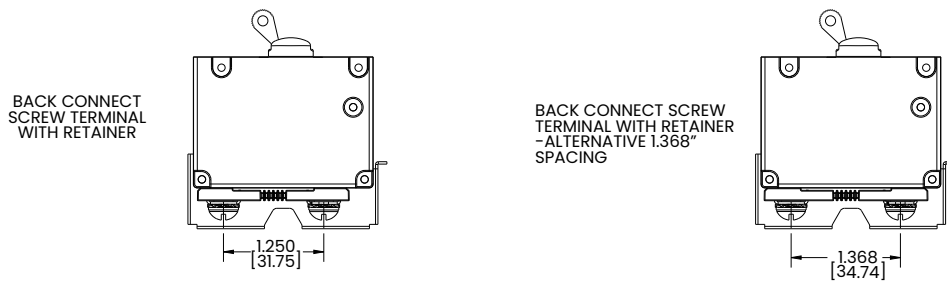

J SERIES CIRCUIT BREAKER WITH 1.368" TERMINAL SPACING AND SCREW TERMINAL BARRIER

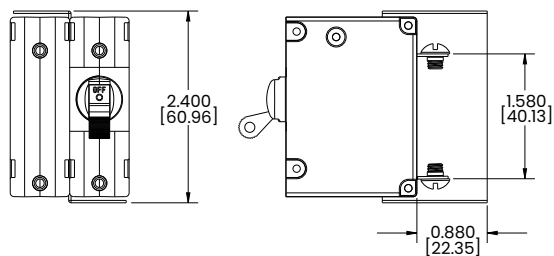

J SERIES CIRCUIT BREAKER WITH 1.250" TERMINAL SPACING AND Z-FOLD TERMINAL BARRIER

Notes:
 1 Tolerance ± 0.020 [.51] unless otherwise specified.

Dimensional Specs

inches [millimeters]

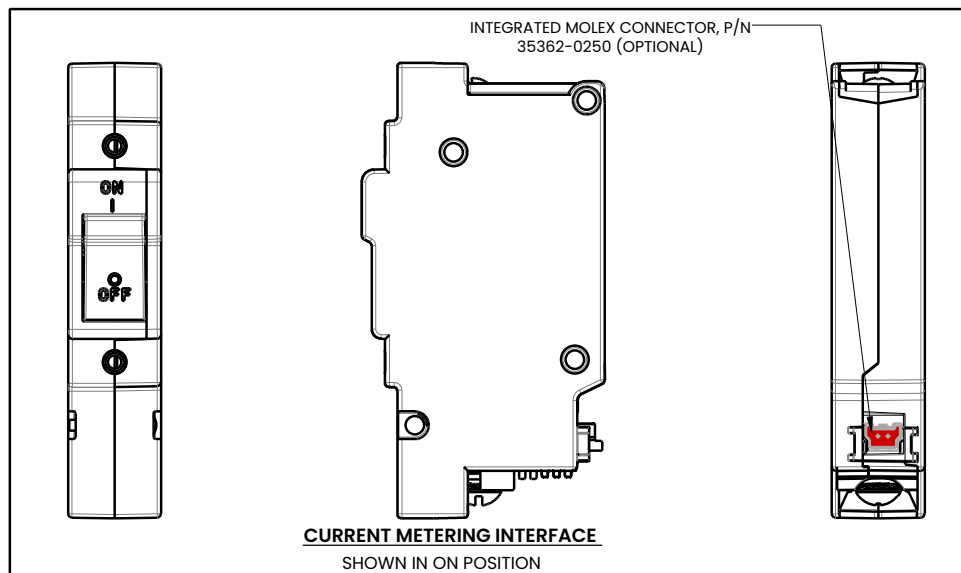
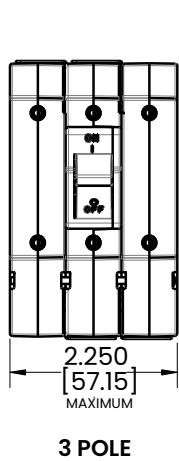
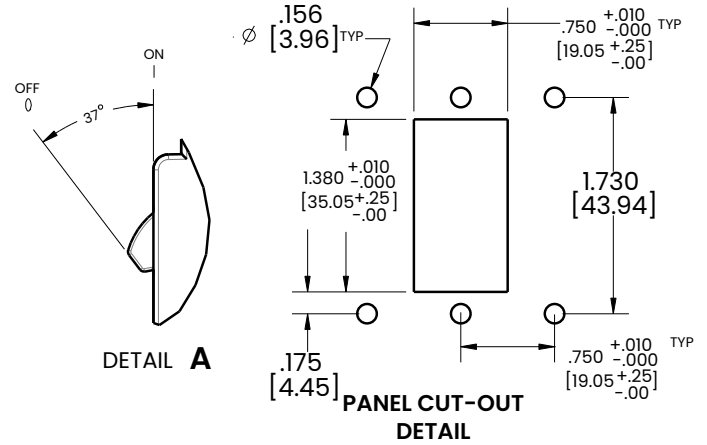
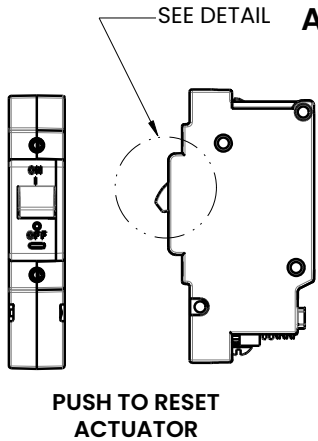
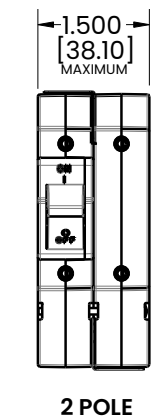
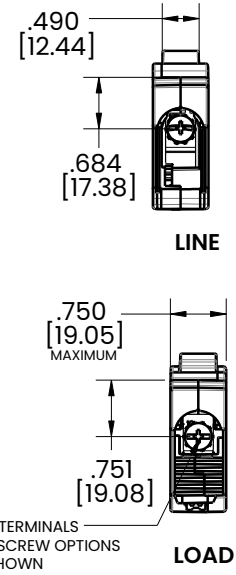
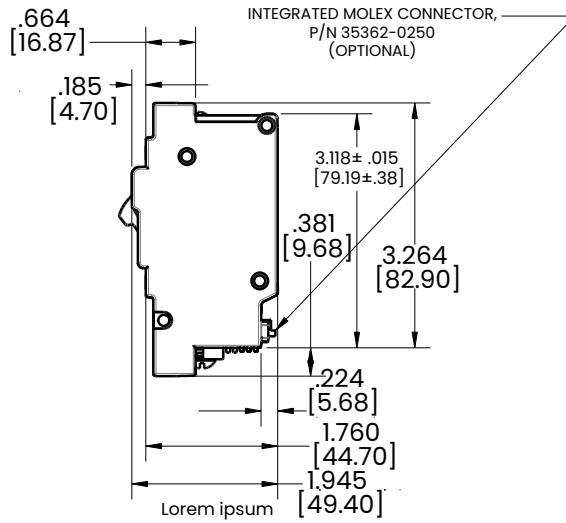
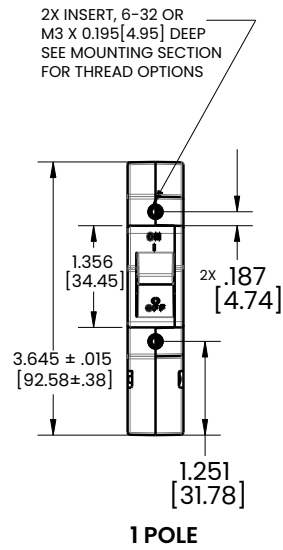

- Notes:
- 1 Screws have combination head
 - 2 Screw thread options: #8-32, #10-32, M4X.7, M5X.8

K-Series

Hydraulic-Magnetic Circuit Breaker

[PRODUCT WEBPAGE](#)

request sample, configure part, watch video



Micro-Sized and Versatile Design

The K-Series is a single-pole hydraulic-magnetic circuit breaker featuring rating options of 65 or 80VDC or 250VAC, making it ideal for a variety of applications including Datacom/Telecom and 5G devices. This low-profile circuit breaker can be configured with PCBA, push-on tab, or screw terminals and is available with instantaneous, short, and medium time-delay options. The K-Series is available with current ratings of 1 to 30 amps.

1	30	250	80
Pole	Amps Max	VAC Max	VDC Max

Typical Applications

- Datacom/Telecom
- 5G Devices
- Power Supplies
- Medical Equipment

Tech Specs

Electrical

Maximum Voltage	AC: 250VAC DC: 80VDC, 65VDC
Current Rating	1-30A
Dielectric Strength	1500 VAC, 50/60Hz for 1 minute between all electrically isolated terminals.
Insulation Resistance	Minimum of 100 Megohms @ 500VDC
Resistance, Impedance	Values from Line to Load Terminal, based on Series Trip Circuit Breaker.

RESISTANCE, IMPEDANCE VALUES from Line to Load Terminals (Values Based on Series Trip Circuit Breaker)

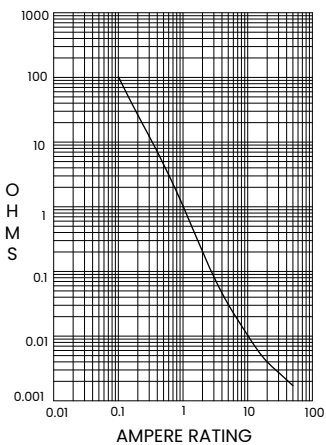

CURRENT (AMPS)	TOLERANCE (%)
1.0-30.0	+/-25%

Interrupt Capacity	See Tables A & B
--------------------	------------------

Mechanical

Endurance	6,000 ON-OFF operations @ 6per minute with rated current and voltage.
Trip Free	All K-Series circuit breakers will trip on overload, even when actuator is forcibly held in the ON position.
Trip Indication	The operating actuator moves positively to the middle position when an overload causes the breaker to trip. The breaker needs to be placed in the OFF position and can then be reset.

Physical

Number of Poles	1 pole
Internal Circuit Configs.	Series without Auxiliary Switch.
Weight	Approximately 27 grams/pole

Environmental

Designed in accordance with requirements of specification MIL PRF-55629 & MIL-STD-202G as follows:

Shock	Withstands 100 Gs, 6ms sawtooth while carrying rated current per Method 213, Test Condition "1". Instantaneous curves tested @ 80% of rated current
Vibration	Withstands 0.060 inch excursion from 10-55 Hz & 10 Gs 55-500 Hz, at rated current per Method 204C, Test Cond. A. Instantaneous curves tested @ 80% of rated current.
Moisture Resistance	Method 106D, i.e., Ten 24-hour cycles @ +25°C to +65°C, 80-98% RH.
Salt Spray	Method 101, Condition A (90-95% RH @ 5% NaCl Solution, 96 hrs)
Thermal Shock	Method 107D, Condition A (five cycles @ -55°C to +25°C to +85°C to +25°C)
Operating Temperature	-40°C to +85°C.

Approvals

UL 489A, UL 1077, CSA 22.2 No. 235, TUV IEC/EN 60934, CCC GB17701

Tech Specs

Tables

Table A: UL Recognized, CSA Approved and CCC Approved configurations and performance capabilities as a Component Supplementary Protector.

Circuit Configuration	Voltage			Current Rating General Purpose Amps	Poles Breaking	Short Circuit Capacity (Amps)			Application Codes	
	Max Rating	Frequency	Phase			UL/CSA	TUV	CCC	UL	CSA
Series	65 ¹	DC	-	1-30	1	1000	1000	500	TC1,2, OL0, U3	TC1,2, OL0, U3
	80 ¹					600	600		TC1,2, OL0, U3	TC1,2, OL0, U3
	250	50/60	1	1-12		800	700	-	TC1,2, OL0, U3	TC1,2, OL0, U3
				12.1-30						

Table B: UL489A Listed configurations and performance capabilities as a Circuit Breakers for use in Communication Equipment.

Circuit Configuration	Voltage		Current Rating General Purpose Amps	Poles Breaking	Short Circuit Capacity (Amps)	
	Max Rating	Frequency			Without Backup Fuse	
					UL489A	TUV
Series	65 ¹	DC	1-30	1	800	1000
	80 ¹				600	600

Notes:
¹ Polarity Sensitive

Ordering Scheme Handle

Sample Part Number **K A 1 - B - 12 - 630 - 1 2 2 - M E**

Selection 1 2 3 4 5 6 7 8 9 10 11

1. SERIES

K K-Series Circuit Breaker

2. ACTUATOR

A Handle, one per pole

3. POLES

1 One

4. CIRCUIT

B Series Trip (Current)

5. FREQUENCY & TIME DELAY

10 DC Instantaneous
12 DC Short
14 DC Medium
20 50/60 Hz Instantaneous
22 50/60 Hz Short
24 50/60 Hz Medium

6. CURRENT RATING (AMPERES)

CODE AMPERES

410 1.00	445 4.50	610 10.00	618 18.00
512 1.25	450 5.00	710 10.50	619 19.00
415 1.50	455 5.50	611 11.00	620 20.00
517 1.75	460 6.00	711 11.50	622 22.00
420 2.00	465 6.50	612 12.00	624 24.00
522 2.25	470 7.00	712 12.50	625 25.00
425 2.50	475 7.50	613 13.00	630 30.00
527 2.75	480 8.00	614 14.00	
430 3.00	485 8.50	615 15.00	
435 3.50	490 9.00	616 16.00	
440 4.00	495 9.50	617 17.00	

7. TERMINAL

1 PCBA soldering terminal (0.197)
2 Push-On 0.250 Tab (Q.C)
3 Screw Terminal 8-32 (Bus Type)

8. ACTUATOR COLOR & LEGEND

Actuator Color	Legend	Legend color
1 White	Dual	Black
2 Black	Dual	White

9. MOUNTING

1 6-32 x .195" Threaded Insert with hook
A 6-32 x .195" Threaded Insert without hook
2 ISO M3 x 5mm Threaded Insert with hook
B ISO M3 x 5mm Threaded Insert without hook

10. MAXIMUM APPLICATION RATING

A¹ 65 VDC
M¹ 80 VDC
D² 250 VAC

11. AGENCY APPROVAL

A Without Approvals
C UL Recognized, CSA Accepted
E UL Recognized, CSA Accepted, TUV certified
J UL 489A Listed & TUV certified
M UL 489A Listed
8 UL Recognized, CSA Accepted, CCC
9 UL Recognized, CSA Accepted, TUV certified, CCC

Notes:

- 1 Polarity Sensitive
- 2 250 VAC only available to 12 amps max for CCC.

 [Configure Complete Part Number >](#)

Dimensional Specs

inches [millimeters]

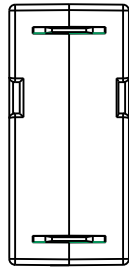
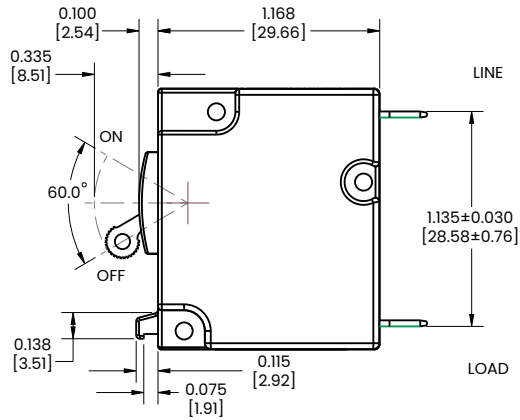
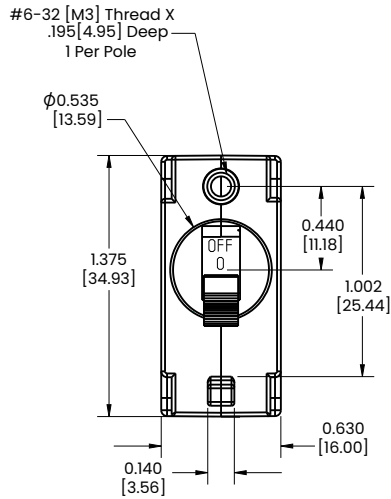

TAB(Q.C.) Type Terminals in Series Trip Circuit Configuration Show. For other Configuration. See Circuit and Terminals Diagrams

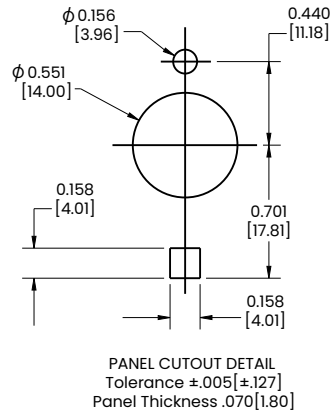

ALTERNATIVE MOUNTING WITHOUT HOOK

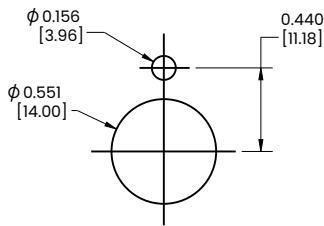
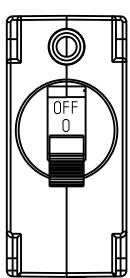

PANEL CUTOUT DETAIL
Tolerance $\pm .005 [\pm 127]$
Panel Thickness .070 [1.80]

TERMINAL DIMENSIONAL DETAIL

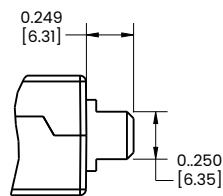

PCBA soldering terminal .197

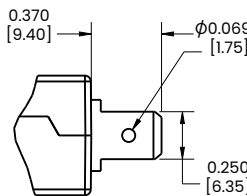

TAB (Q.C.) .250

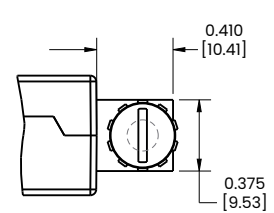

Screw Terminal
#8-32 Bus

Notes:

1. All Dimensions are in inches [Millimeters]
2. Tolerance $\pm .010 [0.25]$ unless otherwise specified
3. Angels $\pm 1^\circ$

L-Series

Hydraulic Magnetic Circuit Breaker

[PRODUCT WEBPAGE](#)

request sample, configure part, watch video



Space Saving Design for Datacom/Telecom Optional Integrated Current Transformer

The L-Series high performance, hydraulic-magnetic circuit breaker is ideal for the confined spaces of datacom/telecom power distribution units and rack systems. The space saving design features an optional current transformer with a 1% sensitivity tolerance for simple monitoring of the power consumed by storage and routing devices. A patented flush rocker actuator and optional push-to-reset guard protect against inadvertent actuation. The L-Series is rated from 0.1-32 amps, up to 240VAC with a max IC of 5,000 amps.

1-3

Poles

1-32

Amps

240

VAC Max

5000

Max Interrupting Capacity

Typical Applications

- Datacom/Telcom: Power Distribution Units, Data Servers, Data Storage

Design Features

1-Pole Configuration with Low Profile Rocker Actuator

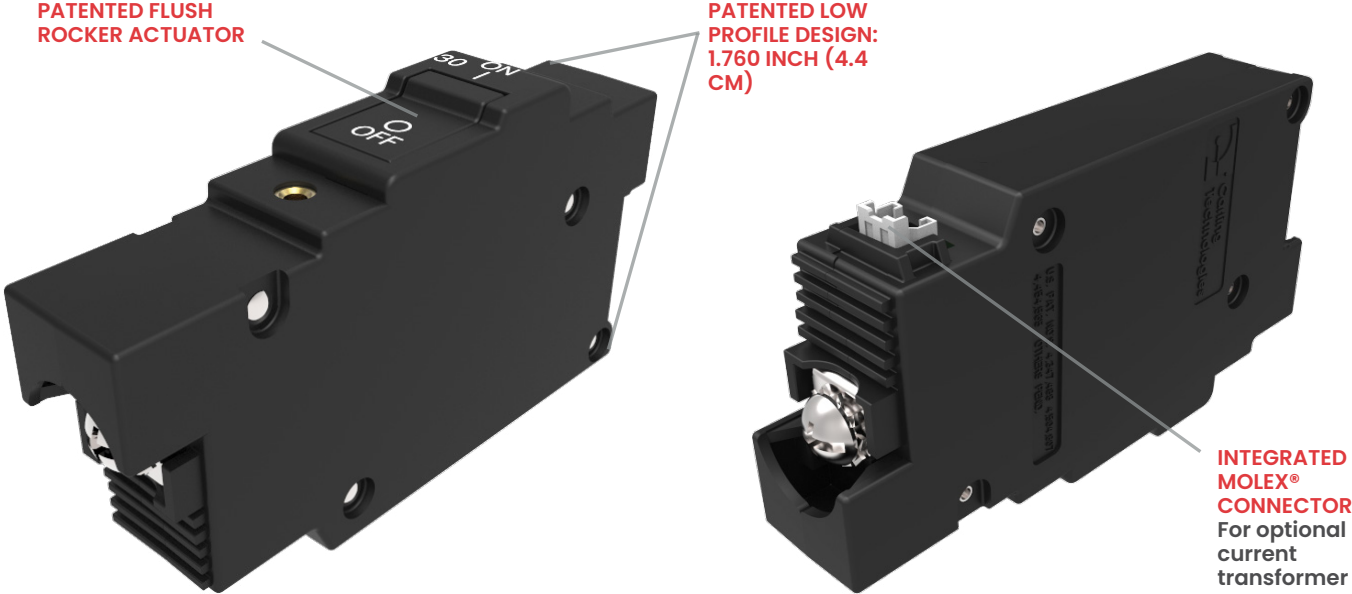

2-Pole Configuration with Push-To-Reset Guard



Tech Specs

Electrical

Maximum Voltage	AC, 415V/240VAC (see table A) UL489, AC, 240VAC (see table A)
Current Ratings	Integrated current transformer. Measurement range: 1-32 Amps Voltage output: 10mV per Amp according to the formula below: $2 \text{ (Amp)} \leq I \leq 32 \text{ (Amp)}$ $V = 0.01 \times I \pm 2\%$ (with current metering codes 1 or 2) $V = 0.01 \times I \pm 1\%$ (with current metering codes 3 or 4).

$$\left| \frac{\frac{V}{I} - \frac{V_{10}}{I_{10}}}{\frac{V_{10}}{I_{10}}} \right| \leq 0.85\%$$

Where V=CT output in volts
V₁₀=CT output in volts with I=I₁₀=10 (A); I=primary current in amperage (50/60 Hz). Phase shift between primary current and CT output is 0.25±0.25°. Maximum crest factor of primary current is 1.73.
R1 shall be integrated in the breaker. R2 and R3 are provided by end user and external to the breaker.
Connection: below Load Terminal.
2-pin connector, Molex® 35362-0250.
Mating Connector housing – Molex® PN35507-0200.

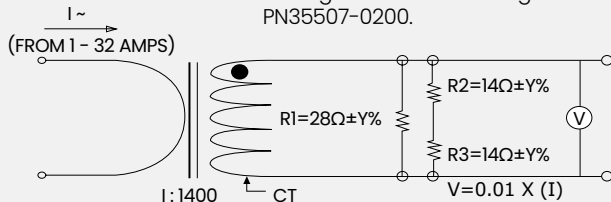

Note: When current metering code is 1 or 2; Y to equal 1.0
When current metering code is 3 or 4; Y to equal 0.1

Dielectric Strength	UL, CSA-1960V 50/60 Hz for one minute between all electrically isolated terminals. Comply with the 8mm spacing and 3750V 50/60 Hz dielectric requirements from hazardous voltage to operator accessible surfaces and between main circuits of adjacent poles per Publications EN 60950 & VDE 0805
Impedance	See next page
Insulation Resistance	Minimum of 100 Megohms@500VDC
Overload	50 operations @ 600% of rated
Interrupt Capacity	See Table A

Agency Approvals

UL489, cULus, TUV (EN60934)

Mechanical

Endurance	Endurance 10,000 "On-Off" Operations @ 6 per minute; with rated Current & Voltage
Trip Free	Trips on overload even when actuator is forcibly held in the "On" position.
Trip Indication	The operating actuator moves positively to the "Off" position when an overload causes the breaker to trip

Physical

Number of Poles	1-3 poles
Termination	Screw Terminals with the following thread sizes: 10-32, 8-32, M5, M4
Termination Barrier	Standard for 2 & 3 poles
Mounting	Threaded Insert: #6-32 UNC-2B, or M3X0.5-6H B ISO (2 per Pole)
Actuator	Rocker, with or without guard
Internal Circuit Config.	Series Trip
Materials	Housing – Glass Filled Polyester Rocker – Nylon 6/6 Line/Load Terminals – Copper Alloy; Bright Acid Tin Plated
Weight	~107 Grams (~3.76 Ounces) per pole
Standard Colors	Housing – Black; Rocker – Black

Environmental

Environmental	MIL-PRF-55629 and MIL-STD-202G
Operating Temperature	-40°C to +85 °C
Vibration	Withstands 0.06" excursion from 10-55 Hz and 10Gs 55-500 Hz at rated current per MIL-PRF-55629 and MIL-STD-202G, Method 204D, Test Condition A. Instantaneous and ultra-short curves tested at 90% of rated current.
Shock	Withstands 100 Gs, 6 ms saw tooth while carrying rated current per MIL-PRF-55629 and MIL-STD-202G, Method 213B, Test Condition "I". Instantaneous and ultra short curves tested at 90% of rated current.
Thermal Shock	MIL-PRF-55629 and MIL-STD-202G, Method 107G, Condition A (5-cycles at -55°C to +25°C to +85°C to +25°C).
Moisture Resistance	MIL-PRF-55629 and MIL-STD-202G, Method 106G, i.e., Ten 24-hour cycles at +25°C to +65°C, 80-98% RH.
Salt Spray	Method 101, Condition A (90-95% RH @ 5% NaCl Solution, 96hrs)

Tech Specs

Tables

Table A: Voltage, Current and IC Ratings

Voltage, Current and AIC Ratings							
Voltage	Current (Amps)	Number of Poles	Phase	Current Metering	Interrupt Capacity (Amps)		
					UL 489 (Amps)	EN60934	
						(Icn) without Backup Fuse	(Inc) with Backup Fuse
240 VAC	0.1 - 32	1	1	Yes	5000	3000	10000
240 VAC	0.1 - 32	2*	1	Yes	5000	3000	10000
240 VAC	0.1 - 20	3	3	Yes	5000	3000	5000
415/240 VAC	0.1 - 20	3	3	Yes	---	3000	5000
120/240 VAC	0.1 - 32	2	1	Yes	5000	N/A	N/A
120/240 VAC	0.1 - 32	3**	1	Yes	5000	N/A	N/A

Notes:

* Breaking both sides of the line

** 3rd pole to be neutral break

Electrical: Impedance (Across circuit breaker main terminals)

RESISTANCE, IMPEDANCE VALUES
from Line to Load Terminals
(Values Based on Series Trip Circuit Breaker)

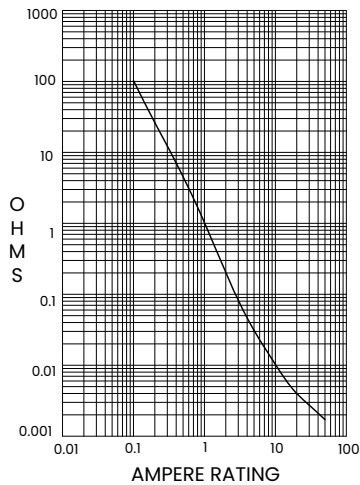

CURRENT (AMPS)	TOLERANCE (%)
0.10 - 5.0	+/- 15
5.1 - 32.0	+/- 25

Time Delay Specs

To view all hydraulic-magnetic circuit breaker time delay values, please visit www.carlingtech.com/sites/default/files/documents/Carling-HM-CB-Time-Delays.pdf

Ordering Scheme

Sample Part Number **L 1 1 - B 0 - 24-620 - 4 2 1 - D G**

Selection 1 2 3 4 5 6 7 8 9 10 11 12

1. SERIES

L

2. ACTUATOR

- 1 Single Color Low Profile Rocker, Vertical Legend
- 2 Single Color Low Profile Rocker, Horizontal Legend
- 3 Single Color Push to Reset Low Profile Rocker, Vertical Legend
- 4 Single Color Push to Reset Low Profile Rocker, Horizontal Legend

3. POLES

- 1 One
- 2 Two
- 3 Three¹

4. CIRCUIT

B Series Trip (Current)

5. CURRENT METERING

- 0 Without Current Transformer
- 1² Integrated Current Transformer, +/- 2%, 1 per unit
- 2 Integrated Current Transformer, +/- 2%, 1 per pole
- 3^{2,6} Integrated Current Transformer, +/- 1%, 1 per unit
- 4⁶ Integrated Current Transformer, +/- 1%, 1 per pole

6. FREQUENCY & TIME DELAY

- 20 50 / 60Hz Instantaneous²
- 21 50 / 60Hz Ultra Short
- 22 50 / 60Hz Short
- 24 50 / 60Hz Medium
- 26 50 / 60Hz Long
- 42 50 / 60Hz Short, Hi-Inrush
- 44 50 / 60Hz Medium, Hi-Inrush
- 46 50 / 60Hz Long, Hi-Inrush

7. CURRENT RATING (AMPERES)

CODE	AMPERES				
410	1.000	440	4.000	490	9.000
512	1.250	445	4.500	495	9.500
415	1.500	450	5.000	610	10.000
517	1.750	455	5.500	710	10.500
420	2.000	460	6.000	611	11.000
522	2.250	465	6.500	711	11.500
425	2.500	470	7.000	612	12.000
527	2.750	475	7.500	712	12.500
430	3.000	480	8.000	613	13.000
435	3.500	485	8.500	614	14.000
				615	15.000
				616	16.000
				617	17.000
				618	18.000
				620	20.000
				622	22.000
				624	24.000
				625	25.000
				630	30.000
				632	32.000

8. TERMINAL

- 2 Screw Terminal, 8-32 (Bus Type)
- 4 Screw Terminal, 10-32 (Bus Type)
- E Screw Terminal, M4 (Bus Type)
- H Screw Terminal, M5 (Bus Type)

9. ACTUATOR COLOR & LEGEND

Actuator Color	I-O	ON-OFF	Dual	Legend Color
White	A	B	1	Black
Black	C	D	2	White
Red	F	G	3	White
Green	H	J	4	White
Blue	K	L	5	White
Yellow	M	N	6	Black
Gray	P	Q	7	Black
Orange	R	S	8	Black

10. MOUNTING INSERTS

- 1 6-32 X .195 Threaded Inserts
- A 6-32 X .195 Threaded Inserts with Terminal Barrier
- 2 ISO M3 X 5 mm Threaded Inserts
- B ISO M3 X 5 mm Threaded Inserts with Terminal Barrier

11. MAX. APPLICATION RATING

- C¹ 120/240 VAC (2 or 3 Pole only)
- D 240 VAC
- P⁴ 415Y/240 VAC (TUV only) 240 VAC 3 phase Delta

12. AGENCY APPROVAL

- A Without approvals
- G UL 489 Listed
- 3 UL 489 Listed, TUV Certified

Notes:

- 1 3 Pole units available only when one of three poles is neutral
- 2 On Multi Pole units one current transformer is supplied on the actuator pole
- 3 Terminal barriers are required on multi poles breaker
- 4 Voltage rating P only available as a 3 pole device 20A max
- 5 Only available with approval code "A"
- 6 +/-1% tolerance only available when used with +/-0.1% tolerance external burden resistor.

[Configure Complete Part Number >](#)

[Browse Standard Parts >](#)

Dimensional Specs

inches [millimeters]

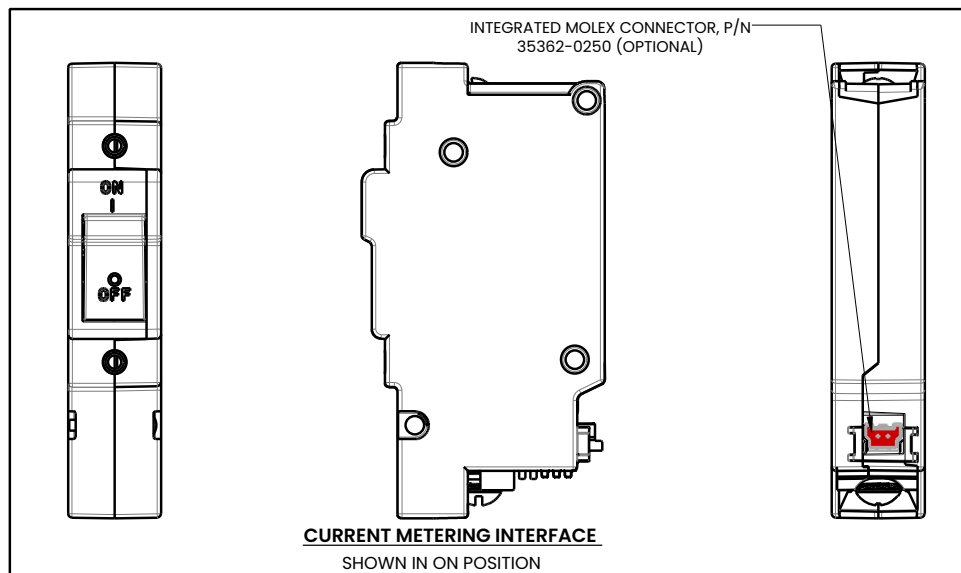
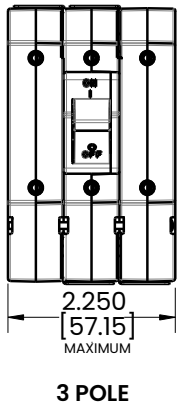
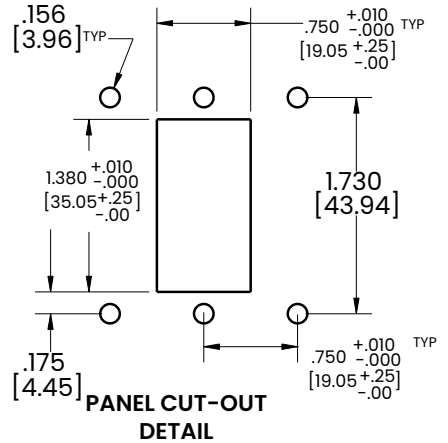
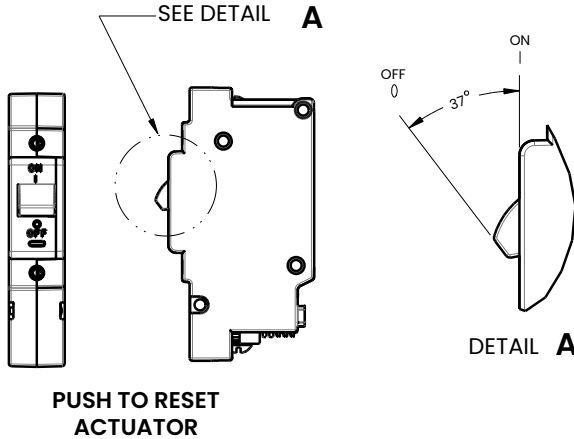
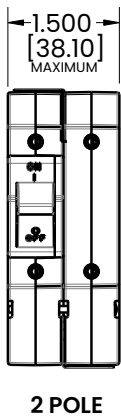
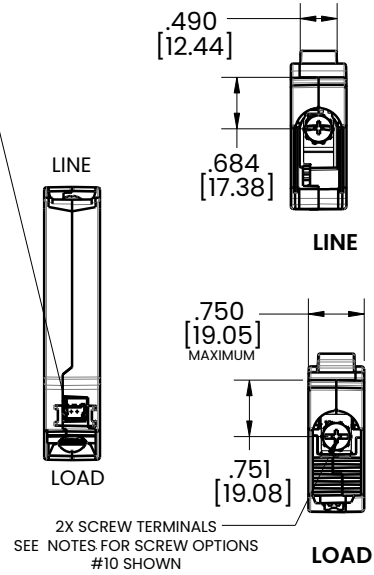
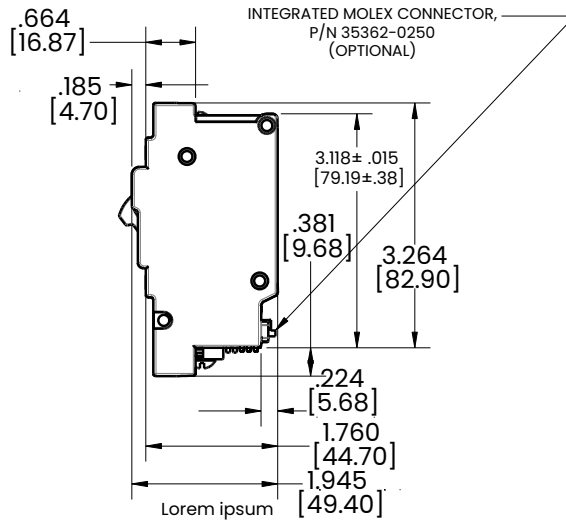
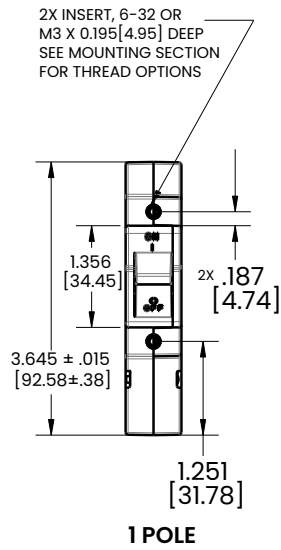

- Notes:
- 1 Screws have combination head
 - 2 Screw thread options: #8-32, #10-32, M4X.7, M5X.8

M-Series

Hydraulic-Magnetic Circuit Breaker

PRODUCT WEBPAGE

request sample, configure part



Miniature Circuit Breaker

The M-Series hydraulic-magnetic circuit breakers offer high performance in a compact, front panel mount design. Multiple agency approvals and options for terminals, panel hardware and actuator styles allow for extensive design flexibility. Wiping contacts assure longevity. These miniature circuit breakers are available as a one to two or parallel pole configuration, rated from 0.02 to 50 amps, up to 250VAC/80VDC with a max IC of 1,000 amps; 600 amps TUV and 500 amps VDE.

1-2	0.2-50	125/250	80
Poles	Amps	VAC Max	VDC Max

Typical Applications

- Telecom
- Marine
- Power Supplies
- Commercial Food
- Transportation
- Generators
- Medical Equipment

Tech Specs

Electrical

Maximum Voltage	125/250 VAC 50/60 Hz, 80 VDC (See Rating Tables.)
Current Ratings	Standard current coils: 0.100, 0.250, 0.500, 0.750, 1.00 thru 15.0 in 1 amp increments, 18.0, 20.0, 25.0, 30.0. Other ratings available - see Ordering Scheme.
Standard Voltage Coils	DC - 6V, 12V; AC - 120V, other ratings available, see ordering scheme.
Auxiliary Switch Rating	SPDT; 7A 250VAC, 7A (Res) 28VDC, 4A (Incl.) 28VDC, 0.25A 80VDC (Res) (silver contacts), 0.1A 125VAC (gold contacts).
Insulation Resistance	Minimum of 100 Megohms at 500 VDC.
Dielectric Strength	UL, CSA 1500V, 50/60 Hz for one minute between all electrically isolated terminals. M-Series Circuit Breakers comply with the 8mm spacing and 3750 V 50/60Hz dielectric requirements from hazardous voltage to operator accessible surfaces, per Publications IEC 380, 435, 950, EN 60950 and VDE 0805.
Resistance, Impedance	Values from Line to Load Terminal - based on Series Trip Circuit Breaker.

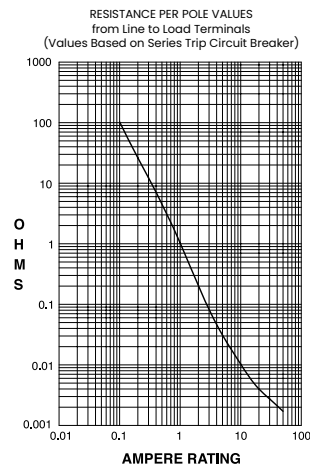

CURRENT (AMPS)	TOLERANCE (%)
0.10 - 20.0	± 25
20.1 - 50.0	± 35

Pulse Tolerance Curves

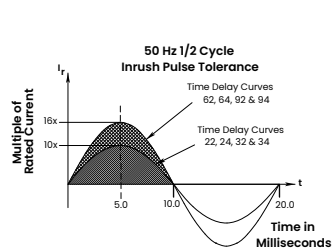
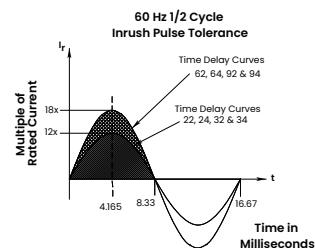

Mechanical

Endurance	10,000 ON-OFF operations @ 6 per minute with rated Current and Voltage.
Trip Free	All M-Series Circuit Breakers will trip on overload, even when actuator is forcibly held in the ON position.
Trip Indication	The actuator moves positively to the OFF position when an overload causes the circuit breaker to trip.

Physical

Number of Poles	1 or 2
Internal Circuit Config.	Series with or without Auxiliary Switch. Switch Only with or without Auxiliary Switch.
Weight	Approximately 30 grams/pole (Approximately 1.07 ounces/pole)
Standard Colors	See Ordering Scheme

Environmental

Designed in accordance with requirements of specification MIL PRF-55629 & MIL-STD-202G as follows:

Shock	Withstands 100 Gs, 6ms, sawtooth while carrying rated current per Method 213, Cond. I. Instantaneous curves tested at 80% of rated current.
Vibration	Withstands 0.060" excursion from 10-55 Hz, and 10 Gs 55-500 Hz, at rated current per Method 204C, Test Condition A. Instantaneous curves tested at 80% of rated current.
Moisture Resistance	Method 106D, i.e., ten 24-hour cycles @ +25°C to +65°C, 80-98% RH.
Salt Spray	Method 101, Condition A (90-95% RH @ 5% NaCl Solution, 96 hrs).
Thermal Shock	Method 107D, Condition A (Five cycles @ -55°C to +25°C to +85°C to +25°C).
Operating Temperature	-40° C to +85° C
Chemical Resistance	Only the outside surfaces of the case and the handles may be cleaned with detergents or alcohol. Organic (hydrocarbon based) solvents are not recommended because they attack plastics. Caution should be taken when solvents are used to clean and remove flux from terminals. Lubricants should not be introduced into the handle/bushing openings

Tech Specs

Tables

Table A: Lists UL Recognized and CSA Accepted configurations & performance capabilities as a Component Supplementary Protector.

Component Supplementary Protectors																							
Circuit Configuration	Voltage			Current Rating		Poles Breaking	Short Circuit Capacity (Amps)				Application Codes												
	Max Rating	Frequency	Phase	Full Load Amps	General Purpose Amps		UL / CSA		Without Backup Fuse	Without Backup Fuse	UL	CSA											
							With Backup Fuse	Without Backup Fuse															
Series	32	DC	---	0.02 - 15	---	1	---	1000	---	---	TC1, 2, OL1, UI	TC1, 2, OL1, UI											
				---	15.1 - 25						TC1, 2, OL0, UI	TC1, 2, OL0, UI											
	50 ²			0.02 - 7.5	---	TC1, 2, OL0, UI					TC1, 2, OL0, UI												
				65	0.02 - 15	---					2	TC1, 2, OL1, UI	TC1, 2, OL1, UI										
	---				15.1 - 25	TC1, 2, OL0, UI					TC1, 2, OL0, UI												
	65 ^{1,2}			0.02 - 15	---	1					TC1, 2, OL1, UI	TC1, 2, OL1, UI											
		---	15.1 - 30	TC1, 2, OL0, UI	TC1, 2, OL0, UI																		
	65	50 / 60	1	0.02 - 15	---	2	5000 ³	---	---	---	TC1, 2, OL1, C1	TC1, 2, OL1, C1											
				---	15.1 - 25						TC1, 2, OL0, C1	TC1, 2, OL0, C1											
	80 ¹			0.02 - 15	---	1					---	600	---	---	---	TC1, 2, OL1, UI	TC1, 2, OL1, UI						
				---	15.1 - 30											TC1, 2, OL0, UI	TC1, 2, OL0, UI						
	125			0.02 - 15	---											1	---	1000	---	---	---	TC1, 2, OL1, UI	TC1, 2, OL1, UI
				---	15.1 - 30																	TC1, 2, OL0, UI	TC1, 2, OL0, UI
	250 ²	1 - 30	---	1	---		360	---	---	---						TC1, OL1, U2		TC3, OL1, U3					
		0.02 - 12	---													1000		TC1, 2, OL1, UI				TC1, 2, OL1, UI	
	250	---	12.1 - 18	2		---	1000 ⁴				---	---	---	TC1, 2, OL0, C1	TC1, 2, OL0, C1								
0.02 - 15		---	1000											TC1, 2, OL1, UI	TC1, 2, OL1, UI								
---	15.1 - 30	2		---			1000							---	---	---	TC1, 2, OL0, UI	TC1, 2, OL0, UI					
1 - 30	---		360														TC1, OL1, U2	TC3, OL1, U3					

Notes:

- 1 Polarity Sensitive
- 2 Available only with Special Catalog Number. Consult Factory.
- 3 Requires Branch Circuit Backup with a UL Listed type K-5 or RK-5 fuse rated 30 Amps maximum
- 4 Requires Branch Circuit Backup with a UL Listed type K-5 or RK-5 fuse rated 60 Amps maximum

Table B: Lists UL Recognized, CSA Accepted and TUV and VDE Certified configurations and performance capabilities as a Component Supplementary Protector.

Component Supplementary Protectors																							
Circuit Configuration	Voltage			Current Rating		Poles Breaking	Short Circuit Capacity (Amps)				Application Codes												
	Max Rating	Frequency	Phase	Full Load Amps	General Purpose Amps		UL / CSA		VDE / TUV		UL	CSA											
							With Backup Fuse	Without Backup Fuse	With Backup Fuse	Without Backup Fuse													
Series	32	DC	---	0.02 - 15	---	1	---	1000	3000	500	---	---	TC1, 2, OL1, UI	TC1, 2, OL1, UI									
				---	15.1 - 25								TC1, 2, OL0, UI	TC1, 2, OL0, UI									
	50 ²			0.02 - 7.5	---	2							5000	---	---	---	---	---	TC1, 2, OL0, UI	TC1, 2, OL0, UI			
				65	0.02 - 15														---	TC1, 2, OL1, UI	TC1, 2, OL1, UI		
	---				15.1 - 25	TC1, 2, OL0, UI													TC1, 2, OL0, UI				
	65 ³			0.02 - 15	---	1													---	600 ⁴	---	---	---
		---	15.1 - 30	TC1, 2, OL0, C1	TC1, 2, OL0, C1																		
	80 ¹	0.02 - 15	---	1	---	1000	---	---	---	---	TC1, 2, OL1, UI	TC1, 2, OL1, UI											
		---	15.1 - 30								TC1, 2, OL0, UI	TC1, 2, OL0, UI											
	125	0.02 - 15	---	1		---					360	---	---	---	---	TC1, 2, OL1, UI	TC1, 2, OL1, UI						
		1 - 15	---													1000	TC1, OL1, U2	TC3, OL1, U3					
	250	0.02 - 12	---	2							---					1000	---	---	---	---	TC1, 2, OL1, UI	TC1, 2, OL1, UI	
		0.02 - 20	---																		360	TC1, 2, OL0, UI	TC1, 2, OL0, UI
	1 - 12	---	1	---	360		---	---	---	---						TC1, OL1, U2						TC3, OL1, U3	

Notes:

- 1 Polarity Sensitive
- 2 Available only with Special Catalog Number. Consult Factory.
- 3 Requires Branch Circuit Backup with a UL Listed type K-5 or RK-5 fuse rated 30 Amps maximum
- 4 TUV only, not VDE
- 5 Requires backup protection with a thermal magnetic circuit breaker rated 32 amps and having a Type C trip characteristic per EN60898/DIN VDE 0641 (C32A) for ratings greater than 15amps, and a thermal magnetic circuit breaker rated 16 amps and having a Type C trip characteristic per EN60898/DIN VDE 0641 (C16A) for ratings 15 amps and less

Tech Specs

Tables

Table C: Lists UL489A Listed and TUV Certified configurations and performance capabilities for use in Communications Equipment.

UL489A Listed (Communications Equipment - Polarity Sensitive)						
Circuit Configuration	Voltage		Current Rating General Purpose Amps	Poles Breaking	Interrupting Capacity (Amps)	
	Max Rating	Frequency			Without Backup Fuse	
					UL489A	TUV
Series	80	DC	0.02 - 30	1	600	---
	65 ¹				1000	---
	80		0.10 - 30		600	600

Notes:
1. Available only with Special Catalog Number

Table D: Lists UL489A Listed configurations and performance capabilities for use in Communications Equipment.

Parallel Pole Construction UL489A Listed (Communications Equipment - Polarity Sensitive)						
Circuit Configuration	Voltage		Current Rating General Purpose Amps	Poles Breaking	Interrupting Capacity (Amps)	
	Max Rating	Frequency			Without Backup Fuse	
					UL489A	
Series	80	DC	31 - 50	2	600	
	65 ¹				1000	

Notes:
1. Available only with Special Catalog Number

Agency Approvals

UL 1077

Component Recognition Program as Protectors, Supplementary (Guide CCN/QVNU2, File E75596)

UL 489A

Communications Equipment (Guide CCN/DITT, File E189195)

CSA Accepted

Component Supplementary Protector (Class 3215 30, File 047848 0 000)
CSA Standard C22.2 No. 235

VDE Certified

EN60934, VDE 0642 under File 10537

TUV Certified

EN60934, under License No. R9671109

Time Delay Specs

To view all hydraulic-magnetic circuit breaker time delay values, please visit www.carlingtech.com/sites/default/files/documents/Carling-HM-CB-Time-Delays.pdf

Ordering Scheme Rocker – Parallel Pole

Sample Part Number

M E 2 - P - D2 - 650 - 5 - A 1 2 - B - T

Selection 1 2 3 4 5 6 7 8 9 10 11 12

1. SERIES

M

2. ACTUATOR ¹

Single Color
A Angled
B Flat

Two Color Visi
D Indicate ON
E Indicate OFF

Single Color Translucent
F Angled
G Flat

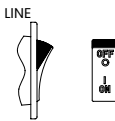
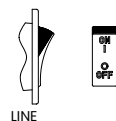
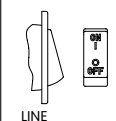
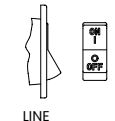
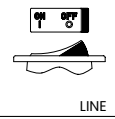
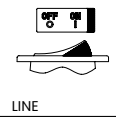
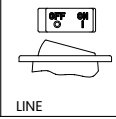
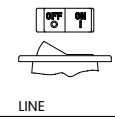
STYLE	INDICATE - "ON" (CODE-D)	INDICATE - "OFF" (CODE-E)	FLAT (CODES-B&G)	ANGLED (CODES-A&F)
VERTICAL	 LINE	 LINE	 LINE	 LINE
HORIZONTAL	 LINE	 LINE	 LINE	 LINE

3. POLES

2 Two

4. CIRCUIT/ AUXILIARY SWITCH ²

P Series Trip Current (Parallel Pole)
with Auxiliary Switch, Silver Contacts

Q Series Trip Current (Parallel Pole) .110 x 0.20 Q.C

with Auxiliary Switch, Gold Contacts

R Series Trip Current (Parallel Pole) .110 x 0.20 Q.C

5. FREQUENCY & TIME DELAY

D2 DC Short
D4 DC Medium

6. CURRENT RATING (AMPERES)

CODE	AMPERES
631	31.000
635	35.000
640	40.000
645	45.000
650	50.000

7. TERMINAL

A Push in Stud
5 10-32 Screw (Bus Type)

8. ILLUMINATION

Non-Illuminated
A Non-Illuminated

9. ACTUATOR COLOR & LEGEND

Actuator Visi ¹	Legend
1 White	Black
2 Black	White
3 Red	White
4 Green	White
5 Blue	White
6 Yellow	Black
7 Gray	Black
8 Orange	Black

10. LEGEND

2 ON - OFF Vertical
3 ON - OFF Horizontal
6 Dual Vertical
7 Dual Horizontal

11. BEZEL COLOR

A White without Rockerguard
B Black without Rockerguard
G Gray without Rockerguard

1 White with Rockerguard
2 Black with Rockerguard
7 Gray with Rockerguard

12. AGENCY APPROVAL

T UL 489A Listed

Notes:

- ¹ Remainder of Rocker same color as Visi
² Aux Switch only available with screw terminals

[Configure Complete Part Number >](#)

[Browse Standard Parts >](#)

Ordering Scheme

Handle/Pushbutton – Parallel Pole

Sample Part Number **M M 2 - P - D2 - 650 - 5 - 1 B B - B - T**

Selection 1 2 3 4 5 6 7 8 9 10 11 12

1. SERIES

M

2. ACTUATOR ¹

M Paddle
T Push-Pull

3. POLES

2 Two

4. CIRCUIT/ AUXILIARY SWITCH ²

P Series Trip Current (Parallel Pole)
with Auxiliary Switch, Silver Contacts
Q Series Trip Current (Parallel Pole) .110 x 0.20 Q.C
with Auxiliary Switch, Gold Contacts
R Series Trip Current (Parallel Pole) .110 x 0.20 Q.C

5. FREQUENCY & TIME DELAY

D2 DC Short
D4 DC Medium

6. CURRENT RATING (AMPERES)

CODE	AMPERES
631	31.000
635	35.000
640	40.000
645	45.000
650	50.000

7. TERMINAL

A Push in Stud
5 10-32 Screw (Bus Type)

8. ACTUATOR COLOR & LEGEND

Handle	Push Button
1 White	A White
2 Black	B Black
3 Red	C Red
4 Green	D Green
5 Blue	E Blue
6 Yellow	F Yellow
7 Gray	G Gray
8 Orange	H Orange

9. FRONT PANEL HARDWARE

Handle

A No outer Panel Hardware
B Knurled Nut, Bright Nickel
C Knurled Nut, Bright Nickel with Locking Ring
D Knurled Nut, Black
E Knurled Nut, Black with Locking Ring
F Panel Dress, Bright Nickel
G Panel Dress, Bright Nickel with Locking Ring
H Panel Dress, Black
J Panel Dress, Black with Locking Ring

Push Button

1 No outer Panel Hardware
2 Knurled Nut, Bright Nickel

10. LEGEND PLATE / BUTTON MARKING

Handle Actuator Legend Plate

B ON - OFF Vertical
C ON - OFF Horizontal

Push-Pull Actuator Legend Plate

2 Rated Amps Horizontal
3 Rated Amps Line Side Down
4 Rated Amps Line Side Up

11. BUSHING COLOR

B Black

12. AGENCY APPROVAL

T UL 489A Listed

Notes:

1 Remainder of Rocker same color as Visi
2 Aux Switch only available with screw terminals

[Configure Complete Part Number >](#)

[Browse Standard Parts >](#)

Dimensional Specs Parallel Pole

inches [millimeters]

PARALLEL POLE TERMINAL OPTIONS

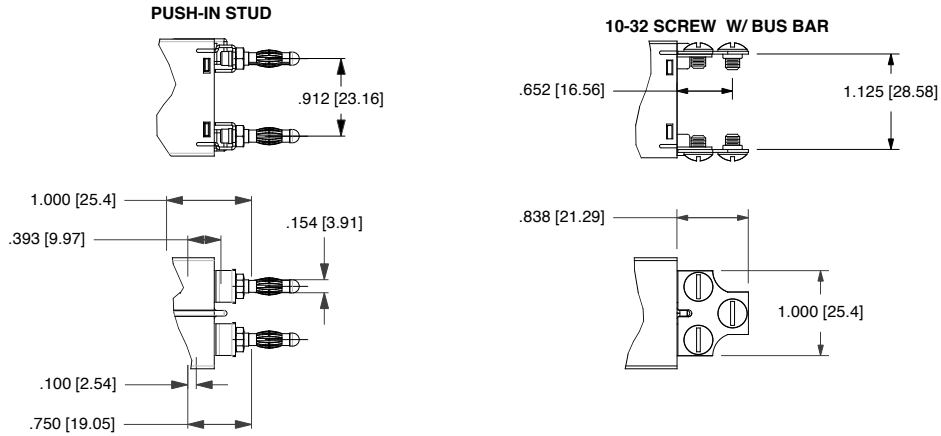

ROCKER ACTUATOR DETAIL

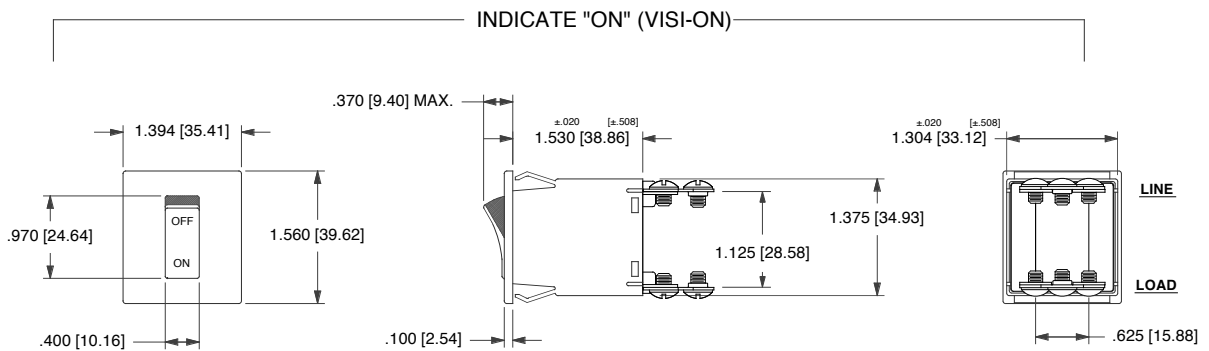

INDICATE "OFF" (VISI-OFF) & SINGLE COLOR

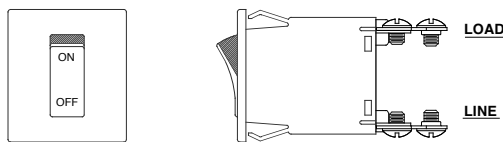

ROCKERGUARD CONFIGURATION

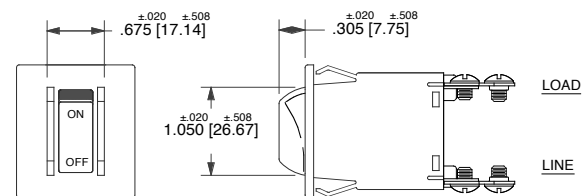

PANEL CUT - OUT DETAIL (ROCKER)

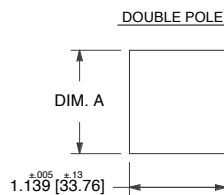

PANEL THICKNESS	DIM. A
.062 [1.57]	1.385 [35.18]
.093 [2.36]	1.420 [36.07]
.125 [3.18]	1.460 [37.08]

- Notes:
- 1 Tolerance ± 0.10 [25] unless otherwise specified.
 - 2 Dimensions apply to both rocker styles.
 - 3 I-o, on-off or dual legends available for vertical or horizontal mounting.
 - 4 Notice that circuit breaker line and load terminal orientation on indicate "off" is opposite that of indicate "on".

Dimensional Specs Parallel Pole

inches [millimeters]

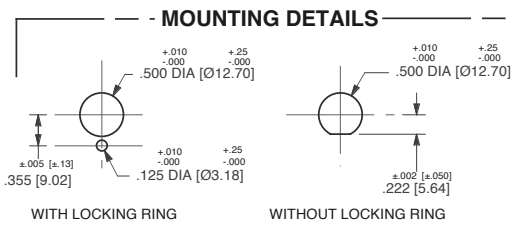
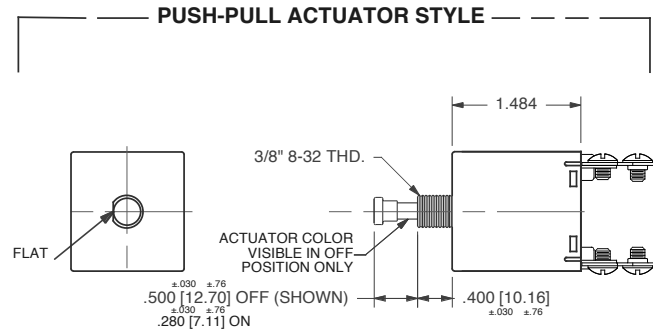
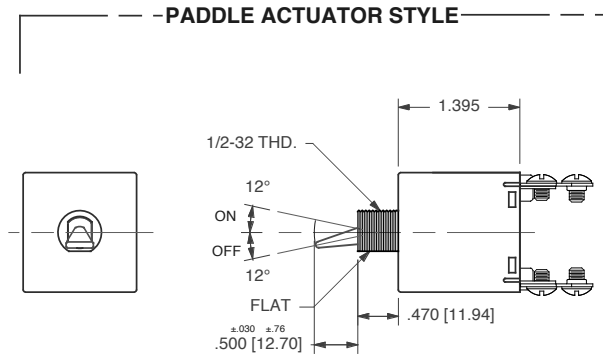

MOUNTING DETAILS

PANEL HARDWARE

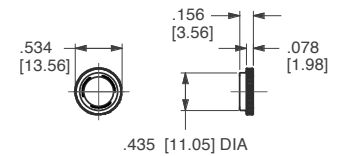
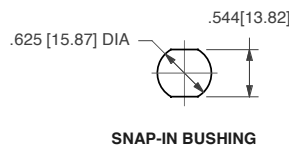
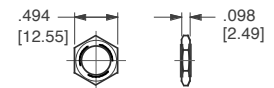
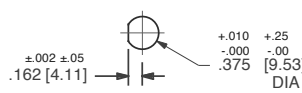

LEGEND PLATES

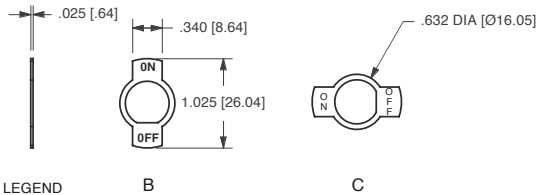

LEGEND CODE:

BUTTON MARKING ORIENTATION

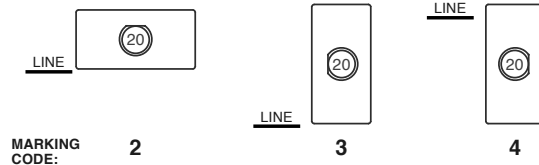

PANEL HARDWARE

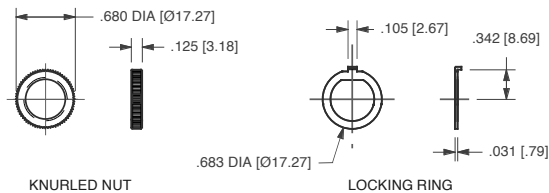
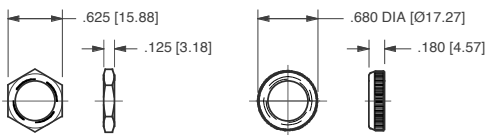

.110QC AUXILIARY SWITCH TERMINALS

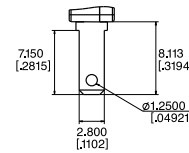

Notes:

- 1 Tolerance ±.010 [25] unless otherwise specified.
- 2 Dimensions apply to both rocker styles.
- 3 I-o, on-off or dual legends available for vertical or horizontal mounting.
- 4 Notice that circuit breaker line and load terminal orientation on indicate "off" is opposite that of indicate "on".

Ordering Scheme

Rocker - UL 1077 Recognized

Sample Part Number **M G 2 - B - 34 - 620 - 1 - H C 6 - 7 - C**

Selection 1 2 3 4 5 6 7 8 9 10 11 12

1. SERIES

M

2. ACTUATOR 1

Non-Illuminated single color
A Angled
B Flat

Two Color Visi-Rocker
D Indicate ON
E Indicate OFF

Illuminated single color
F Angled
G Flat

STYLE	INDICATE - "ON" (CODE=D)		INDICATE - "OFF" (CODE=E)	
	FLAT (CODES=B&G)	ANGLED (CODES=A&F)	FLAT (CODES=B&G)	ANGLED (CODES=A&F)
VERTICAL				
HORIZONTAL				

3. POLES

1 One 2 Two

4. CIRCUIT 2

without Auxiliary Switch
A Switch Only (no coil), Maintained Contacts
B Series Trip (Current)

with Auxiliary Switch, Silver Contacts
M Series Trip (Current) Aux Switch
P 3 Switch Only, Maintained Contacts
R 3,15 Switch Only, Maintained Contacts
S 3 Series Trip (Current)
U 3,15 Series Trip, Maintained Contacts

with Auxiliary Switch, Gold Contacts
3 3,15 Switch Only, Maintained Contacts
5 3,15 Series Trip, Maintained Contacts
9 Series Trip (Current) Aux Switch

Terminal Type:
.110 QC x .020 QC
.080 Dia, Round Solder Turret
.060 Dia, Round Solder Turret
.080 Dia x .020 Flat Q.C.

5. FREQUENCY & TIME DELAY

03 DC 50/60Hz, Switch Only	32 11 DC, 50/60Hz Short
10 DC Instantaneous	34 11 DC, 50/60Hz Medium
12 DC Short	62 50/60Hz Short, High-inrush
14 DC Medium	64 50/60Hz Medium, High-inrush
20 50/60Hz Instantaneous	72 DC, Short, High-inrush
22 50/60Hz Short	74 DC, Medium, High-inrush
24 50/60Hz Medium	92 11 DC, 50/60Hz Short, High-inrush
30 11 DC, 50/60Hz Instantaneous	94 11 DC, 50/60Hz Medium, High-inrush

Voltage			Full Load Amp Rating		General Purpose Amps		Tungsten Lamp Rating		Poles Breaking
Max Rating	Frequency	Phase	Max Amps	Current Coil Rating Code	Max Amps	Choose Current Coil Rating Code	Max Amps	Current Coil Rating Code	
32	DC	-	15	615	25	625	-	-	1
50	DC	-	-	-	7.5	Consult Factory	-	-	1
65	DC	1	15	615	25	625	-	-	2
125	50/60Hz	1	15	615	25	625	15	615	1
250	50/60Hz	1	12	612	-	-	-	-	1
250	50/60Hz	1	15	615	25	625	-	-	2

Notes:

- One actuator is located in the center of each multi-pole breaker.
- For Switch Only circuits, select Current Coil Rating from the above chart.
- One Auxiliary Switch is supplied per breaker. On two-pole breakers, standard Auxiliary Switch mounting is in pole one. Auxiliary Switch option limited to Series Trip & Switch Only circuits, & is not available in single pole illuminated breakers, or Back Connected Screw or Push-in Stud terminals.
- For neon bulb applications at 120VAC @ 47K, 1/4 WATT and for 250VAC applications @ 150K, 1/4 WATT, external resistors must be supplied by customer.
- On Visi-Rockers, Visi portion of rocker cannot be the same color as bezel.
- For LED (DC or rectified AC) applications, LED is mounted in the center of the rocker actuator with electrical characteristics: 100 millicandela at 20mA; Maximum power dissipation = 75mW at 25°C; Maximum forward current = 25mA; Typical forward voltage = 2.1V at 20mA; Typical reverse current = 100uA at 3V. Customer supplies the proper external resistor limiting current to these values.
- Rocker color for LED's and green neon lamp must be clear, smoke gray, white translucent or match color of LED or neon lamp.
- Other colors available. Consult factory.
- TUV 20A, VDE 15A, UL Recognized and CSA Accepted to 30 amps.
- Screw Terminals or Push-in Stud recommended above 20 amps.
- TUV/VDE must have I-O or Dual Legends. Legend required on Visi-Rockers.
- 30 amp rating not available with delay's 30, 32, 34, 92 or 94.
- Screw Terminals are VDE certified only with use of ring terminal attached to wire.
- Terminal code A available with circuit codes A & B only.
- Printed circuit board available with UL recognized approval only.
- Auxiliary switch (flat Q.C.) available with UL recognized approvals only.

6. CURRENT RATING (AMPERES)

CODE	AMPERES	225	0.250	420	2.000	710	10.500
020	0.020	230	0.300	522	2.250	611	11.000
025	0.025	235	0.350	425	2.500	711	11.500
030	0.030	240	0.400	527	2.750	612	12.000
035	0.035	245	0.450	430	3.000	712	12.500
040	0.040	250	0.500	435	3.500	613	13.000
045	0.045	255	0.550	440	4.000	614	14.000
050	0.050	260	0.600	445	4.500	615	15.000
055	0.055	265	0.650	450	5.000	616	16.000
060	0.060	270	0.700	455	5.500	617	17.000
065	0.065	275	0.750	460	6.000	618	18.000
070	0.070	280	0.800	465	6.500	620	20.000
075	0.075	285	0.850	470	7.000	622	22.000
080	0.080	290	0.900	475	7.500	624	24.000
085	0.085	295	0.950	480	8.000	625	25.000
090	0.090	410	1.000	485	8.500	630 11	30.000
095	0.095	512	1.250	490	9.000		
210	0.100	415	1.500	495	9.500		
215	0.150	517	1.750	610	10.000		

7. TERMINAL 12

1 Push-On 0.250 Tab (Q.C.)
 2 Screw 8-32 with Upturned Lugs⁹

3 Screw 8-32 (Bus Type)⁹
 A Push-In Stud¹³
 P Printed Circuit Board¹⁴

8. ROCKER ILLUMINATION

Non-illuminated
Neon⁴
 without resistor, 120VAC/250VAC
LED^{6,7}
 without resistor
 with resistor, 4-8 VDC
 with resistor, 9-16 VDC

A Neon Green Glow⁷
B Red
C Green
D Blue
E Yellow
F Gray
G Amber
H White
J Black
K Black
L Black
M Black

9. ACTUATOR & LEGEND COLOR

Solid Color

Actuator	Legend
1 White	Black
2 Black	White
3 Red	White
4 Green	White
5 Blue	White
6 Yellow	Black
7 Gray	Black
8 Orange	Black

Visi-Rocker⁵
 Visi & Legend (remainder of rocker same color as bezel)

Actuator	Legend
1 White	White
2 Black	Black
3 Red	Red
4 Green	Green
5 Blue	Blue
6 Yellow	Yellow
7 Gray	Gray
8 Orange	Orange

Illuminated⁷

Actuator	Legend
A Clear	White
B Red Transparent	White
C Green Transparent	White
D Amber Transparent	White
E Smoke Gray Transparent	White
F White Translucent	Black

10. LEGEND 10

1 No Legend
 2 ON - OFF Vertical
 3 ON - OFF Horizontal
 4 I - O Vertical

5 I - O Horizontal
 6 Dual Vertical
 7 Dual Horizontal

11. BEZEL COLOR/STYLE 5,8

Color	without Rockerguard	with Rockerguard
White	A	1
Black	B	2
Gray	G	7

12. AGENCY APPROVAL 9,10

C UL 1077 Recognized & CSA Accepted
D VDE Certified to IEC/EN 60934, UL Recognized & CSA Accepted
E TUV Certified to IEC/EN 60934, UL Recognized & CSA Accepted

Configure Complete Part Number >

Browse Standard Parts >

Ordering Scheme

Rocker - UL 489A Listed & 1077 Recognized

Sample Part Number **M A 1 - B - 14 - 620 - 1 - A 1 6 - 2 - J**

Selection 1 2 3 4 5 6 7 8 9 10 11 12

1. SERIES

M

2. ACTUATOR 1

Non-Illuminated single color		Two Color Visi-Rocker		Illuminated single color
A Angled	B Flat	D Indicate ON	E Indicate OFF	F Angled
G Flat				
STYLE	INDICATE - "ON" (CODE-D)	INDICATE - "OFF" (CODE-E)	FLAT (CODES-B&G)	ANGLED (CODES-A&F)
VERTICAL				
HORIZONTAL				

3. POLES

1 One

4. CIRCUIT 2

without Auxiliary Switch	
B Series Trip (Current)	
with Auxiliary Switch, Silver Contacts	Terminal Type:
M Series Trip (Current) Aux Switch	.110 QC x .020 QC
S 3 Series Trip (Current)	.060 Dia, Round Solder Turret
U 3,13 Series Trip, Maintained Contacts	.080 Dia x .020 Flat Q.C.
with Auxiliary Switch, Gold Contacts	
5 3,13 Series Trip, Maintained Contacts	.080 Dia x .020 Flat Q.C.
9 Series Trip (Current) Aux Switch	.110 QC x .020 QC

5. FREQUENCY & TIME DELAY

10 DC Instantaneous	72 DC, Short, High-inrush
12 DC Short	74 DC, Medium, High-inrush
14 DC Medium	

6. CURRENT RATING (AMPERES)

CODE	AMPERES						
020	0.020	225	0.250	420	2.000	710	10.500
025	0.025	230	0.300	522	2.250	611	11.000
030	0.030	235	0.350	425	2.500	711	11.500
035	0.035	240	0.400	527	2.750	612	12.000
040	0.040	245	0.450	430	3.000	712	12.500
045	0.045	250	0.500	435	3.500	613	13.000
050	0.050	255	0.550	440	4.000	614	14.000
055	0.055	260	0.600	445	4.500	615	15.000
060	0.060	265	0.650	450	5.000	616	16.000
065	0.065	270	0.700	455	5.500	617	17.000
070	0.070	275	0.750	460	6.000	618	18.000
075	0.075	280	0.800	465	6.500	620	20.000
080	0.080	285	0.850	470	7.000	622	22.000
085	0.085	290	0.900	475	7.500	624	24.000
090	0.090	295	0.950	480	8.000	625	25.000
095	0.095	410	1.000	485	8.500	630	30.000
210	0.100	512	1.250	490	9.000		
215	0.150	415	1.500	495	9.500		
220	0.200	517	1.750	610	10.000		

7. TERMINAL

1 Push-On 0.250 Tab (Q.C.)	3 Screw 8-32 (Bus Type) 9
2 Screw 8-32 with Upturned Lugs 9	A Push-In Stud 11
	P Printed Circuit Board 12

8. ROCKER ILLUMINATION

Non-illuminated Neon 4	A Neon Green Glow 7
without resistor, 120VAC/250VAC	B Red Green Amber
LED 5,7	D Green Amber
without resistor	E Amber
with resistor, 4-8 VDC	F Amber
with resistor, 9-16 VDC	

9. ACTUATOR & LEGEND COLOR

Solid Color	Actuator	Legend
1	White	Black
2	Black	White
3	Red	White
4	Green	White
5	Blue	White
6	Yellow	Black
7	Gray	Black
8	Orange	Black
Visi-Rocker 6	Visi & Legend (remainder of rocker same color as bezel)	
1	White	
2	Black	
3	Red	
4	Green	
5	Blue	
6	Yellow	
7	Gray	
8	Orange	
Illuminated 7	Actuator	Legend
A	Clear	White
B	Red Transparent	White
C	Green Transparent	White
D	Amber Transparent	White
E	Smoke Gray Transparent	White
F	White Translucent	Black

10. LEGEND 10

1 No Legend	5 I - O Horizontal
2 ON - OFF Vertical	6 Dual Vertical
3 ON - OFF Horizontal	7 Dual Horizontal
4 I - O Vertical	

11. BEZEL COLOR/STYLE 6,8

Color	without Rockerguard	with Rockerguard
White	A	1
Black	B	2
Gray	G	7

12. AGENCY APPROVAL 9,10

J	UL 489A Listed & TUV Certified to IEC/EN 60934
M	UL 1077 Recognized & CSA Accepted
N	TUV Certified to IEC/EN 60934, UL Recognized & CSA Accepted
T	UL 489A Listed

Notes:

- One actuator is located in the center of each multi-pole breaker.
- For Switch Only circuits, select Current Coil Rating from the above chart.
- One Auxiliary Switch is supplied per breaker. On two-pole breakers, standard Auxiliary Switch mounting is in pole one. Auxiliary Switch option limited to Series Trip & Switch Only circuits, & is not available in single pole illuminated breakers, or Back Connected Screw or Push-In Stud terminals.
- For neon bulb applications at 120VAC @ 47K, 1/4 WATT and for 250VAC applications @ 150K, 1/4 WATT, external resistors must be supplied by customer.
- For LED (DC or rectified AC) applications, LED is mounted in the center of the rocker actuator with electrical characteristics as follows: 100 millicandela at 20mA; Maximum power dissipation = 75mW at 25°C; Maximum forward current = 25mA; Typical forward voltage = 2.1V at 20mA; Typical reverse current = 100uA at 3V. Customer supplies the proper external resistor limiting current to these values.
- On Visi-Rocker breakers, Visi portion of rocker cannot be the same color as the bezel.
- Rocker color for LED's and green neon lamp must be clear, smoke gray, white translucent or match color of LED or neon lamp.
- Other colors available. Consult factory.
- UL Recognized, CSA Accepted, UL489A Listed, and TUV Certified to 30 amps. Screw Terminals recommended above 20 amps.
- Polarity Sensitive Construction
- UL489A Listed must have ON-OFF or Dual legends. TUV Certified approvals must have I - O or Dual legends.
- Terminal code A available with circuit codes A & B only.
- Printed circuit board available with UL recognized approval only.
- Auxiliary switch (flat Q.C.) available with UL recognized approvals only.

[Configure Complete Part Number >](#)

[Browse Standard Parts >](#)

Circuit & Terminal Diagrams Rocker

inches [millimeters]

SERIES TRIP

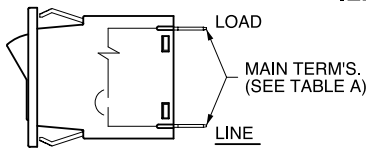

SERIES TRIP W/ ILLUMINATED ROCKER

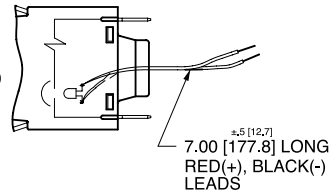

SWITCH ONLY

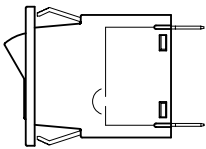

SWITCH ONLY W/ ILLUMINATED ROCKER

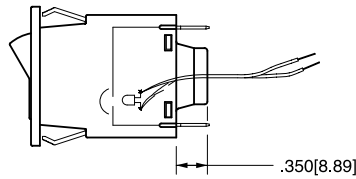

SERIES TRIP W/ AUXILIARY SWITCH

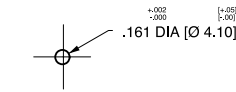
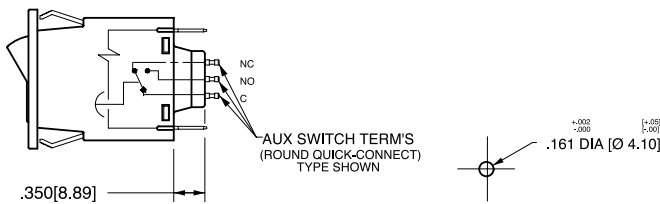

PUSH-IN STUD MATING HOLE

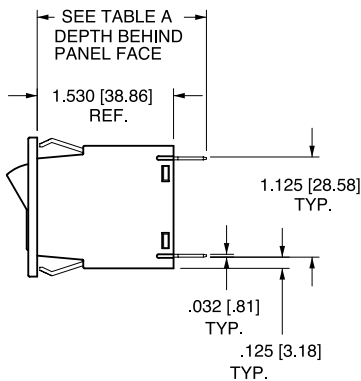

TERMINAL DIMENSIONAL DETAIL

TAB (Q.C.) TERMINAL

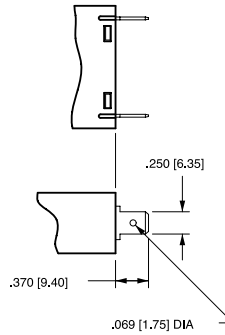

SCREW TERMINAL #8-32 WITH UPTURNED LUGS

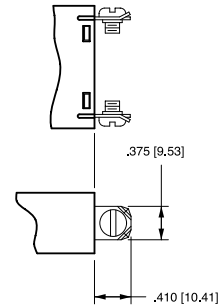

SCREW TERMINAL #8-32 BUS

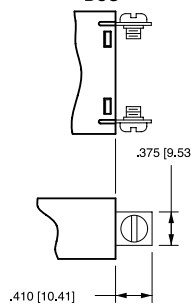

PUSH-IN STUD TERMINAL

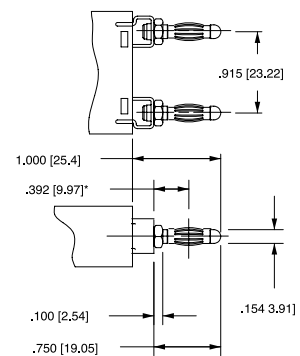

*CENTERLINE OF PUSH-IN STUD CONTACT AREA

AUXILIARY SWITCH TERMINALS

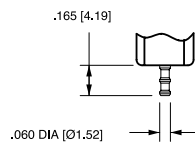

DOUBLE SOLDER TURRET TYPE

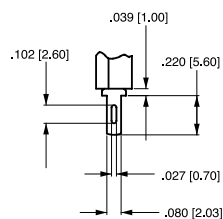

.080 [2.03] X .020 [.51] FLAT QUICK-CONNECT TYPE

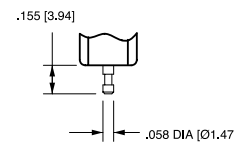

ROUND QUICK-CONNECT TYPE

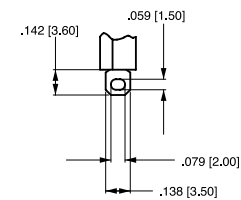

FLAT SOLDER LUG TYPE

*AVAILABLE THROUGH SPECIAL CATALOG PART NUMBER

.110 QC

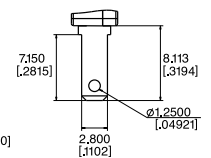

TABLE - A		
TERMINAL DESCRIPTION		DEPTH BEHIND PANEL FACE
MAIN	TAB (Q.C.)	1.900 [48.26]
	SCREW (#8-32)**	1.940 [49.28]
	PUSH-IN STUD	2.530 [64.26]
*AUX. SWITCH	DOUBLE SOLDER TURRET TYPE	2.045 [51.94]
	ROUND Q.C. TYPE	2.035 [51.69]
	FLAT QUICK CONNECT	2.139 [54.33]
	FLAT SOLDER LUG	2.022 [51.36]

* AUX. SWITCH IS NOT AVAILABLE ON SINGLE POLE ILLUMINATED UNITS. WHEN CALLED FOR ON MULTI-POLE UNITS, ONLY ONE AUX. SWITCH IS NORMALLY SUPPLIED, MOUNTED AS SHOWN ON CLA-8003.

** RECOMMENDED TIGHTENING TORQUE 12-15 IN LBS [1.4-2.7 NM]

Notes:

- 1 Tolerance ± 0.020 [.51] unless otherwise specified.
- 2 Schematic shown represents current trip circuit.

Dimensional Specs Rocker

inches [millimeters]

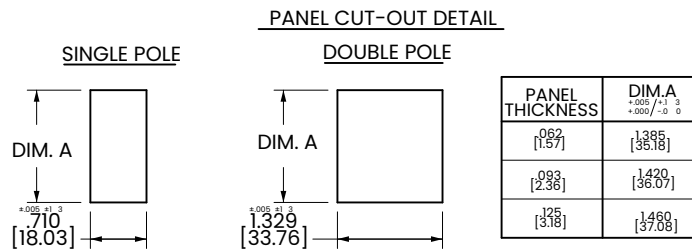
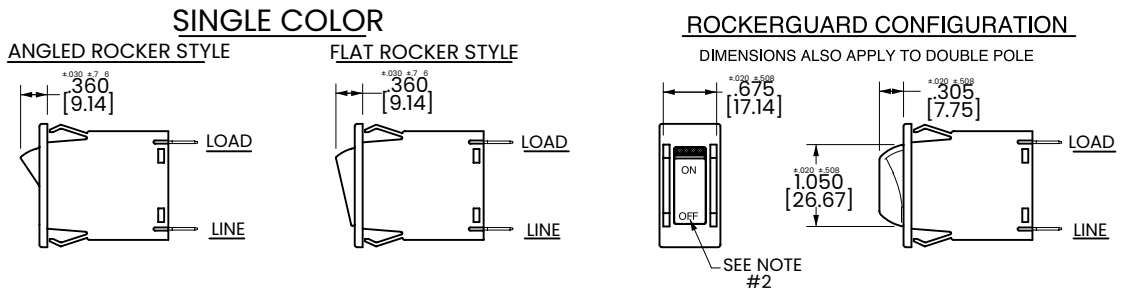
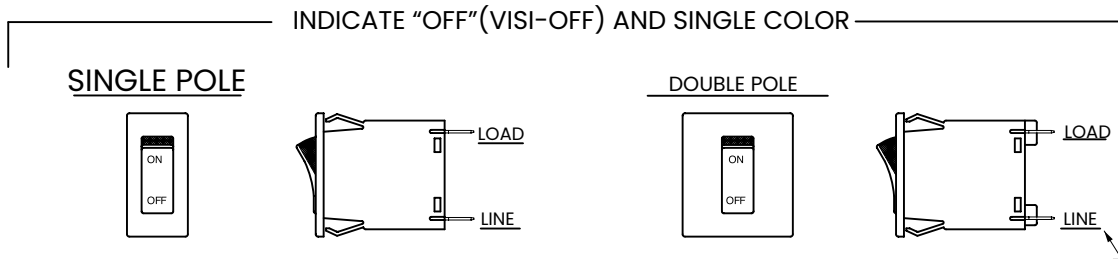
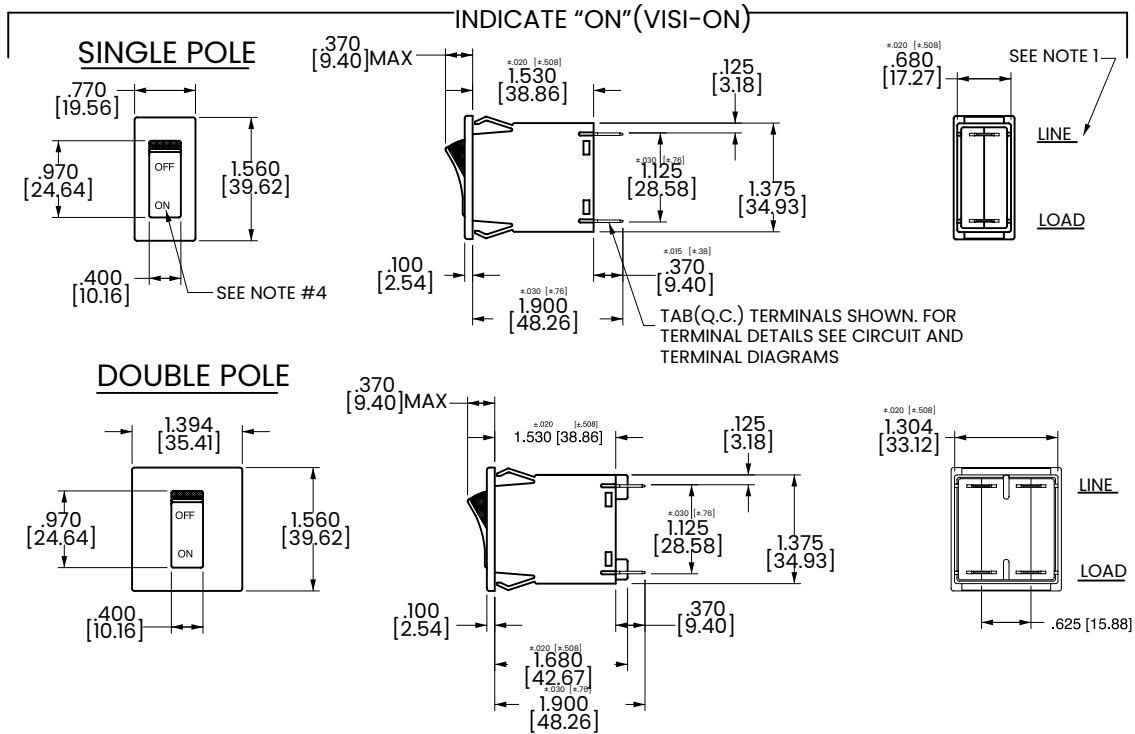

- Notes:
- 1 Dimensions apply to all variations shown. Notice that circuit breaker line & load terminal orientation on indicate OFF is opposite of indicate ON.
 - 2 I-O, ON-OFF or dual legends available for vertical or horizontal mounting. For pole orientation with horizontal legend, rotate front view clockwise 90°.
 - 3 Tolerance ± 0.20 [.51] unless otherwise specified.

Supplementary Diagrams Rocker

ONE POLE

SINGLE POLE/ROCKER BREAKERS SHOWN WITH DOUBLE SOLDER TURRET AND ROUND QC AUX.SWITCH TERMINALS

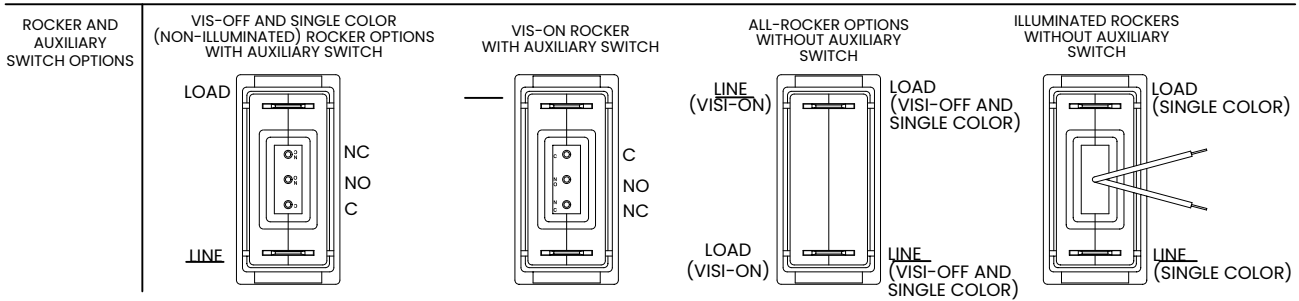

SINGLE POLE/ROCKER BREAKERS SHOWN WITH FLAT QC AND FLAT SOLDER LUG AUX.SWITCH TERMINALS

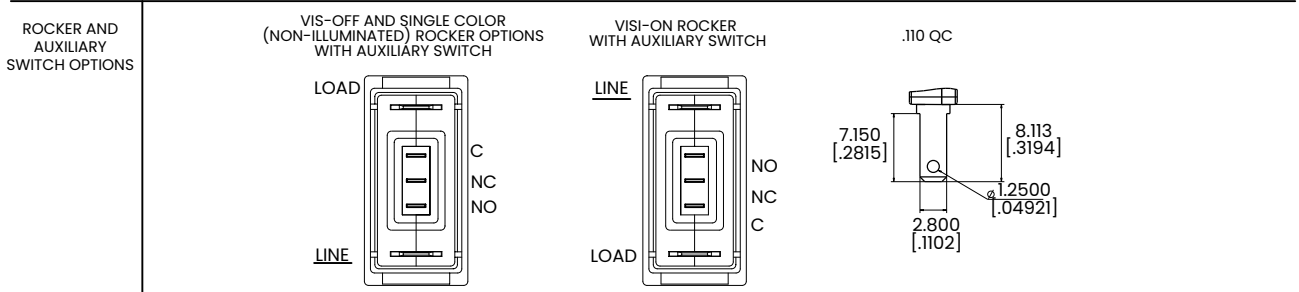

TWO POLE

DOUBLE POLE/ROCKER BREAKERS SHOWN WITH DOUBLE SOLDER TURRET AND ROUND QC AUX.SWITCH TERMINALS

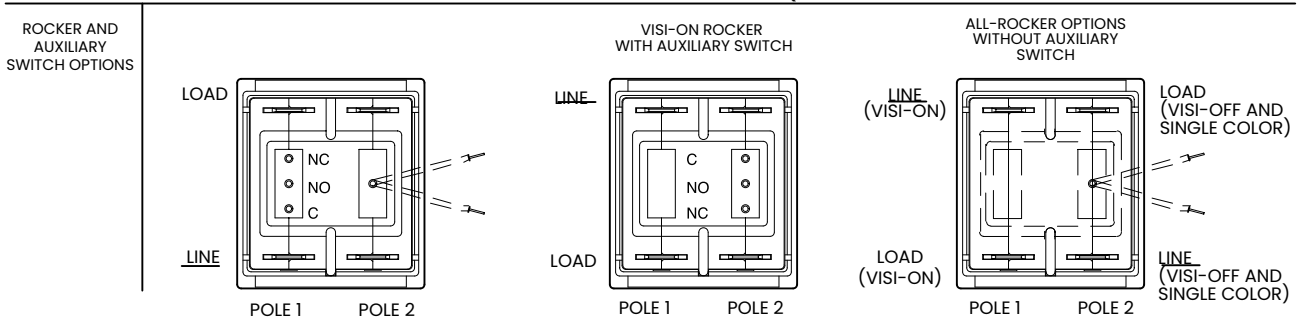

DOUBLE POLE/ROCKER BREAKERS SHOWN WITH FLAT QC AND FLAT SOLDER LUG AUX.SWITCH TERMINALS

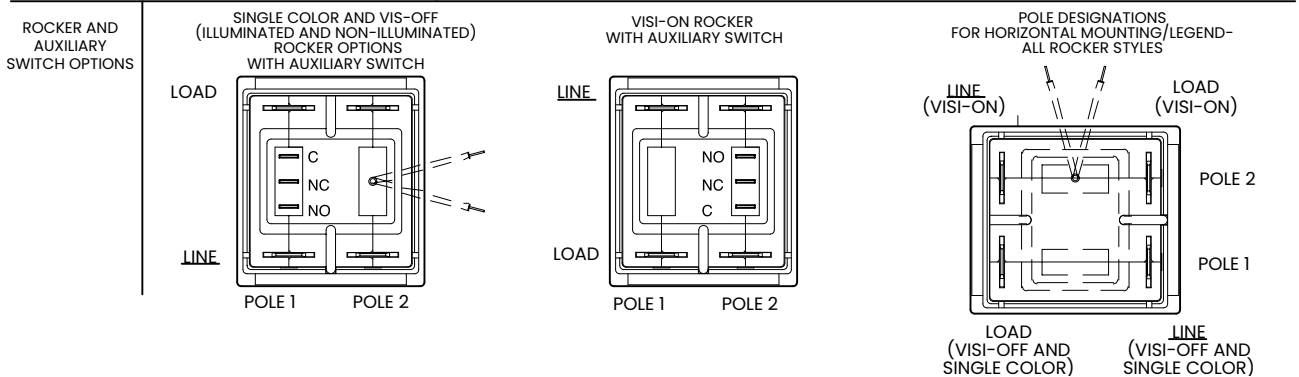

Ordering Scheme

Handle/Pushbutton - UL 1077 Recognized



Sample Part Number **M M 1 - B - 34 - 260 - 1 - 1 B B - C - B**



Selection 1 2 3 4 5 6 7 8 9 10 11 12



1. SERIES

M

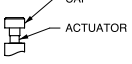
2. ACTUATOR 1,4

Handle
M Paddle  **N** Baton 

Push Button
T Push-Pull  **U** Push To Reset 

Push Button with Snap-In Mounting
V Push-Pull  **W** Push To Reset 

3. POLES

1 One 2 Two

4. CIRCUIT 2

without Auxiliary Switch
A Switch Only (no coil), Maintained Contacts
B Series Trip (Current)

with Auxiliary Switch, Silver Contacts **Terminal Type:**
M Series Trip (Current) Aux Switch .110 QC x .020 QC
P 3 Switch Only, Maintained Contacts .060 Dia, Round Solder Turret
R 3,12 Switch Only, Maintained Contacts .080 Dia x .020 Flat Q.C.
S 3 Series Trip (Current) .060 Dia, Round Solder Turret
U 3,12 Series Trip, Maintained Contacts .080 Dia x .020 Flat Q.C.

with Auxiliary Switch, Gold Contacts
3 3,12 Switch Only, Maintained Contacts .080 Dia x .020 Flat Q.C.
5 3,12 Series Trip, Maintained Contacts .080 Dia x .020 Flat Q.C.
9 Series Trip (Current) Aux Switch .110 QC x .020 QC

5. FREQUENCY & TIME DELAY

03 DC 50/60Hz, Switch Only	32 ⁸ DC, 50/60Hz Short
10 DC Instantaneous	34 ⁸ DC, 50/60Hz Medium
12 DC Short	62 50/60Hz Short, High-inrush
14 DC Medium	64 50/60Hz Medium, High-inrush
20 50/60Hz Instantaneous	72 DC, Short, High-inrush
22 50/60Hz Short	74 DC, Medium, High-inrush
24 50/60Hz Medium	92 ⁸ DC, 50/60Hz Short, High-inrush
30 ⁸ DC, 50/60Hz Instantaneous	94 ⁸ DC, 50/60Hz Medium, High-inrush

Voltage			Full Load Amp Rating		General Purpose Amps		Tungsten Lamp Rating		Poles Breaking
Max Rating	Frequency	Phase	Max Amps	Current Coil Rating Code	Max Amps	Choose Current Coil Rating Code	Max Amps	Current Coil Rating Code	
32	DC	-	15	615	25	625	-	-	1
50	DC	-	-	-	7.5	Consult Factory	-	-	1
65	DC	1	15	615	25	625	-	-	2
125	50/60Hz	1	15	615	25	625	15	615	1
250	50/60Hz	1	12	612	-	-	-	-	1
250	50/60Hz	1	15	615	25	625	-	-	2

Notes:

- One actuator is located in the center of each multi-pole breaker. Actuator codes V & W limited to single pole breakers only.
- Switch Only circuits are not available with Push-To-Reset actuators. For Switch Only circuits, select Current Coil Rating from the above chart.
- One Auxiliary Switch is supplied per breaker. On two-pole breakers, standard Auxiliary Switch mounting is in pole one. Auxiliary Switch option limited to Series Trip and Switch Only circuits. Not available with back connect screw or push-in stud terminals.
- Actuator color is only visible in the OFF position on Push-Pull actuators.
- All units except snap-in mounting have one hex nut installed on bushing for use behind the panel.
- Other colors available. Consult factory.
- TUV 20A, VDE 15A. UL Recognized and CSA Accepted to 30 amps. Screw Terminals or Push-in Stud recommended above 20 amps.
- 30 amp rating not available with delay's 30, 32, 34, 92 or 94.
- Screw Terminals are VDE certified only with use of ring terminal attached to wire.
- Terminal code A available with circuit codes A & B only.
- Printed circuit board available with UL recognized approval only.
- Auxiliary switch (flat Q.C.) available with UL recognized approvals only.

6. CURRENT RATING (AMPERES)

CODE	AMPERES						
020	0.020	225	0.250	420	2.000	710	10.500
025	0.025	230	0.300	522	2.250	611	11.000
030	0.030	235	0.350	425	2.500	711	11.500
035	0.035	240	0.400	527	2.750	612	12.000
040	0.040	245	0.450	430	3.000	712	12.500
045	0.045	250	0.500	435	3.500	613	13.000
050	0.050	255	0.550	440	4.000	614	14.000
055	0.055	260	0.600	445	4.500	615	15.000
060	0.060	265	0.650	450	5.000	616	16.000
065	0.065	270	0.700	455	5.500	617	17.000
070	0.070	275	0.750	460	6.000	618	18.000
075	0.075	280	0.800	465	6.500	620	20.000
080	0.080	285	0.850	470	7.000	622	22.000
085	0.085	290	0.900	475	7.500	624	24.000
090	0.090	295	0.950	480	8.000	625	25.000
095	0.095	410	1.000	485	8.500	630 ⁸	30.000
210	0.100	512	1.250	490	9.000		
215	0.150	415	1.500	495	9.500		
220	0.200	517	1.750	610	10.000		

7. TERMINAL 9

1 Push-On 0.250 Tab (Q.C.)	3 Screw 8-32 (Bus Type) ⁷
2 Screw 8-32 with Upturned Lugs ⁷	A Push-In Stud ¹⁰
	P Printed Circuit Board ¹¹

8. ROCKER ILLUMINATION

Gloss Handle	Push-Button	Actuator Color
1	A	White
2	B	Black
3	C	Red
4	D	Green
5	E	Blue
6	F	Yellow
8	H	Orange

9. ACTUATOR & LEGEND COLOR 4,5

	Handle	Push-Button
No outer Panel Hardware	A	1
Knurled Nut		
Bright nickel	B	2
Bright nickel with locking ring	C	
Black	D	
Black with locking ring	E	
Panel Dress Nut		
Bright nickel	F	
Bright nickel with locking ring	G	
Black	H	
Black with locking ring	J	

10. LEGEND

Handle Actuator Legend Plate (Actuator Styles M & N)
A No Legend Plate
B ON - OFF Vertical
C ON - OFF Horizontal
D I - O Vertical
E I - O Horizontal

Push-Pull Actuator Button Cap (Actuator Styles T & V)
1 No Marking
2 Rated Amps Horizontal
3 Rated Amps Line Side Down
4 Rated Amps Line Side Up

Push-to-Reset Actuator Button (Actuator Styles U & W)
1 No Marking

11. BUSHING COLOR 6

B Black

12. AGENCY APPROVAL 7

C	UL 1077 Recognized & CSA Accepted
D	VDE Certified to IEC/EN 60934, UL Recognized & CSA Accepted
E	TUV Certified to IEC/EN 60934, UL Recognized & CSA Accepted

Ordering Scheme

Handle/Pushbutton - UL 489A Listed & 1077 Recognized







Sample Part Number **M M 1 - B - 14 - 620 - 1 - 1 B B - B - J**

Selection 1 2 3 4 5 6 7 8 9 10 11 12

1. SERIES

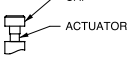
M

2. ACTUATOR 1,5

Handle M Paddle 	N Baton 
Push Button T Push-Pull 	U Push To Reset 
Push Button with Snap-In Mounting V Push-Pull 	W Push To Reset 

3. POLES

1 One

4. CIRCUIT 2

without Auxiliary Switch B Series Trip (Current)	Terminal Type: .110 QC x .020 QC
with Auxiliary Switch, Silver Contacts M Series Trip (Current) Aux Switch	.060 Dia, Round Solder Turret
S ³ Series Trip (Current)	.080 Dia x .020 Flat Q.C.
U ^{3,11} Series Trip, Maintained Contacts with Auxiliary Switch, Gold Contacts	.080 Dia x .020 Flat Q.C.
5 ^{3,11} Series Trip, Maintained Contacts	.110 QC x .020 QC
9 Series Trip (Current) Aux Switch	

5. FREQUENCY & TIME DELAY

03 DC 50/60Hz, Switch Only	32 DC, 50/60Hz Short
10 DC Instantaneous	34 DC, 50/60Hz Medium
12 DC Short	62 50/60Hz Short, High-inrush
14 DC Medium	64 50/60Hz Medium, High-inrush
20 50/60Hz Instantaneous	72 DC, Short, High-inrush
22 50/60Hz Short	74 DC, Medium, High-inrush
24 50/60Hz Medium	92 DC, 50/60Hz Short, High-inrush
30 DC, 50/60Hz Instantaneous	94 DC, 50/60Hz Medium, High-inrush

6. CURRENT RATING (AMPERES)

CODE	AMPERES						
020	0.020	225	0.250	420	2.000	710	10.500
025	0.025	230	0.300	522	2.250	611	11.000
030	0.030	235	0.350	425	2.500	711	11.500
035	0.035	240	0.400	527	2.750	612	12.000
040	0.040	245	0.450	430	3.000	712	12.500
045	0.045	250	0.500	435	3.500	613	13.000
050	0.050	255	0.550	440	4.000	614	14.000
055	0.055	260	0.600	445	4.500	615	15.000
060	0.060	265	0.650	450	5.000	616	16.000
065	0.065	270	0.700	455	5.500	617	17.000
070	0.070	275	0.750	460	6.000	618	18.000
075	0.075	280	0.800	465	6.500	620	20.000
080	0.080	285	0.850	470	7.000	622	22.000
085	0.085	290	0.900	475	7.500	624	24.000
090	0.090	295	0.950	480	8.000	625	25.000
095	0.095	410	1.000	485	8.500	630	30.000
210	0.100	512	1.250	490	9.000		
215	0.150	415	1.500	495	9.500		
220	0.200	517	1.750	610	10.000		

7. TERMINAL

1 Push-On 0.250 Tab (Q.C.)	3 Screw 8-32 (Bus Type) ⁴
2 Screw 8-32 with Upturned Lugs ⁴	A Push-in Stud ⁹
	P Printed Circuit Board ¹⁰

8. ROCKER ILLUMINATION

Gloss Handle	Push-Button	Actuator Color
1	A	White
2	B	Black
3	C	Red
4	D	Green
5	E	Blue
6	F	Yellow
8	H	Orange

9. ACTUATOR & LEGEND COLOR 5,6

	Handle	Push-Button
No outer Panel Hardware	A	1
Knurled Nut		
Bright nickel	B	2
Bright nickel with locking ring	C	
Black	D	
Black with locking ring	E	
Panel Dress Nut		
Bright nickel	F	
Bright nickel with locking ring	G	
Black	H	
Black with locking ring	J	

10. LEGEND

Handle Actuator Legend Plate (Actuator Styles M & N)	
A	No Legend Plate
B	ON - OFF Vertical
C	ON - OFF Horizontal
D	I - O Vertical
E	I - O Horizontal
Push-Pull Actuator Button Cap (Actuator Styles T & V)	
1 ¹²	No Marking
2	Rated Amps Horizontal
3	Rated Amps Line Side Down
4	Rated Amps Line Side Up
Push-to-Reset Actuator Button (Actuator Styles U & W)	
1	No Marking

11. BUSHING COLOR 7

B Black

12. AGENCY APPROVAL 8

J	UL 489A Listed, TUV Certified to IEC/EN 60934
M	UL 1077 Recognized, CSA Accepted
N	UL Recognized, TUV Certified to IEC/EN 60934
T	UL 489A Listed

- One actuator is located in the center of each multi-pole breaker. Actuator codes V & W limited to single pole breakers only.
- Switch Only circuits are not available with Push-To-Reset actuators. For Switch Only circuits, select Current Coil Rating from the above chart.
- One Auxiliary Switch is supplied per breaker. On two-pole breakers, standard Auxiliary Switch mounting is in pole one. Auxiliary Switch option limited to Series Trip and Switch Only circuits.
- Not available with Back Connected Screw or Push-in Stud terminals.
- Screw terminals or Push-in Stud recommended above 20 amps.
- Actuator color is only visible in the OFF position on Push-Pull actuators.
- All units have one hex nut installed on bushing for use behind the panel.
- Other colors available. Consult factory.
- UL Recognized, CSA Accepted and UL Listed to 30 amps. Polarity Sensitive Construction
- Terminal code A available with circuit codes A & B only.
- Printed circuit board available with UL recognized approval only.
- Auxiliary switch (flat Q.C.) available with UL recognized approvals only.
- Push-Pull actuator style is available with the rated amps marked on the cap in white. For no marking, choose code "1".

Circuit & Terminal Diagrams Handle

inches [millimeters]

SERIES TRIP

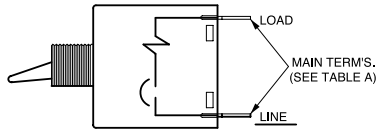

SWITCH ONLY

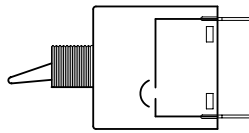

SERIES TRIP W/ AUXILIARY SWITCH

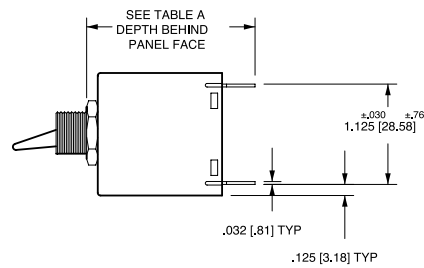
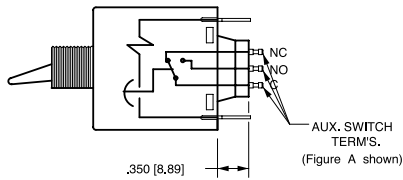

TABLE A		
	TERMINAL DESCRIPTION	DEPTH BEHIND PANEL FACE *
MAIN	TAB (Q.C)	1.890 [48.00]
	SCREW (#8-32)	1.930 [49.03]
	PUSH-IN STUD	2.520 [64.00]
AUX. ** SWITCH	DOUBLE SOLDER TURRET TYPE	2.035 [51.69]
	ROUND Q.C TYPE	2.025 [51.44]
	FLAT QUICK-CONNECT	2.129 [54.08]
	FLAT SOLDER LUG	2.012 [51.10]

*DEPTH INCLUDES BEHIND PANEL HEX NUT AS SUPPLIED ON ALL UNITS.

**WHEN CALLED FOR ON MULTI-POLE UNITS, ONLY ONE AUX. SWITCH IS NORMALLY SUPPLIED, MOUNTED AS SHOWN IN FIG. A

TERMINAL DIMENSIONAL DETAIL

TAB (Q.C.) TERMINAL

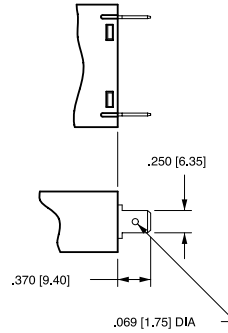

SCREW TERMINAL #8-32 WITH UPTURNED LUGS

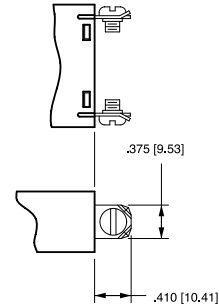

SCREW TERMINAL #8-32 BUS

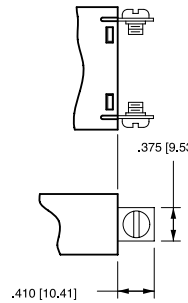

PUSH-IN STUD TERMINAL

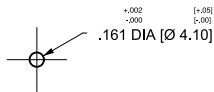
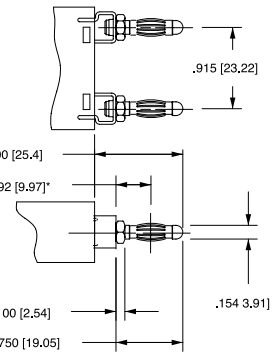

*CENTERLINE OF PUSH-IN STUD CONTACT AREA

PUSH-IN STUD MATING HOLE

AUXILIARY SWITCH TERMINALS

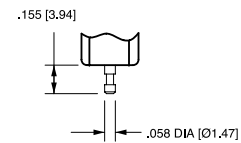
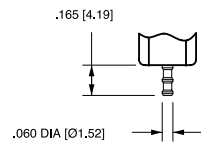

DOUBLE SOLDER TURRET TYPE

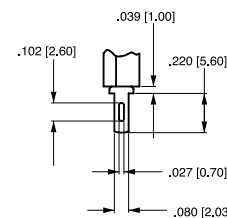

ROUND QUICK-CONNECT TYPE

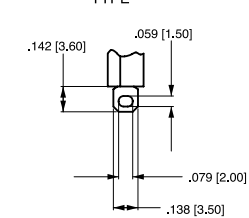

.110 QC

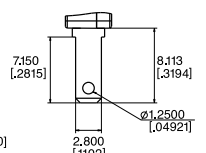

.080 [2.03] X .020 [5.1] FLAT QUICK-CONNECT TYPE

FLAT SOLDER LUG TYPE

*AVAILABLE THROUGH SPECIAL CATALOG PART NUMBER

MULTI-POLE IDENTIFICATION SCHEME

SOLDER TURRET AND ROUND QC AUX SWITCH TERMINALS

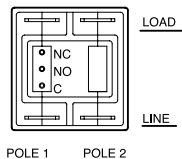

FIG. A

FLAT QC AND SOLDER LUG AUX SWITCH TERMINALS

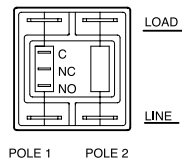

FIG. B

Notes:

1 Tolerance ±.020 [.51] unless otherwise specified.

PC Terminal Diagrams Handle

inches [millimeters]

HANDLE TYPE SHOWN WITHOUT AUX. SWITCH

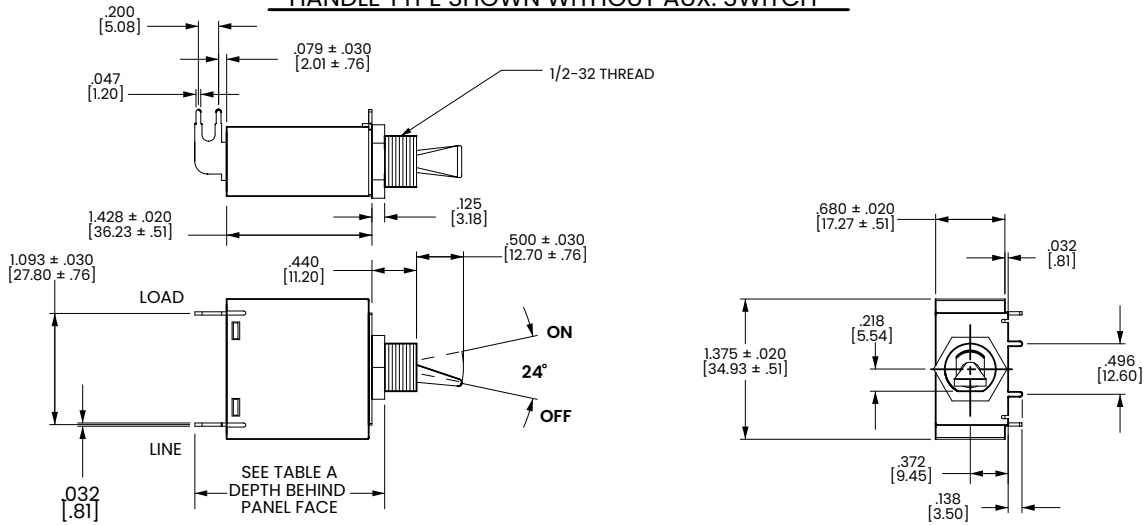

P.C. FOOTPRINT

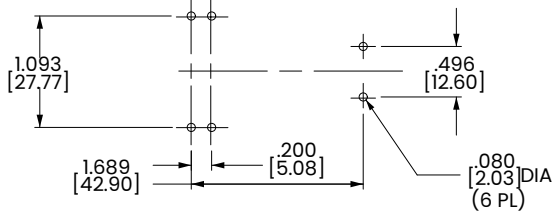

P.C. TERMINAL

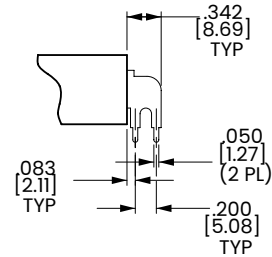

HANDLE TYPE SHOWN WITH AUX. SWITCH

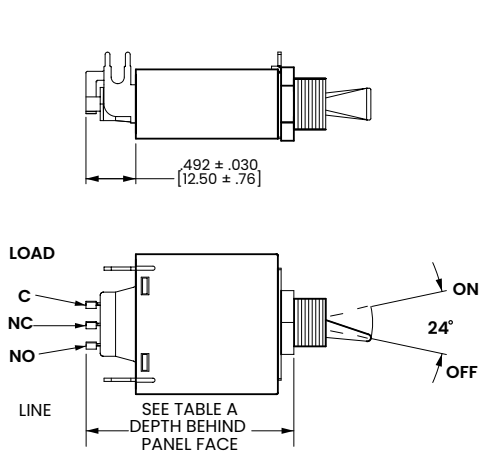

PANEL HARDWARE

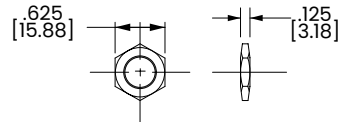

HEX NUT

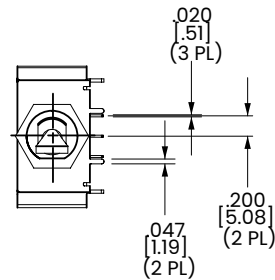

P.C. FOOTPRINT

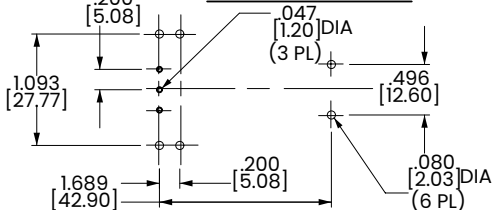

TABLE A		
	TERMINAL DESCRIPTION	DEPTH BEHIND PANEL FACE *
	PRINTED CIRCUIT BOARD	1.957 [49.70]
AUX. SWITCH	PRINTED CIRCUIT BOARD	2.449 [62.20]

*DEPTH INCLUDES BEHIND PANEL HEX NUT AS SUPPLIED ON ALL UNITS

Notes:

1 Tolerance ±.020 [.51] unless otherwise specified.

Dimensional Specs Handle

inches [millimeters]

PADDLE ACTUATOR STYLE

SINGLE POLE

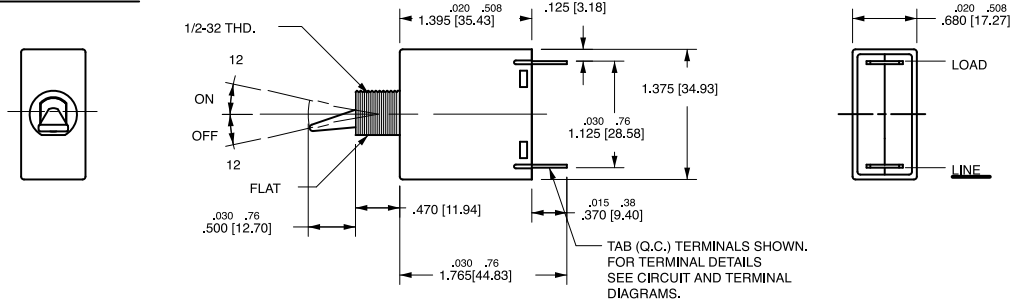

DOUBLE POLE

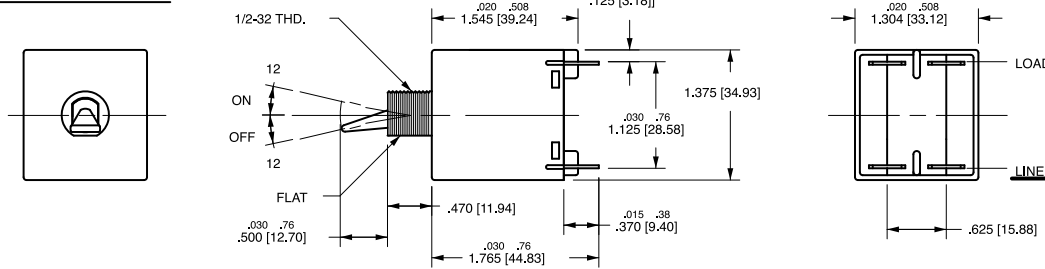

BATON ACTUATOR STYLE

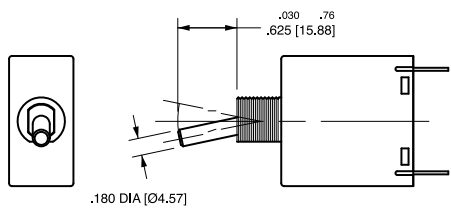

MOUNTING DETAILS

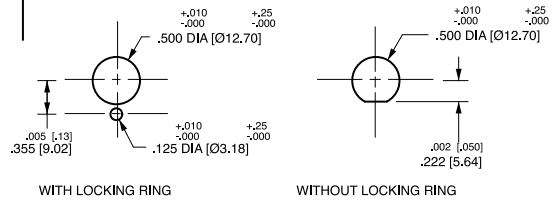

LEGEND PLATES

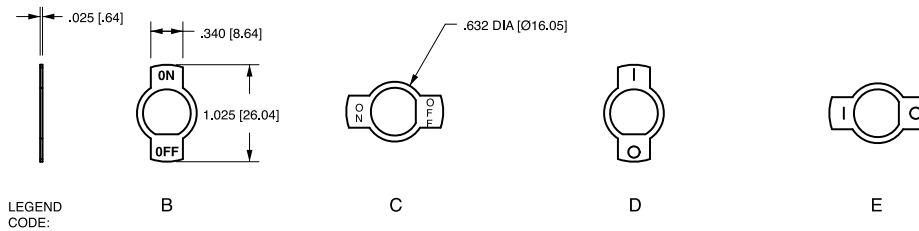

PANEL HARDWARE

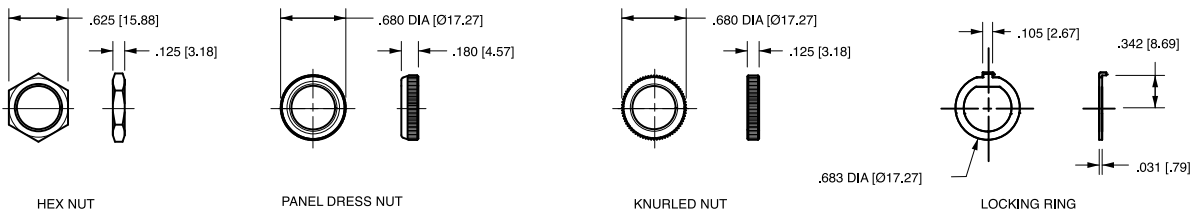

Notes:
1 Tolerance ± 0.020 [.51] unless otherwise specified.

Circuit & Terminal Diagrams Pushbutton

inches [millimeters]

SERIES TRIP

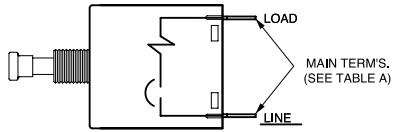

SWITCH ONLY

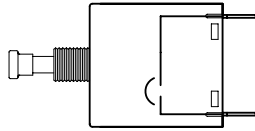

SERIES TRIP W/ AUXILIARY SWITCH

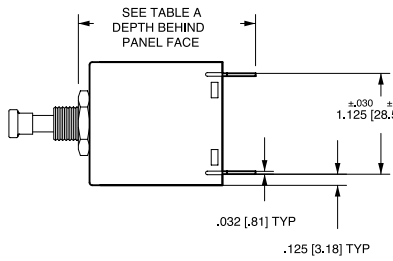
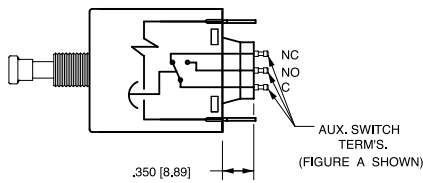

TABLE A		
TERMINAL DESCRIPTION		DEPTH BEHIND PANEL FACE *
MAIN	TAB (Q.C.)	1.952 [49.57]
	SCREW (#8-32)	1.992 [50.60]
	PUSH-IN STUD	2.582 [65.58]
AUX. ** SWITCH	DOUBLE SOLDER TURRET TYPE	2.097 [53.26]
	ROUND Q.C. TYPE	2.087 [53.01]
	FLAT QUICK-CONNECT	2.191 [55.65]
	FLAT SOLDER LUG	2.074 [52.68]

*DEPTH INCLUDES BEHIND PANEL HEX NUT AS SUPPLIED ON ALL UNITS.

** WHEN CALLED FOR ON MULTI-POLE UNITS, ONLY ONE AUX. SWITCH IS NORMALLY SUPPLIED, MOUNTED AS SHOWN IN FIG. A

MULTI-POLE IDENTIFICATION SCHEME

SOLDER TURRET AND ROUND QC AUX SWITCH TERMINALS

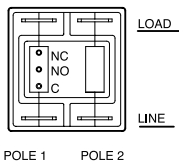

FIG. A

FLAT QC AND SOLDER LUG AUX SWITCH TERMINALS

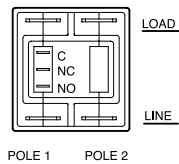
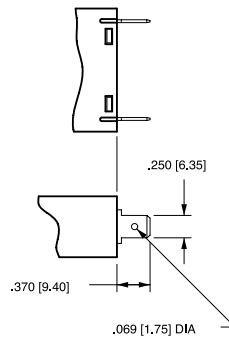

FIG. B

TERMINAL DIMENSIONAL DETAIL

TAB (Q.C.) TERMINAL



SCREW TERMINAL #8-32 WITH UPTURNED LUGS

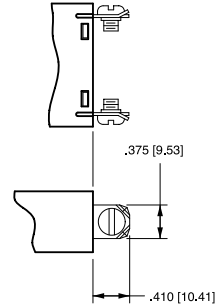

SCREW TERMINAL #8-32 BUS

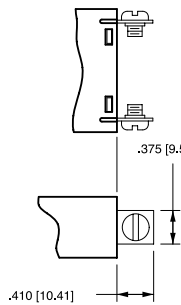

PUSH-IN STUD TERMINAL

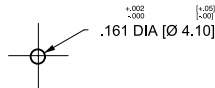
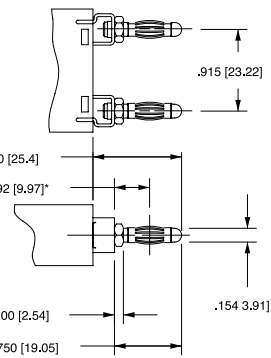

PUSH-IN STUD MATING HOLE

*CENTERLINE OF PUSH-IN STUD CONTACT AREA

AUXILIARY SWITCH TERMINALS

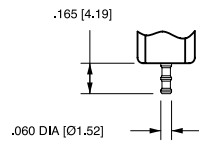

DOUBLE SOLDER TURRET TYPE

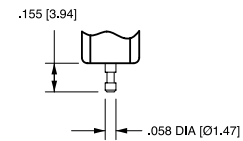

ROUND QUICK-CONNECT TYPE

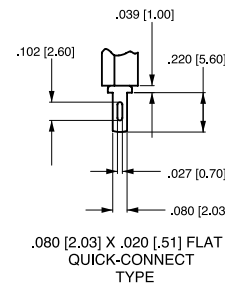

.110 QC

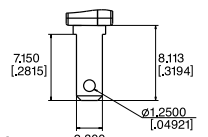
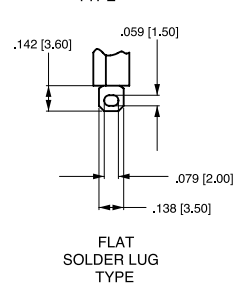

*AVAILABLE THROUGH SPECIALL CATALOG PART NUMBER

Notes:

1 Tolerance ±.020 [.51] unless otherwise specified.

Dimensional Specs Pushbutton

inches [millimeters]

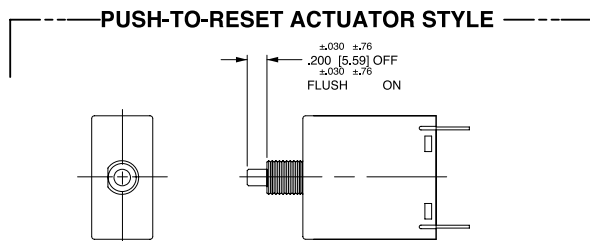
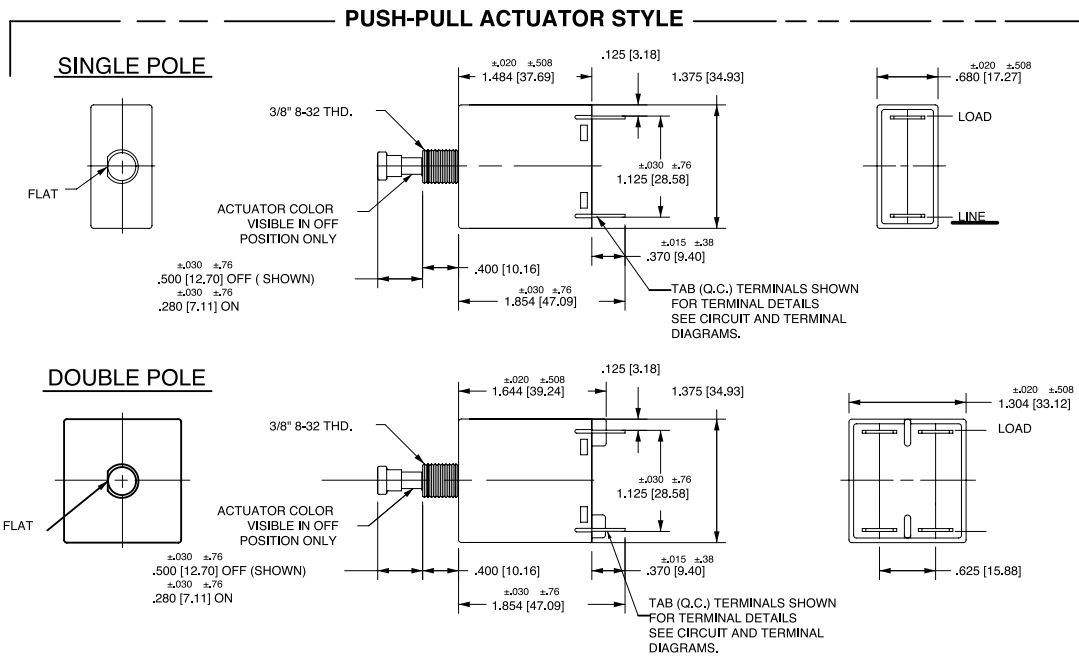

MOUNTING DETAILS

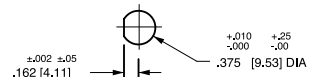

**PUSH-PULL,
PUSH TO RESET**

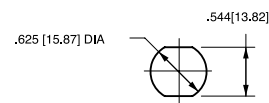
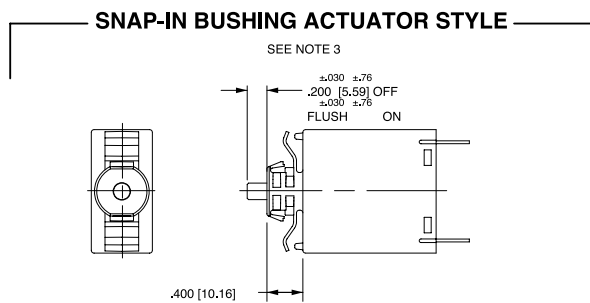

SNAP-IN BUSHING

PANEL HARDWARE



HEX NUT

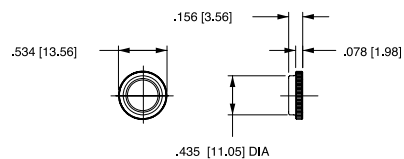

PANEL DRESS NUT

BUTTON MARKING ORIENTATION (PUSH-PULL ONLY)

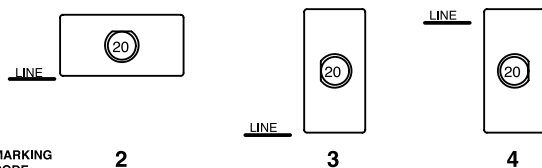

- Notes:
- 1 All dimensions are in inches [millimeters].
 - 2 Available with Push-Pull or Push-to-Reset Actuators

MS-Series

Hydraulic-Magnetic Circuit Breaker

PRODUCT WEBPAGE

request sample, configure part, watch video

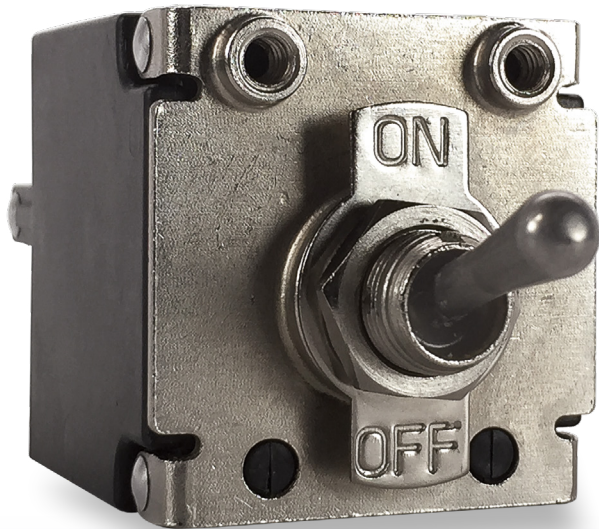
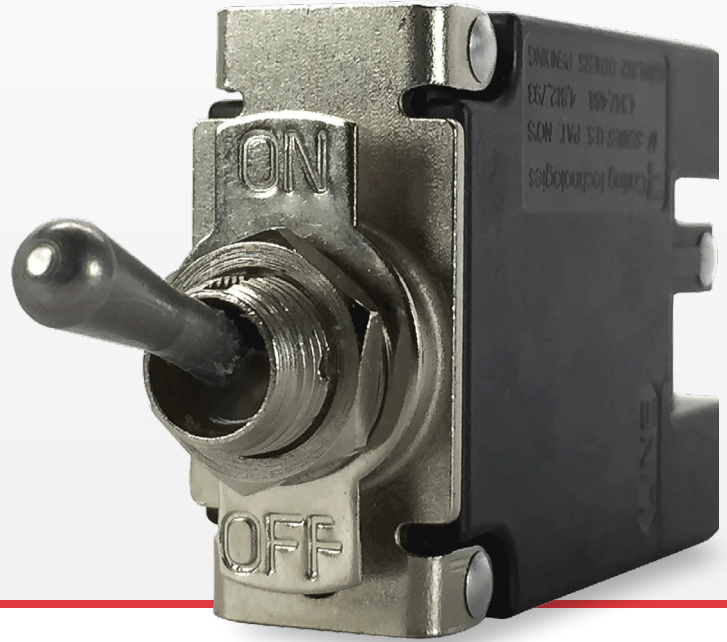

Sealed Metal Toggle

The MS-Series hydraulic-magnetic circuit breaker with sealed metal toggle actuator is compact in size, but ruggedly designed to meet IP68 requirements and MIL-PRF-39019F ingress protection when panel mounted. Additionally, it is MIL-PRF-55629 and MIL STD 202 compliant, making it ideal for COTS military applications, crucial communication equipment and other mission critical components. MS-Series breakers are available as a one to three pole configuration with ratings from 0.02 to 30 amps, up to 240VAC/65VDC and 3,000 amps max IC.

1-3

Poles

0.20-30

Amps

120/250

VAC

65

VDC

Typical Applications

- Vehicles
- Communication Equipment
- Generators
- Power Supplies

Design Features

SEALS

IP68 Designed and tested to comply with MIL-PRF-39019F Ingress Protection

COMPACT SIZE

Max performance in compact size: 0.20-30 Amps; 65 VDC, 240 VAC 120/240 VAC

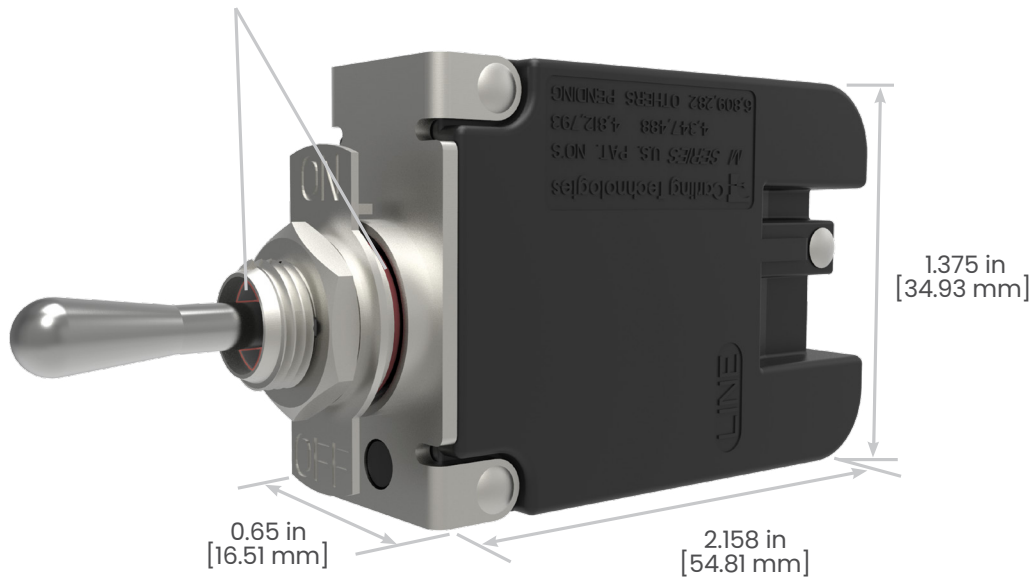

TERMINAL BARRIERS

Meet UL 1077 Spacing Requirements

OPTIONAL AUXILIARY SWITCH

Provides Breaker Status Indication

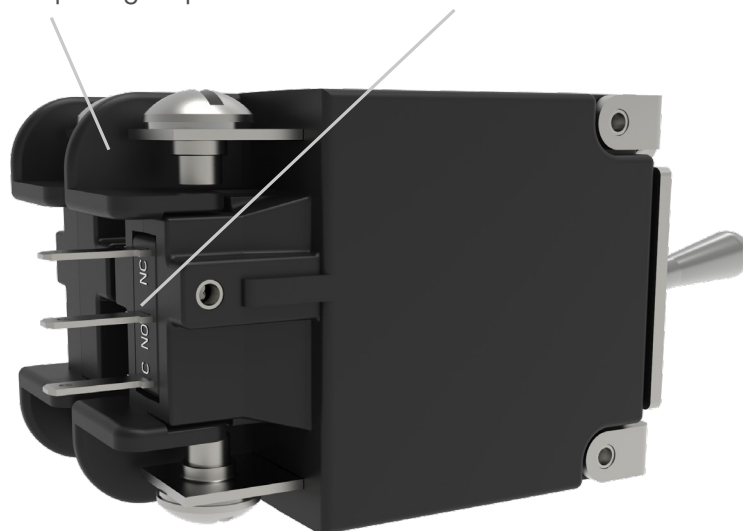

Tech Specs

Electrical

Current Ratings	.02 - 30 Amps
Voltage Ratings	65VDC, 240VAC, 120/240VAC
Short Circuit Rating	See Table A
Auxiliary Switch Rating	5A @ 125VAC, 3A @ 32VDC, .1A @ 125VAC, 32VDC
Dielectric Strength	ULCSA 1500V, 50/60 Hz for one minute between all electrically isolated terminals.
Insulation Resistance	Minimum of 100 Megohms @ 500VDC
Time Delay Impedance	See delay curve

RESISTANCE, IMPEDANCE VALUES
from Line to Load Terminals
(Values Based on Series Trip Circuit Breaker)

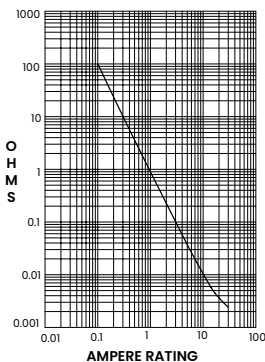

CURRENT (AMPS)	TOLERANCE (%)
0.20 - 30.0	25

Physical

Number of Poles	1-3 poles
Weight	Approximately 1.8 oz (50 G) per pole
Dimensions	See dimensional specs

Agency Certification

UL Standard 1077
cRUus Standard C22.2
TUV Certified

Time Delay Specs

To view all hydraulic-magnetic circuit breaker time delay values, please visit www.carlingtech.com/sites/default/files/documents/Carling-HM-CB-Time-Delays.pdf

Tables Table A: Lists UL & cRUus Configuration & Performance Capabilities

Component Supplementary Protectors									
Circuit Configuration	Voltage			Current Rating		Short Circuit Capacity (Amps) ¹			
	Max Rating	Frequency	Phase	General Purpose Amps	Poles Breaking	UL / cRUus		TUV	
						U1	U3	Inc ²	Icn
Series	65	DC	---	0.02 - 30	1	3000	300	3000	300
	240	50 / 60	1	0.02 - 30	1, 2	2000	300	3000	300
	120 / 240	50 / 60	1	0.02 - 30	2 or 3	2000	300	3000	300

Notes:

¹ Short Circuit Current Rating (SC) Codes – The short-circuit current rating, followed by a letter and number designating the test conditions and any calibration following the short-circuit test as defined below:

U - Indicates that the short circuit test was performed without a series fuse

1 - Indicates that a re-calibration was not performed as part of the short circuit testing

3 - Indicates that the protector has proven to be suitable for further use after the short circuit test

Re-calibration, dielectric strength and voltage withstand tests were performed after the short circuit testing

2 - Inc rating obtained with a 50 Amp type gL fuse

Mechanical

Current Ratings	10,000 ON-OFF operations @ 6 per minute; with rated Current & Voltage.
Trip Free	Trips on short circuit and overload, even when the actuator is forcibly held in the "On" position.
Trip Indication	The operating handle moves positively to the "Off" position when a short circuit or overload causes the circuit breaker to trip.

Environmental

Designed in accordance with requirements of specification MIL PRF-55629 & MIL-STD-202G as follows:

Shock	Withstands 100G's, 6ms, saw tooth while carrying rated current per Method 213, Condition I. Instantaneous curves tested at 80% of rated current.
Vibration	Withstands 0.060" excursion from 10-55 Hz, and 10G's 55-500 Hz, at rated current per Method 204C, Test Condition A. Instantaneous curves tested at 80% of rated current.
Salt Spray	Method 101, Condition A (90-95% RH @ 5% NaCl Solution, 96 hrs)
Moisture Resistance	Method 106G
Thermal Shock	Method 107D, Condition A (Five cycles @ -55°C to +25°C to +85°C to +25°C)
Operating Temperature	-40°C to +85°C
Ingress Protection Level	MIL-PRF-55629C when mounted in panel.
Other	Materials used in this product are non-nutrient to fungus growth.

Ordering Scheme

Sample Part Number

M S 1 - B - 14 - 615 - C - 1 C B - A - 0A A

Selection

1 2 3 4 5 6 7 8 9 10 11 12 13

1. SERIES

M

2. ACTUATOR ¹

S Sealed Toggle

3. POLES

1 One 2 Two 3 Three

4. CIRCUIT

A Switch Only (no coil)^{1,2}
 B Series Trip (current)
 M Series Trip (current) Aux switch .110 QC x 0.20 QC (silver contacts)
 9 Series Trip (current) Aux switch .110 QC x 0.20 QC (gold contacts)

5. FREQUENCY & DELAY

03 DC, 50/60Hz, Switch Only ¹	32 DC, 50/60Hz Short
10 DC, Instantaneous	34 DC, 50/60Hz Medium
12 DC, Short	62 50/60Hz Short, High-inrush ⁴
14 DC, Medium	64 50/60Hz Medium, High-inrush ⁴
20 50/60Hz Instantaneous	72 DC, Short, High-inrush ⁴
22 50/60Hz Short	74 DC, Medium, High-inrush ⁴
24 50/60Hz Medium	92 DC, 50/60Hz Short, High-inrush ⁴
30 DC, 50/60Hz Instantaneous	94 DC, 50/60Hz Medium, High-inrush ⁴

6. CURRENT RATING (AMPERES)

CODE	AMPERES						
220	0.200	295	0.950	460	6.00	614	14.00
225	0.250	410	1.00	465	6.50	615	15.00
230	0.300	512	1.25	470	7.00	616	16.00
235	0.350	415	1.50	475	7.50	617	17.00
240	0.400	517	1.75	480	8.00	717	17.50
245	0.450	420	2.00	485	8.50	618	18.00
250	0.500	522	2.25	490	9.00	619	19.00
255	0.550	425	2.50	495	9.50	620	20.00
260	0.600	527	2.75	610	10.00	622	22.00
265	0.650	430	3.00	710	10.50	624	24.00
270	0.700	435	3.50	611	11.00	625	25.00
275	0.750	440	4.00	711	11.50	630	30.00
280	0.800	445	4.50	612	12.00		
285	0.850	450	5.00	712	12.50		
290	0.900	455	5.50	613	13.00		

Notes:

- 1 Series code "A" only available with delay code "03"
- 2 Only available when tied to a protected pole
- 3 Requires a 2 or 3 pole device
- 4 Only available without agency approvals (Approval Code A)

[Configure Complete Part Number >](#)

[Browse Standard Parts >](#)

7. TERMINAL

1 Push-On 0.250 Tab (QC)
 2 Screw 8-32 (Upturned Lugs)
 3 Screw 8-32 (Bus Type)
 C Screw Terminal M4 (Upturned Lugs)
 E Screw Terminal M4 (Bus Type)
 L Solder Lug

8. ACTUATOR & MARKING COLOR

1 Dull Metallic

9. FRONT PANEL HARDWARE

A No Outer Panel Hardware
 B Hex Nut, Nickel Plated
 C Hex Nut, Nickel Plated with Locking Ring
 F Panel Dress Nut, Nickel Plated
 G Panel Dress Nut, Nickel Plated with Locking Ring

10. LEGEND PLATE

A No Legend Plate
 B On-Off Vertical
 C On-Off Horizontal
 D I-O Vertical
 E I-O Horizontal
 F Dual Vertical
 G Dual Horizontal

11. BUSHING COLOR

A Nickel Plated / Multipole Version

12. VOLTAGE CODE

0A 65 VDC
 0D 240 VAC
 0C 120/240 VAC³
 0N 65 VDC / 120/240 VAC³
 17 65 VDC / 240 VAC

13. AGENCY APPROVAL

A Without approvals
 B UL Recognized
 C UL & cRUus Recognized
 E TUV Certified, UL Recognized, cRUus Recognized
 U TUV Certified

Dimensional Specs

inches [millimeters]

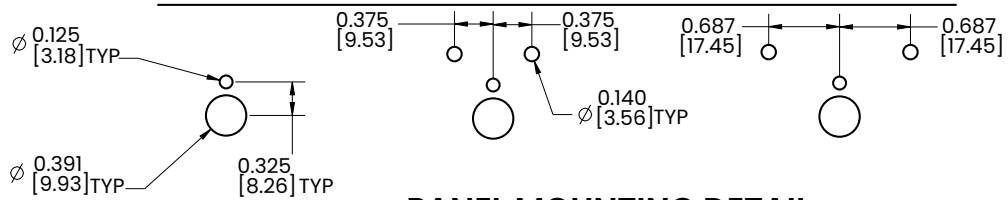
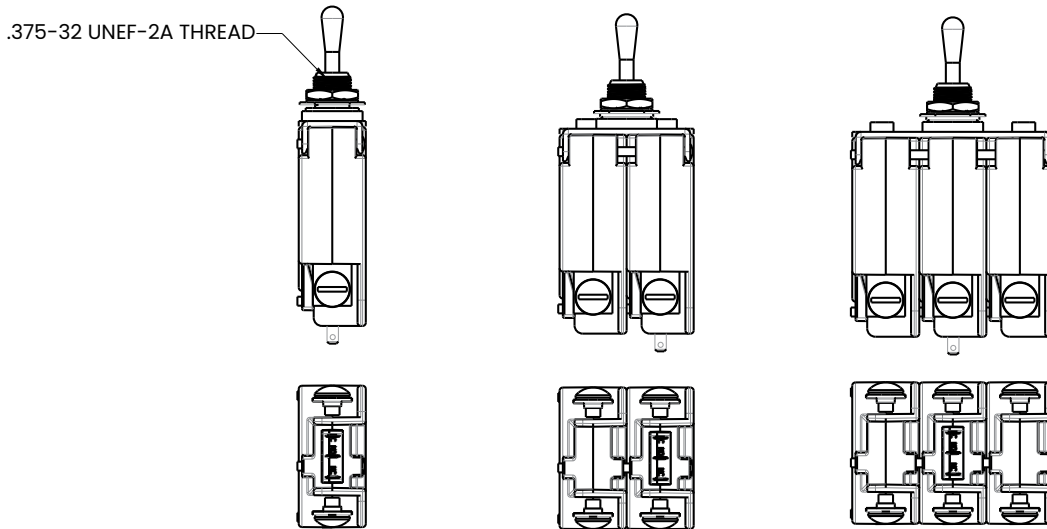
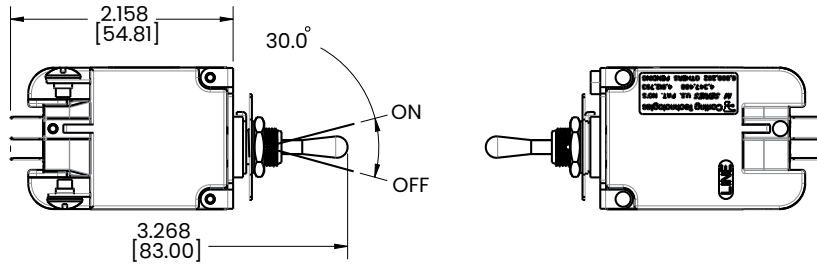
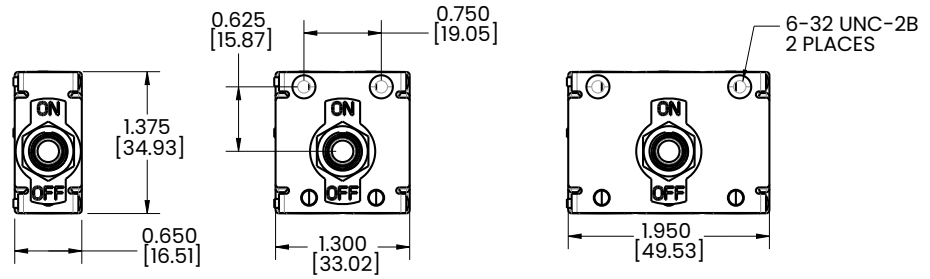

**PANEL MOUNTING DETAIL
PANEL THICKNESS 0.125" TO 0.156"**

Notes:
1 Tolerance ± 0.020 [51] unless otherwise specified.

N-Series

Hydraulic-Magnetic Circuit Breaker

PRODUCT WEBPAGE

request sample, configure part, watch video



Low Profile Datacom/Telecom Applications

The N-Series is a full-featured hydraulic-magnetic circuit breaker packaged in an innovative low profile design to meet the smaller size requirements of datacom/telecom power distribution units and rack systems. Its features include easy access line and load terminals with UL 489 compliant sliding terminal barriers, an optional current transformer capable of sensing current down to a level of 1%, and a patented flush rocker actuator with push-to-reset guard to protect against inadvertent actuation. The N-Series is available as a one or two pole configuration with ratings from 1 to 30 amps, up to 240VAC for one pole or 120/240VAC for two poles with a max IC of 22,000 amps.

1-2 Poles **1-30** Amps **120/240** VAC **22,000 Amps**
 Max Interrupting Capacity

Typical Applications

- Power Distribution Units
- Data Servers
- Data Storage

Design Features

CURRENT TRANSFORMER

Remote current sensing via Molex® connector

GRIDS (5x)

Arc deionizing splitter plates that increase arc voltage for quick interrupt

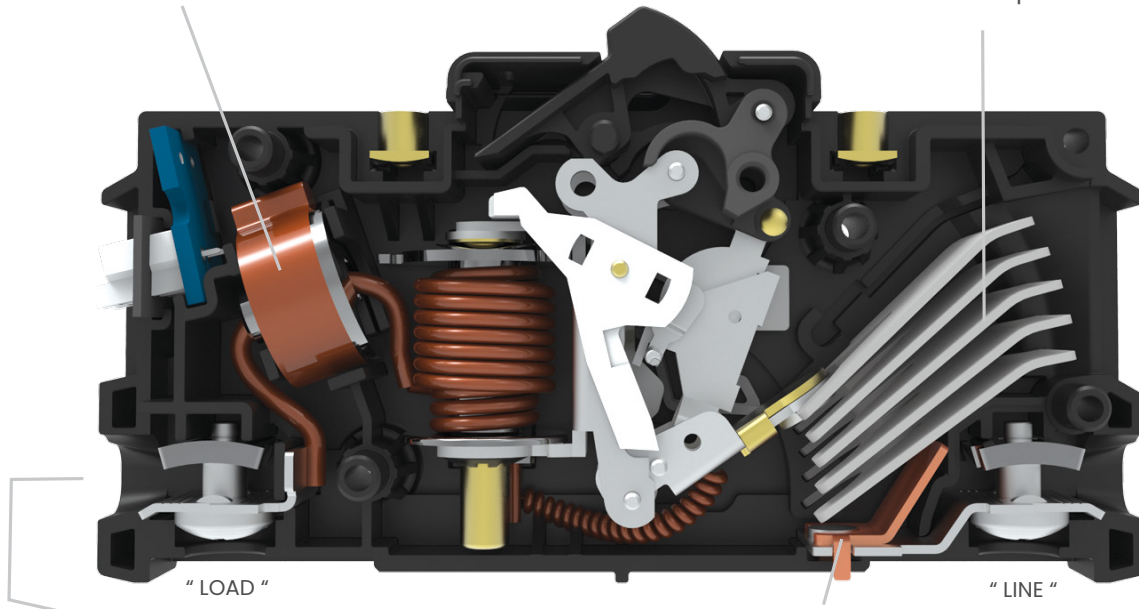

TERMINAL

Allows for easy hook-up of wires on both sides of the breaker

LOWER ARC RUNNER

Motivates arc off of the stationary contact

SLIDING TERMINAL BARRIERS

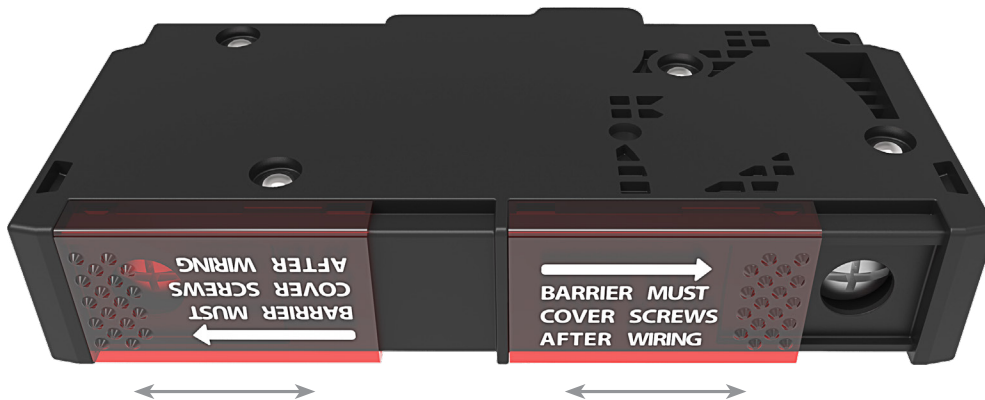

Tech Specs

Electrical

Dielectric Strength UL, CSA-1960V 50/60 Hz for one minute between all electrically isolated terminals. Comply with the 8mm spacing and 3750V 50/60 Hz dielectric requirements from hazardous voltage to operator accessible surfaces and between main circuits of adjacent poles per Publications EN 60950 and VDE 0805

Current Ratings Integrated current transformer. Measurement range: 1-30 Amps. Voltage output: 10mV per Amp according to the formula below:
 $2(\text{Amp}) \leq I \leq 30(\text{Amp})$
 $V = 0.01 \times I \pm 2\%$
 (with current metering codes 1 or 2)
 $V = 0.01 \times I \pm 1\%$
 (with current metering codes 3 or 4)

$$\left| \frac{\frac{V}{I} - \frac{V_{10}}{I_{10}}}{\frac{V_{10}}{I_{10}}} \right| \leq 0.85\%$$

Where V=CT output in volts
 V_{10} =CT output in volts with $I=I_{10}=10$ (A); I =primary current in amperage (50/60 Hz). Phase shift between primary current and CT output is $0.25 \pm 0.25^\circ$. Maximum crest factor of primary current is 1.73. R1 shall be integrated in the breaker. R2 and R3 are provided by end user and external to the breaker. Connection: below Load Terminal. 2-pin connector, Molex® 35362-0250. Mating Connector housing – Molex® PN35507-0200.
 (Current metering is available on AC rated devices only)

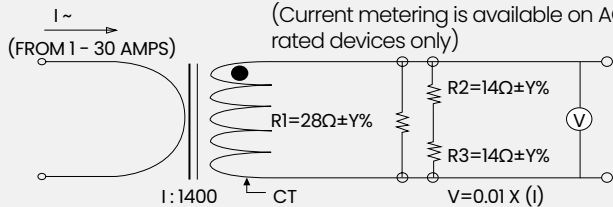

Note: When current metering code is 1 or 2; Y to equal 1.0
 When current metering code is 3 or 4; Y to equal 0.1

Impedance	See next page
Insulation Resistance	Minimum of 100 Megohms @ 500VDC
Overload	50 operations @ 600% of rated current for AC rated devices
Interrupt Capacity	See table A

Mechanical

Current Ratings	10,000 "On-Off" operations @ 6 per minute; with rated current & voltage
Trip Free	Trips on overload even when actuator is forcibly held in the "On" position
Trip Indication	The operating actuator moves positively to the "Off" position when an overload causes the breaker to trip

Environmental

Environmental	MIL-PRF-55629 and MIL-STD-202G
Operating Temp.	-40°C to +85°C
Vibration	Withstands 0.06" excursion from 10-55 Hz and 10Gs 55-500 Hz at rated current per MIL-PRF-55629 and MIL-STD-202G, Method 204D, Test Condition A. Instantaneous and ultra-short curves tested at 90% of rated current
Shock	MWithstands 50 Gs, 6 ms saw tooth while carrying rated current per MIL-PRF-55629 and MIL-STD-202G, Method 213B, test condition "I". Instantaneous and ultra short curves tested at 90% of rated current
Thermal Shock	MIL-PRF-55629 and MIL-STD-202G, Method 107G, Condition A (5-cycles at -55°C to +25°C to +85°C to +25°C
Moisture Resistance	MIL-PRF-55629 and MIL-STD-202G, Method 106G, i.e., Ten 24-hour cycles at +25°C to +65°C, 80-98% RH
Salt Spray	Method 101, Condition A (90-95% RH @ 5% NaCl Solution, 96hrs)

Physical

Number of Poles	1 - 2 poles
Termination	Wire ready and touch proof wire clamp (See Figure 1). Accepts up to (2) #10 AWG wires per terminal. Designed for use with solid, stranded and flexible stranded wires, with or without ferrule or pin terminals. Also accepts straight fork and flanged fork terminals.
Termination Torque	15-20 in-lbs (Line & Load terminals)
Termination Barrier	Integral sliding barrier to comply with spacing requirements (See figure 1)
Mounting	Threaded Insert: #6-32 UNC-2B, or M3X0.5-6H B ISO
Insert Termination Torque	7-9 in-lbs
Actuator	Rocker, with or without guard (See figures 1, 2, and 4)
Internal Circuit Config.	Series Trip
Materials	Housing - Glass Filled Polyester Rocker - Nylon Line/Load Terminals - Copper Alloy; Bright Acid Tin Plated
Weights	~107 grams (~3.76 ounces) per pole
Standard Color	Housing - Black Rocker - Several (See ordering scheme for colors)

Tech Specs

Electrical Tables

Table A: Voltage and Current Ratings

Electrical Ratings								
Voltage	Current (Amps)	Number of Poles	Interrupt Capacity (Amps)					
			UL 489		EN60947-2			
			1-20 A	21-30 A	1-20 A		21-30 A	
					Icu	Ics	Icu	Ics
120/240 VAC	1 - 30	2	22000	5000	10000	5000	10000	5000
240 VAC	1 - 20	1	10000	N/A	10000	5000	5000	5000

Electrical: Impedance / Resistance

RESISTANCE, IMPEDANCE VALUES Across Line and Load Terminals

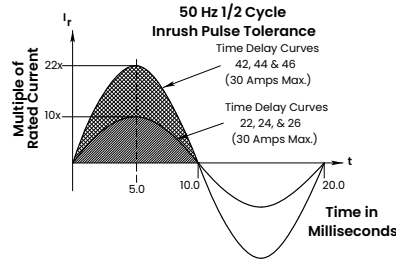
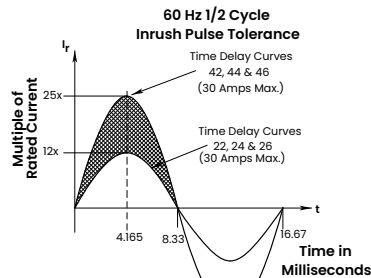
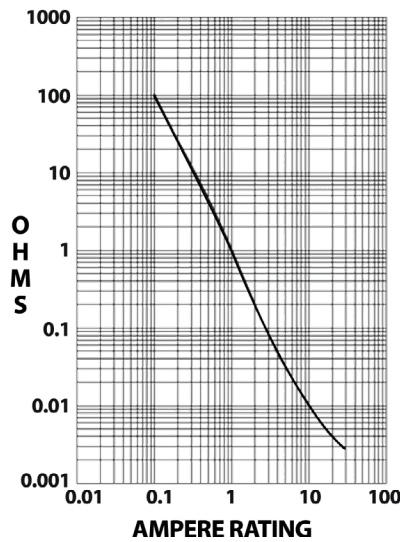

CURRENT (AMPS)	TOLERANCE (%)
0.10 - 5.0	+/- 15
5.1 - 30.0	+/- 25

Agency Approvals

UL489, cUL, TUV EN60947-2

Time Delay Specs

To view all hydraulic-magnetic circuit breaker time delay values, please visit www.carlingtech.com/sites/default/files/documents/Carling-HM-CB-Time-Delays.pdf

Ordering Scheme

Sample Part Number **N 1 1 - B 0 - 24-620 - 1 2 1 - D G**

Selection 1 2 3 4 5 6 7 8 9 10 11 12

1. SERIES

N N-Series Circuit Breaker

2. ACTUATOR

- 1 Single Color Low Profile Rocker, Vertical Legend
- 2 Single Color Low Profile Rocker, Horizontal Legend
- 3 Single Color Push To Reset Low Profile Rocker, Vertical Legend
- 4 Single Color Push To Reset Low Profile Rocker, Horizontal Legend

3. POLES

- 1 One
- 2 Two

4. CIRCUIT

B Series Trip (Current)

5. CURRENT METERING

- 0 Without Current Transformer
- 1¹ Integrated Current Transformer, +/- 2%, 1 per unit
- 2 Integrated Current Transformer, +/- 2%, 1 per pole
- 3^{2,5} Integrated Current Transformer, +/- 1%, 1 per unit
- 4⁵ Integrated Current Transformer, +/- 1%, 1 per pole

6. FREQUENCY & TIME DELAY

- | | |
|-------------------------|---------------------------------|
| 21 50/60 Hz Ultra Short | 42 50/60 Hz Short, High-inrush |
| 22 50/60 Hz Short | 44 50/60 Hz Medium, High-inrush |
| 24 50/60 Hz Medium | 46 50/60 Hz Long, High-inrush |
| 26 50/60 Hz Long | |

7. CURRENT RATING (AMPERES)

CODE	AMPERES	CODE	AMPERES	CODE	AMPERES	CODE	AMPERES
410	1.00	440	4.00	490	9.00	615	15.00
512	1.25	445	4.50	495	9.50	616	16.00
415	1.50	450	5.00	610	10.00	617	17.00
517	1.75	455	5.50	710	10.50	618	18.00
420	2.00	460	6.00	611	11.00	620	20.00
522	2.25	465	6.50	711	11.50	622	22.00
425	2.50	470	7.00	612	12.00	624	24.00
527	2.75	475	7.50	712	12.50	625	25.00
430	3.00	480	8.00	613	13.00	630	30.00
435	3.50	485	8.50	614	14.00		

8. TERMINAL

1 Screw Terminal

9. ACTUATOR COLOR & LEGEND

Actuator Color	I-O	ON-OFF	Dual	Legend Color
White	A	B	1	Black
Black	C	D	2	White
Red	F	G	3	White
Green	H	J	4	White
Blue	K	L	5	White
Yellow	M	N	6	Black
Gray	P	Q	7	Black
Orange	R	S	8	Black

10. MOUNTING

- 1 6-32 x .195 inches Threaded Inserts
- 2 ISO M3 x 5 mm Threaded Inserts

11. APPLICATION RATING

- C 120/240 VAC (2 Pole only)
- D² 240 VAC

12. AGENCY APPROVAL

- A Without Approvals
- G UL 489 Listed
- U³ TUV Certified, IEC 60947-2
- 3⁴ UL 489 Listed, TUV Certified

Notes:

- 1 On multi pole units one current transformer is supplied on the actuator pole
- 2 Available up to 20 amps
- 3 TUV approval requires dual (I-O, ON-OFF) markings
- 4 Approval Code "3" requires Dual (I-O, ON-OFF) markings on rocker.
- 5 +/-1% tolerance only available when used with +/-0.1% tolerance external burden resistor.

[Configure Complete Part Number >](#)

[Browse Standard Parts >](#)

Dimensional Specs

inches [millimeters]

Figure 1. N-Series 1-Pole Construction

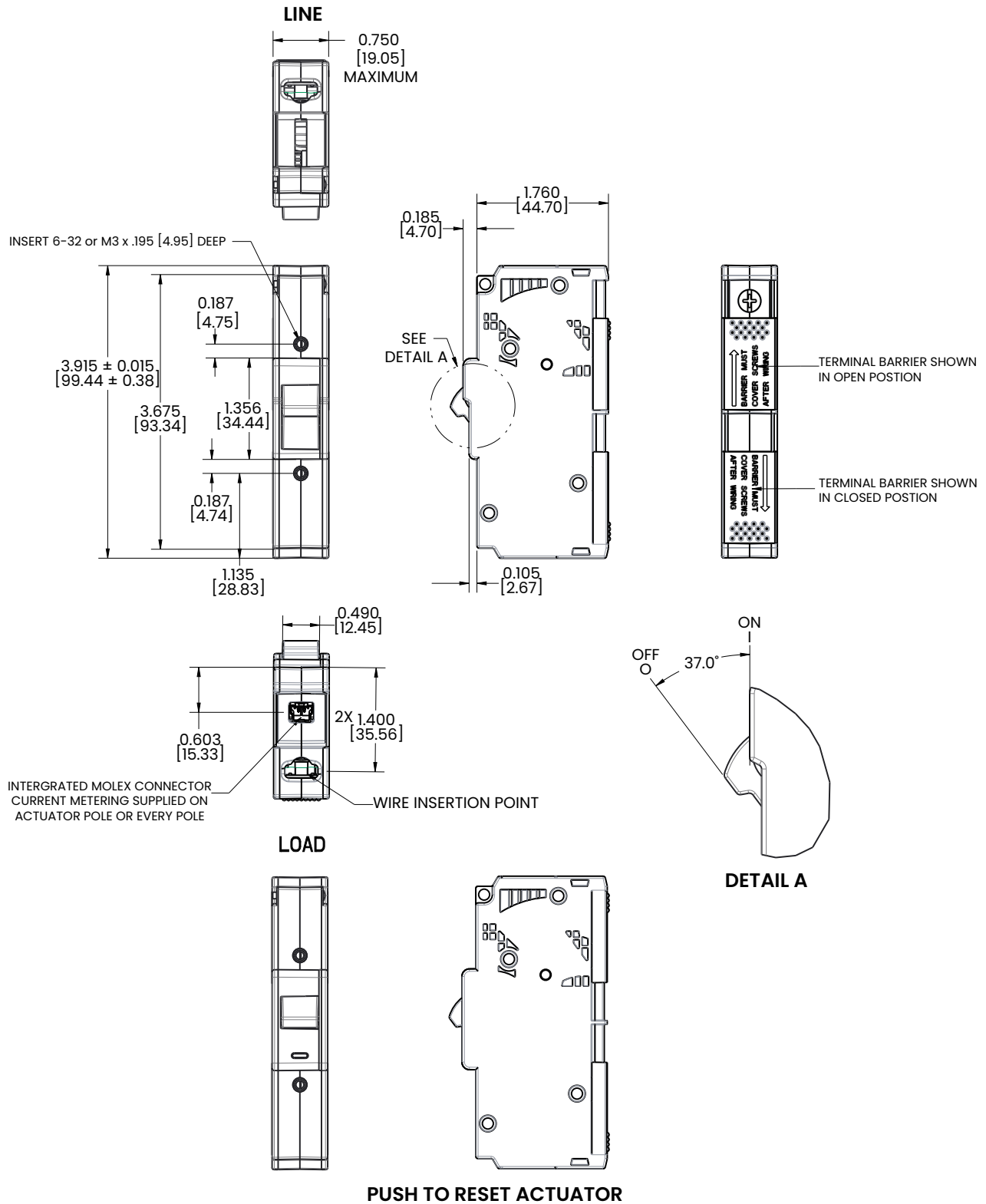

Notes:

1 Tolerance ±0.020 [.51] unless otherwise specified.

Dimensional Specs

inches [millimeters]

Figure 2. N-Series 2-Pole Construction

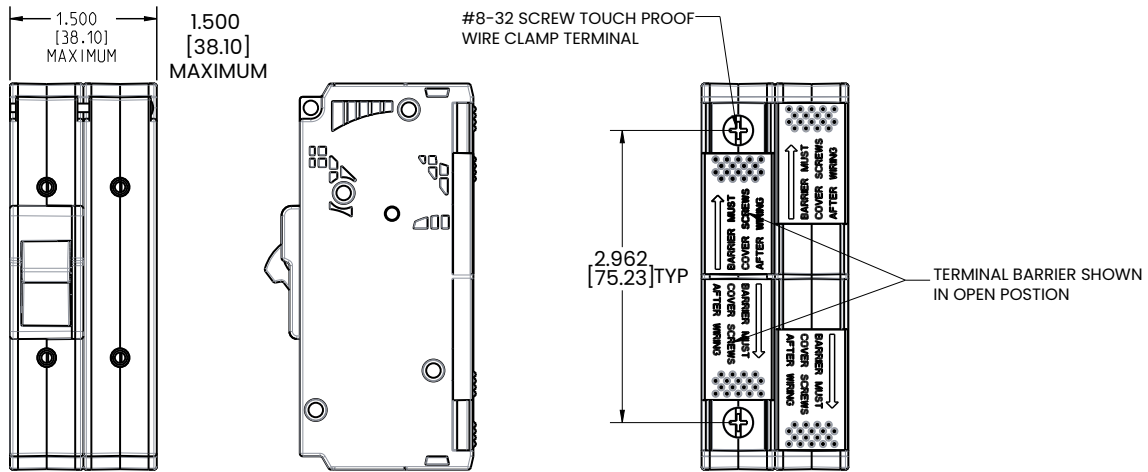

N-Series 3-Pole Construction

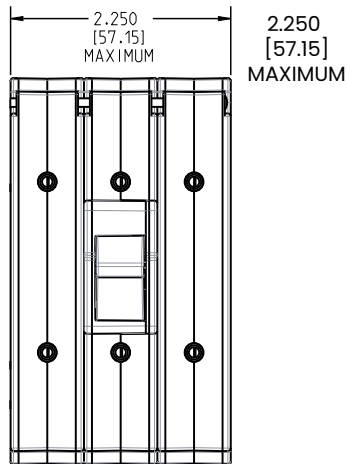
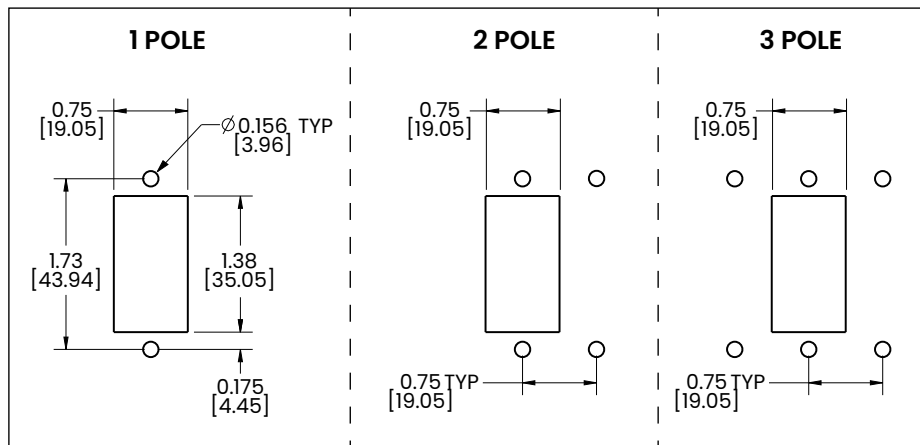

Figure 3. Panel Cutout Details



Notes:

1 Tolerance ± 0.020 [5] unless otherwise specified.

R-Series

Hydraulic Magnetic Circuit Breaker

PRODUCT WEBPAGE

request sample, configure part, watch video

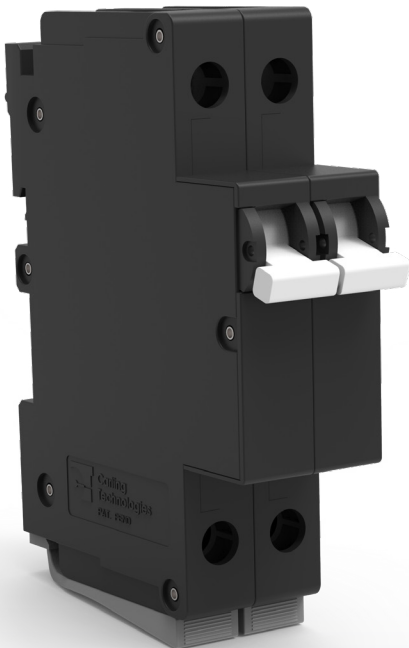
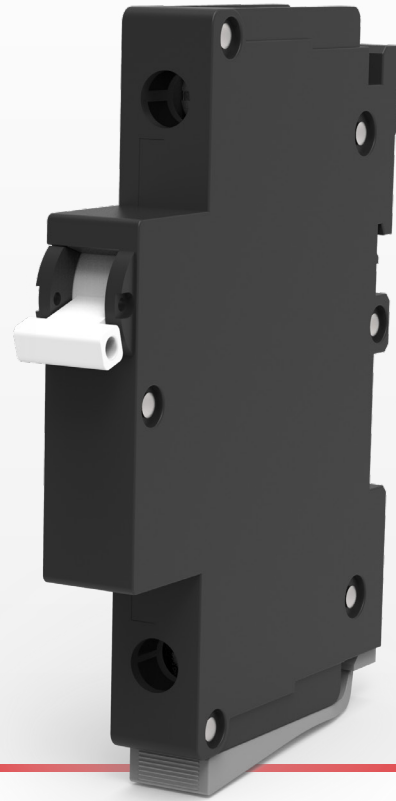

13mm DIN Rail Mounted Circuit Breaker

The R-Series hydraulic-magnetic circuit breaker combines maximum protection with ease of use. With no hardware or front panel cutout requirements, DIN rail mounting is a breeze with an optional rail button and choice of 45 or 57 mm mounting panels. In addition, the narrow width of the R-Series saves valuable real estate while providing additional space for revenue-generating devices. Finally, recessed wire-ready terminals are touch-proof and shock-resistant, ensuring safety.

1-4
Poles

1-200
Amps

80
VDC Max

480
VAC Max

Typical Applications

- Datacom/Telecom
- Renewable Energy
- Industrial Automation
- Railway

Tech Specs

Electrical

Maximum Voltage	AC: 240VAC (1-4 poles), 1 phase. 415VAC (2-4 poles), 3 phase. 480VAC (3 poles), 3 phase DC: 80VDC (1-4 poles)
Current Rating	1-63A 1-4 poles, 70-100A 2 poles parallel, 110-150A 3 poles parallel, 160-200A 4 poles parallel
Dielectric Strength	1500 VAC, 50/60Hz for 1 minute between all electrically isolated terminals of main circuit and between terminals of main circuit and auxiliary circuit.
Insulation Resistance	Minimum of 100 Megohms@500VDC
Resistance, Impedance	Values from Line to Load Terminal, based on Series Trip Circuit Breaker.

RESISTANCE, IMPEDANCE VALUES from Line to Load Terminals (Values Based on Series Trip Circuit Breaker)

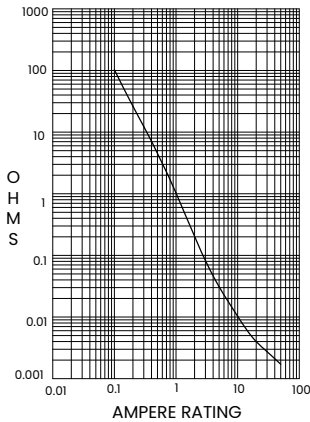

Endurance	10000 cycles, UL489A (1000 ON-OFF operations @ 6 per minute at rated voltage and current and 9000 mechanical operations), TUV and CCC (1500 ON-OFF operations @ 6 per minute at rated voltage and current and 8500 mechanical operations).
-----------	--

Mechanical

Trip Free	All R-Series circuit breakers will trip on overload, even when actuator is forcibly held in the ON position.
Trip Indication	The operating actuator moves positively to the middle position when an overload causes the breaker to trip. The breaker needs to be placed in the OFF position and can then be reset.

Physical

Number of Poles	1-4 poles
Termination	Cage terminal stranded conductor: Small Cage Terminal 1-4 pole series Max 63A, Wire size 25mm ² [4 AWG], torque: 2.26Nm [20 In-lbs] Medium Cage Terminal 2 pole parallel Max 100A, Wire size 55mm ² [1/0 AWG], torque: 6Nm [53.1 In-lbs] Large Cage Terminal 3 & 4 pole parallel Max 200A, Wire size 85mm ² [3/0 AWG], torque: 15Nm [132.76 In-lbs]
Mounting	DIN Rail. DIN lock is located at bottom of circuit breaker (load terminal side) when mounted vertically.
Weight	108g per pole
Width	13mm maximum per pole.

Environmental

Designed in accordance with requirements of specification MIL-PRF-55629 & MIL-STD-202 as follows:

Shock	Withstands 100 Gs, 6ms sawtooth while carrying rated current per Method 213, Test Condition "I". Instantaneous and ultrashort curves tested @ 90% of rated current
Vibration	Standard IEC60068-2-6 (2G sinusoidal wave). Table C.1, 10Hz to 150Hz, 20m/s ² , 20 sweep cycles in each axis. Ultrashort curves tested @ 90% of rated current.
Moisture Resistance	Method 106D, i.e., Ten 24-hour cycles @ +25°C to +65°C, 80-98% RH.
Salt Spray	Method 101, Condition A (90-95% RH @ 5% NaCl Solution, 96 hrs)
Thermal Shock	Method 107D, Condition A (five cycles @ -55°C to +25°C to +85°C to +25°C)
Operating Temperature	-40°C to +85°C.

Approvals

UL 489A, UL 1077, CSA 22.2 No. 235, TUV IEC/EN 60947-2, CCC GB14048.2

Tech Specs

Table A: Component Supplementary Protectors

Electrical Ratings										
Circuit Configuration	Voltage				Current (Amps)	Short Circuit Capacity (Amps) Without Backup Fuse				Application Codes
	Max Rating	Frequency	Phase	Poles	Full Load	UL 489A	UL 1077 / CSA	TUV / CCC		UL 1077 / CSA
								Icu	Ics	
Series	80 ¹	DC	—	1 - 4	1 - 63	10,000	—	10,000	5,000	—
	240	50/60	1		1 - 30	—	3,000	3,000	3,000	TC1, OL0, U3
	415		3	2 - 4	1 - 50		—			
	480			3	1 - 30		3,000	—	—	
	80 ^{1,2}	DC	—	2	70 - 100	10,000	—	10,000	5,000	—
				3	110 - 150					
				4	160 - 200					

Notes:

1. Polarity Sensitive
2. Parallel Pole Construction

Ordering Scheme Handle

Sample Part Number **R S 1 - B 1 - 24-620 - 1 1 - D E**

Selection 1 2 3 4 5 6 7 8 9 10 11

1. SERIES ¹

R R-Series Circuit Breaker

2. MOUNTING PANEL

S 45mm Mounting Panel
T 57mm Mounting Panel

3. POLES

1 One
2 Two
3 Three
4 Four

4. CIRCUIT

B Series Trip (Current)

5. RAIL BUTTON ²

1 With Rail Button
2 Without Rail Button

6. FREQUENCY & DELAY

11 DC Ultra Short
12 DC Short
14 DC Medium
16 DC Long
21 50/60 Hz Ultra Short
22 50/60 Hz Short
24 50/60 Hz Medium
26 50/60 Hz Long

7. CURRENT RATING (AMPERES)

CODE	AMPERES			
410	1.00	460 6.00	618 18.00	640 40.00
420	2.00	470 7.00	620 20.00	645 45.00
425	2.50	480 8.00	622 22.00	650 50.00
430	3.00	490 9.00	624 24.00	655 55.00
435	3.50	610 10.00	625 25.00	660 60.00
440	4.00	612 12.00	630 30.00	663 63.00
445	4.50	615 15.00	632 32.00	
450	5.00	616 16.00	635 35.00	

8. TERMINAL

1 Screw Terminal

9. ACTUATOR COLOR ³

1 White

10. MAXIMUM APPLICATION RATING

D 240V AC
J 415V AC
H 480V AC
M 80V DC

11. AGENCY APPROVALS ⁴

A Without Approvals
C UL Recognized, CSA Accepted
E TUV Certified, UL Recognized, CSA Accepted, CCC
U TUV Certified, CCC
T UL 489A Listed, CCC
7 UL 489A Listed, TUV Certified, CCC

Notes:

- Mid-Trip Handle type breaker, one per pole. Handle moves to mid-position only upon electrical trip of the breaker. When the handle is in the middle position, need to move handle to the "OFF" position, then the handle can be moved to the "ON" position.
- Rail button locations are only on the most left and right of the product for multi-pole breakers.
- ON/O-I/OFF markings are indicated on half shell, no marking will be on handle.
- Agency code C is only available with 240V AC 30 Amps max, 480V AC 30 Amps max. Agency code E is only available with 240V AC 30 Amps max. Agency code U is available with 240V AC, 415V AC 50 Amps max, 80V DC (Polarity Sensitive) 63 Amps max. Agency codes T and 7 are only available with 80VDC 63 Amps max. Polarity Sensitive.

 [Configure Complete Part Number >](#)

Ordering Scheme

Handle - Parallel Pole

Sample Part Number **R S 2 - P 1 - D4 - 670 - 1 1 - M T**

Selection 1 2 3 4 5 6 7 8 9 10 11

1. SERIES ¹

R R-Series Circuit Breaker

2. MOUNTING PANEL

S 45mm Mounting Panel
T 57mm Mounting Panel

3. POLES

2 Two
3 Three
4 Four

4. CIRCUIT ²

P Series Trip (Parallel Pole)

5. RAIL BUTTON ³

1 With Rail Button
2 Without Rail Button

6. FREQUENCY & DELAY

D1 DC Ultra Short
D2 DC Short
D4 DC Medium
D6 DC Long

7. CURRENT RATING (AMPERES) ⁴

CODE	AMPERES						
670	70.00	811	110.00	814	140.00	818	180.00
680	80.00	812	120.00	815	150.00	819	190.00
690	90.00	912	125.00	816	160.00	820	200.00
810	100.00	813	130.00	817	170.00		

8. TERMINAL

1 Screw Terminal M5
2 Screw Terminal with Busbar & Cage Terminal

9. ACTUATOR COLOR ⁵

1 White

10. MAXIMUM APPLICATION RATING ⁶

M 80V DC

11. AGENCY APPROVALS

A Without Approvals
T UL 489A Listed, CCC
7 UL 489A Listed, TUV Certified, CCC

Notes:

- Mid-Trip Handle type breaker, one per pole. Handle moves to mid-position only upon electrical trip of the breaker. When the handle is in the middle position, need to move handle to the "OFF" position, then the handle can be moved to the "ON" position.
- Line and Load terminals must be connected to a copper busbar having a minimum cross section of 0.078 square inches
- Rail button locations are only on the most left and right of the product for multi-pole breakers.
- Rated current code of 670-820 is only circuit "P"
Rated current 70-100 Amps must be two poles in parallel.
Rated current 110-150 Amps must be three poles in parallel.
Rated current 160-200 Amps must be four poles in parallel.
Contact Factory for special current levels.
- ON/O-I/OFF markings are indicated on half shell, no marking will be on handle
- Polarity Sensitive

 [Configure Complete Part Number >](#)

Dimensional Specs

inches [millimeters]

1 POLE WITHOUT RAIL BUTTON

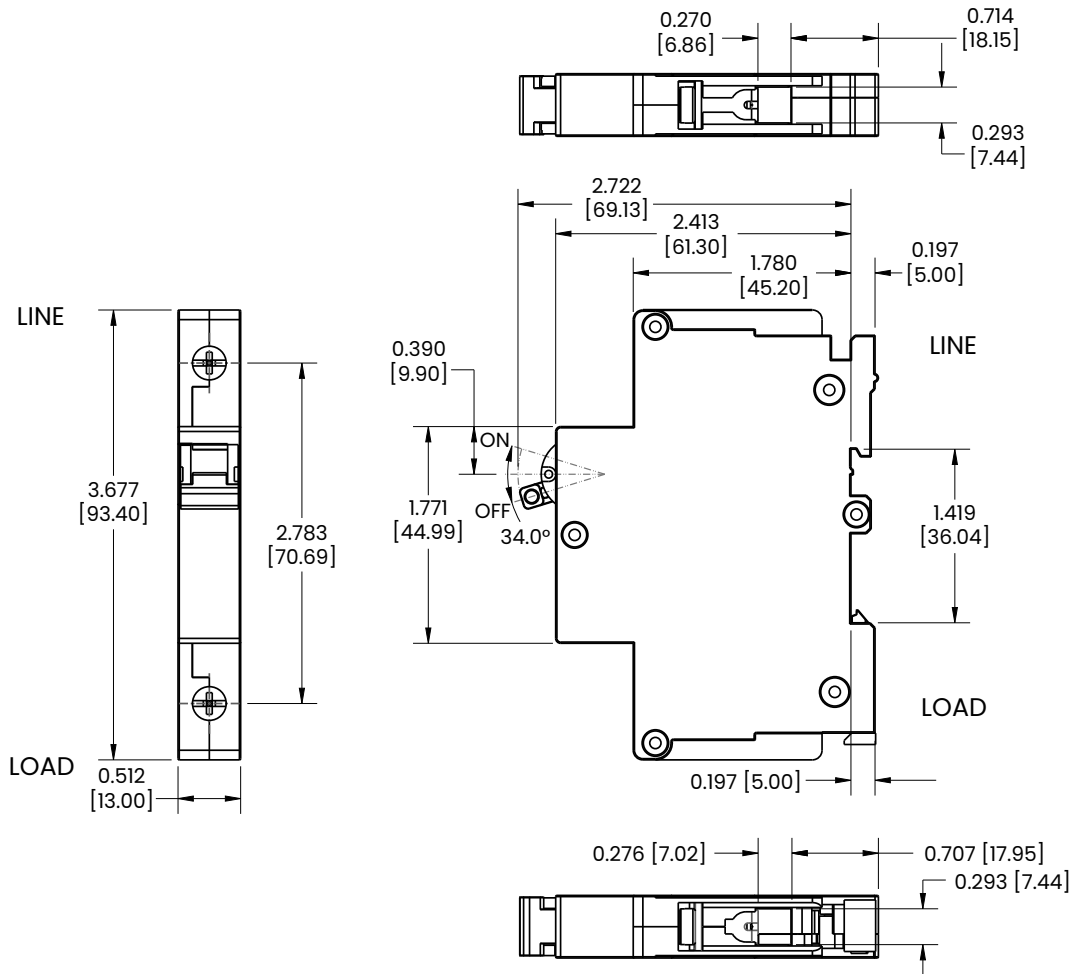

1 POLE WTH RAIL WAY LOCK OPEN BUTTON

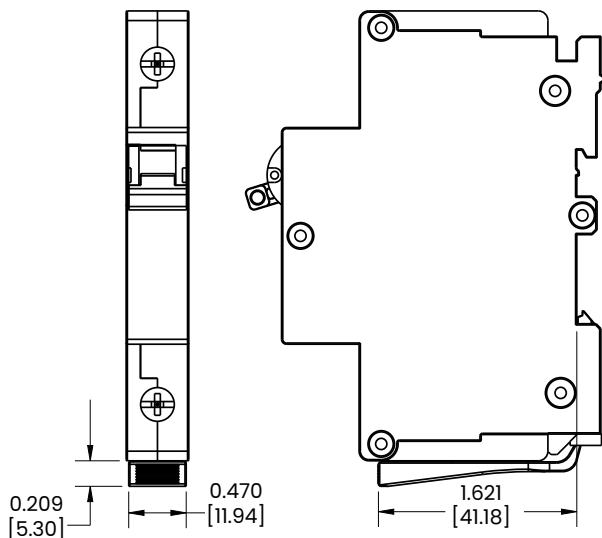

OPTIONAL 57MM MOUNTING PANEL

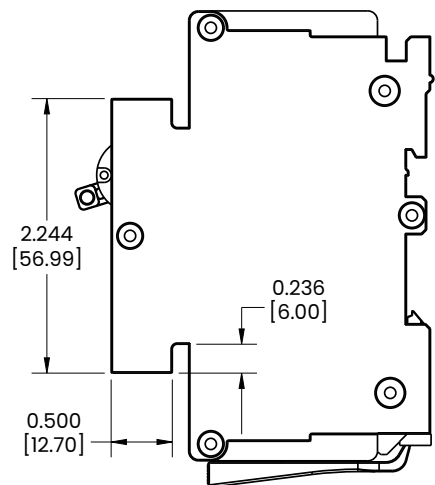

Notes:

- 1 Tolerance $\pm .010$ [0.25] unless otherwise specified
- 2 Angles $\pm 1^\circ$

CLA-8143 Rev B

*Manufacturer reserves the right to change product specification without prior notice.

Dimensional Specs

inches [millimeters]

MULTIPLE POLES WITH RAIL WAY LOCK OPEN BUTTON AND BUS BAR

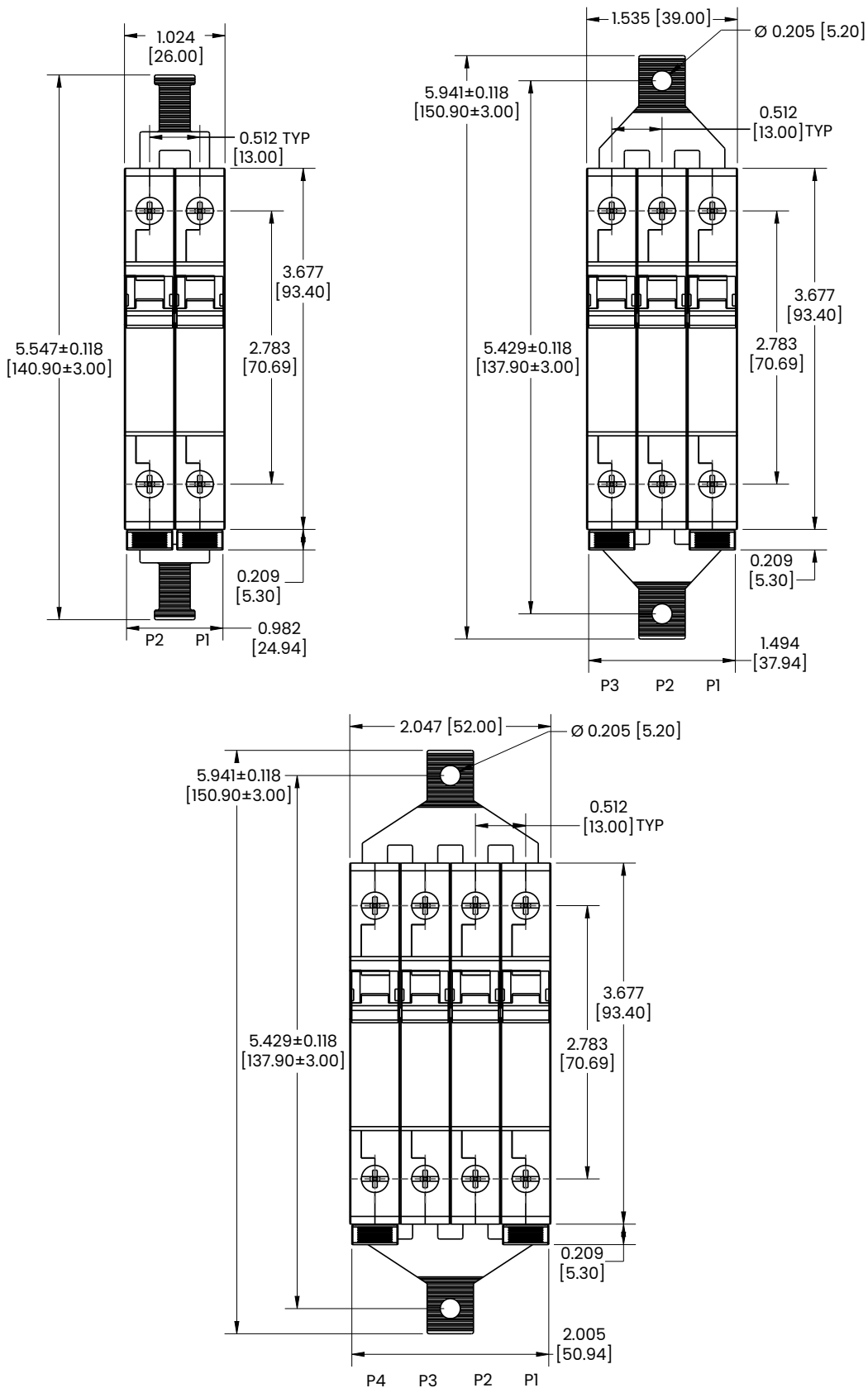

Notes:

- 1 Tolerance ± .010 [0.25] unless otherwise specified
- 2 Angles ± 1°

CLA-8143 Rev B

*Manufacturer reserves the right to change product specification without prior notice.

Dimensional Specs

inches [millimeters]

2 POLE CAGE TERMINAL MOUNTING

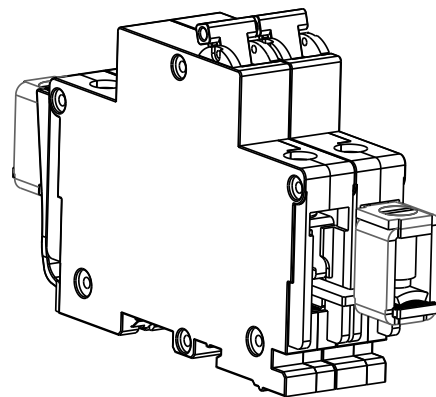
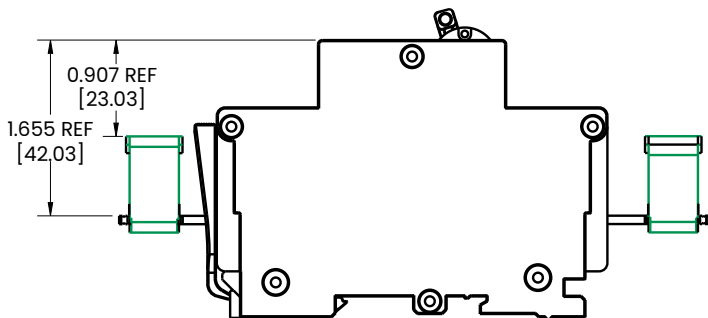
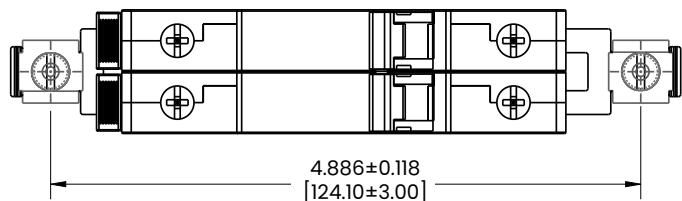

3 AND 4 POLE CAGE TERMINAL MOUNTING

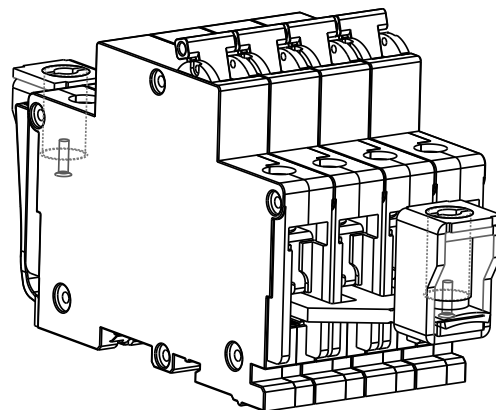
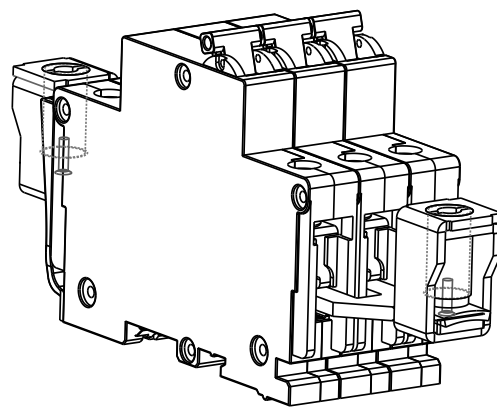
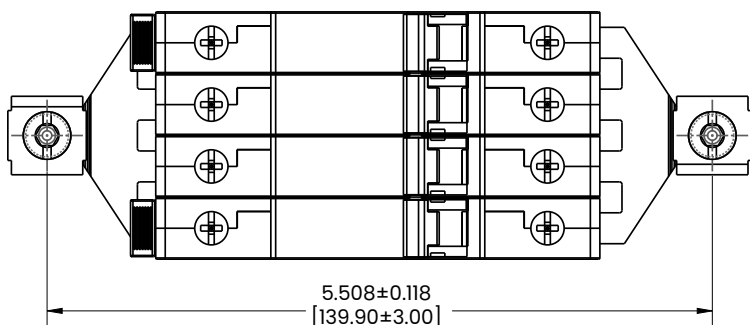
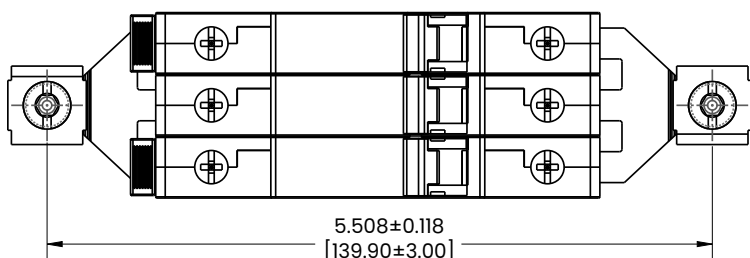

CAGE TERMINAL FOR PARALLEL POLES

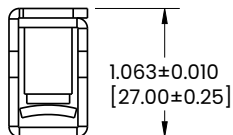
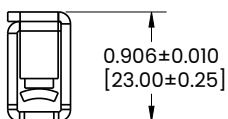
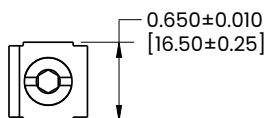
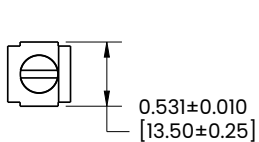

RCT-01
FOR 2 POLE BUSBAR

RCT-02
FOR 3 OR 4 POLE BUSBAR

CAGE TERMINAL

TABLE A
TIGHTENING TORQUE SPECIFICATION

APPLICATION	CAGE TERMINAL	WIRE RANGE AWG	TOQUE IN-LBS (Nm)
1-4 POLE SERIES	SMALL	4 AWG	20 (2.26)
2 POLE PARALLEL	MEDIUM	1/0 AWG	53.1 (6)
3&4 POLE PARALLEL	LARGE	3/0 AWG	132.76 (15)

Accessories Ordering Schemes

Panel Hole Plug

Threaded insert A & B-Series hole plugs are available in gloss finish. Snap-In A & B-Series hole plugs are available in matte finish.

Sample Part Number 8 M 1 - C - 1 2

Selection 1 2 3 4 6 7



1. ACCESSORY CODE

8

2. SERIES

A A & B-Series
C C & D-Series
M M-Series

3. POLES

1 One Pole
A, B, C & D-Series Front Panel Snap-In Only
2 Multi-Pole Inner
3 Multi-Pole Outer

4. ACCESSORY TYPE

C Panel Hole Plug

5. ACTUATOR TYPE & MOUNTING STYLE

	Actuator Type	Mounting Style
1	M-Series Rocker	Front Panel Snap-In
2	A & B-Series Rocker	6-32 Threaded Insert
3	A & B-Series Rocker	ISO M3 Threaded Insert
6	C & D-Series Handle	6-32 Threaded Insert
7	C & D-Series Handle	ISO M3 Threaded Insert
8	A, B, C & D-Series Handle	Front Panel Snap-In

6. COLOR

1 White (M-Series only)
2 Black
7 Gray (M-Series only)

7. FINISH

1 Matte
2 Gloss (A & B-Series only)

A & B-Series PCB Socket

The PCB socket is available with the A-Series Handle, DC up to 30 amps; A-Series Rocker, AC/DC up to 30 amps, and B-Series handle, AC/DC up to 30 amps.

Sample Part Number 8 A 1 - 1 2 1

Selection 1 2 3 4 5 6



1.ACCESSORY CODE

8

2. SERIES

A A & B-Series

3. POLES

1 One Pole

4. INTERFACE WITH AUXILIARY SWITCH

1 Yes
2 No

5. AUXILIARY SWITCH TERMINAL TYPE

1 TAB, 0.110 Inches (Symmetrical terminal spacings)
3 None

6. COLOR

B Black

Accessories Ordering Schemes

C-Series with Push-In Stud Terminals Removal Tool

Sample Part Number **8C1-X0-08-639**

Selection 1

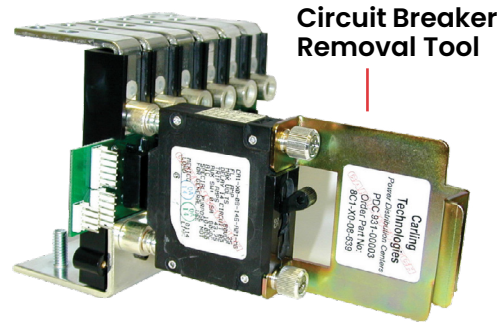

1. PART NUMBER

8C1-X0-08-639 Removal Tool for 6-32 inserts
8C1-X0-09-593 Removal Tool for M3 inserts

C & E-Series Power Selector

The number of lockout sliding handles provided is one less than the number of sections specified, allowing one section to be live at a time.

Sample Part Number **8 E 6 - B - C 3 1**

Selection 1 2 3 4 5 6 7

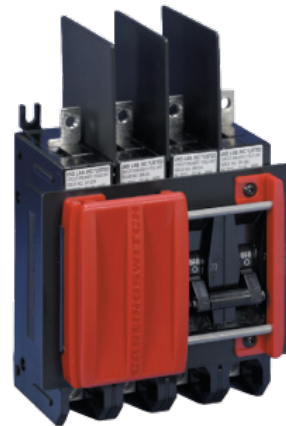

1. ACCESSORY CODE

8

2. SERIES

C C & D-Series
E E-Series

3. POLES

4 4 Poles
6 6 Poles
9 9 Poles (only available on E-Series)

4. ACCESSORY TYPE

B Power Lockout Kit

5. SECTIONS & POLES PER SECTION

	Number of Sections	Poles Per Section
B	Two	Two
C	Two	Three
F	Three	Two
G	Three	Three

6. COLOR

1 TAB, 0.110 Inches (Symmetrical terminal spacings)
3 None

7. STYLE

1 Carling Logo

Time Delay M, MS, K-Series

M, MS, K-SERIES TIME DELAY VALUES											
TRIP TIME SECONDS	PERCENT OF RATED CURRENT										
	Delay	100%	135%	150%	200%	400%	600%	800%	1000%	1200%	
	10, 20, 30	No Trip	May Trip	.100 Max	.100 Max	.100 Max	.100 Max	.100 Max	.100 Max	.100 Max	.100 Max
	12, 22, 32, 62, 72, 92		.300 - 7.00	.100 - 5.00	.100 - 2.00	.030 - .500	.008 - .300	.006-.150	.005 - .100	.005 - .100	
14, 24, 34, 64, 74, 94	3.00 - 70.0		2.00 - 40.0	1.00 - 15.0	.100 - 4.00	.008 - 2.00	.006-.800	.005 - .350	.005 - .160		

Notes:

- 1 Delay Curves 12,14, 22, 24, 32, 34, 62, 64, 72, 74, 92, 94: Breakers to hold 100% and must trip at 135% of rated current and greater within the time limit shown in this curve.
- 2 Delay Curves 10, 20, 30: Breakers to hold 100% and must trip at 150% of rated current and greater within the time limit shown in this curve.
- 3 All Curves: Curve data shown represents breaker response at ambient temperature of 77°F (25°C) with no preloading. Breakers are mounted in standard wall-mount position.
- 4 The minimum inrush pulse tolerance handling capability is 12 times the rated current on standard delays and 18 times the rated current on high inrush delays. These values are based on a 60 Hz 1/2 cycle, 8.33 ms pulse. High inrush delays should be specified for applications with high initial surge currents of short duration, such as switching power supplies, highly capacitive loads and transformer loads.

Dual Rated AC/DC

Instantaneous

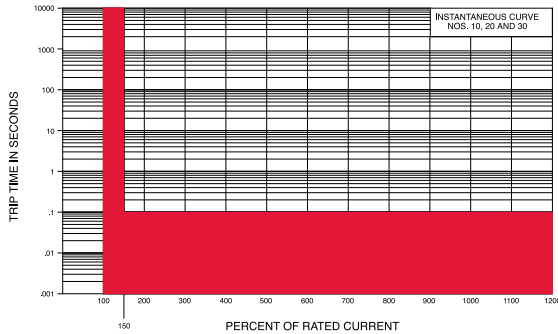

Short

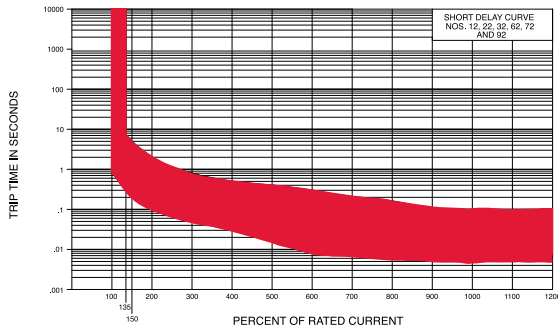

Short D2

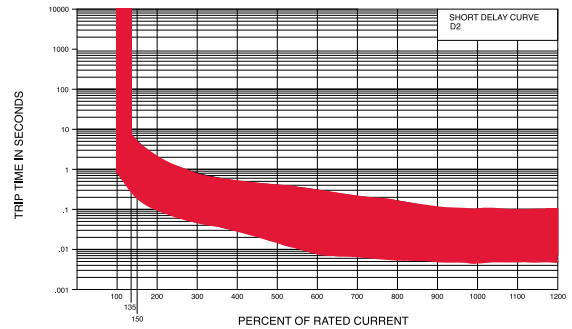

Medium

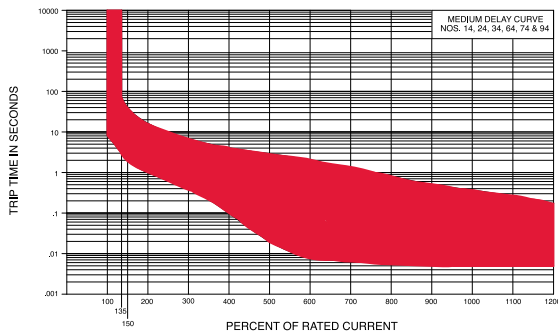

Medium D4

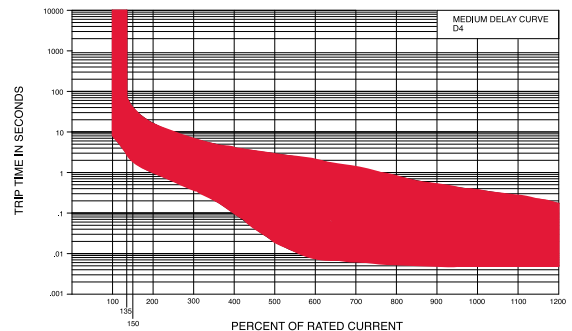

Time Delay

A, B, TB, C, CX, D, G, H, J, L, N & R-Series

		A, B, TB, C, CX, D, G, H, J, L, N & R-SERIES TIME VALUES									
		PERCENT OF RATED CURRENT									
TRIP TIME (SECONDS)	Delay	100%	125%	135%	150%	200%	400%	600%	800%	1000%	1200%
	10		No Trip	May Trip	-	.032 Max	.024 Max	.020 Max	.018 Max	.016 Max	.015 Max
11	.013 - .125	.010 - .070		.008 - .032		.006 - .020	.005 - .020	.004 - .020	.004 - .020	.004 - .020	.004 - .020
12	.500 - 6.50	.300 - 3.00		.130 - 1.20		.031 - .220	.011 - .120	.004 - .090	.004 - .060	.004 - .040	
14	2.00 - 60.0	1.20 - 40.0		600 - 20.0		.150 - 3.00	.030 - 1.30	.004 - .600	.004 - .100	.004 - .100	
16	45.0 - 345	20.0 - 150		9.00 - 60.0		1.40 - 11.4	.150 - 5.80	.009 - 3.70	.005 - 1.70	.005 - .500	
20	May Trip	.040 Max		.035 Max		.030 Max	.025 Max	.020 Max	.017 Max	.015 Max	
21	.014 - .150	.011 - .095		.008 - .055		.006 - .035	.005 - .027	.005 - .021	.004 - .018	.004 - .017	
22	.700 - 12.0	.350 - 4.00		.130 - 1.30		.027 - .220	.008 - .130	.004 - .090	.004 - .045	.004 - .040	
24	10.0 - 160	6.00 - 60.0		2.20 - 20.0		.300 - 3.00	.050 - 1.30	.007 - .500	.005 - .060	.005 - .040	
26	50.0 - 700	32.0 - 350		10.0 - 90.0		1.50 - 15.0	.500 - 7.00	.020 - 3.00	.006 - 2.00	.005 - 1.00	
32	May Trip	.400 - 8.00		.300 - 4.00		.130 - 1.30	.027 - .220	.008 - .130	.004 - .090	.004 - .060	.004 - .040
34	May Trip	1.80 - 100		1.20 - 60.0		600 - 20.0	.150 - 3.00	.030 - 1.30	.004 - .600	.004 - .110	.004 - .100
36	May Trip	35.0 - 520		20.0 - 350		9.00 - 90.0	1.40 - 15.0	.150 - 7.00	.009 - 3.70	.005 - 2.0	.004 - 1.00
42	.700 - 12.0	.400 - 6.00		180 - 2.30		.050 - .600	.026 - .300	.018 - .200	.014 - .150	.012 - .130	
44	7.00 - 100	3.00 - 50.0		1.10 - 18.0		.220 - 3.00	.120 - 1.70	.075 - 1.20	.050 - .850	.042 - .720	
46	50.0 - 700	31.0 - .350		12.0 - 150		1.50 - 20.0	.700 - 10.0	.404 - 7.90	.260 - 6.50	.198 - 5.80	
52	.500 - 6.50	.340 - 4.50		.180 - 2.30		.051 - .600	.030 - .320	.018 - .220	.014 - .200	.012 - .130	
54	1.50 - 50.0	.750 - 35.0		.350 - 18.0		.110 - 3.00	.070 - 1.70	.045 - 1.40	.039 - 1.30	.035 - 1.30	
56	45.0 - 345	19.0 - 170		8.50 - 100		1.24 - 15.0	.410 - 9.00	.256 - 8.00	.210 - 5.50	.198 - 2.90	

Notes:

UL489 C-Series Breakers available with Delay Curves 11, 12, 14, 16, 21, 22, 24, 26, 42, 44, 46.
 Delay Curves 11,12,14,16,21,22,24,26,42,44,46,52,54,56: Breakers to hold 100% and must trip at 125% of rated current and greater within the time limit shown in this curve.
 Delay Curves 32,34,36: Breakers to hold 100% and must trip at 135% of rated current and greater within the time limit shown in this curve.
 Delay Curves 10,20: Breakers to hold 100% and must trip at 150% of rated current and greater within the time limit shown in this curve.
 All Curves: Curve data shown represents breaker response at ambient temperature of 77°F (25°C) with no preloading. Breakers are mounted in standard wall-mount position.
 On 50 amp and less current ratings, the minimum inrush pulse tolerance handling capability is 12 times the rated current on standard delays and 25 times the rated current on high inrush delays. These values are based on a 60 Hz 1/2 cycle, 8.33 ms pulse. High inrush delays should be specified for applications with high initial surge currents of short duration such as switching power supplies, highly capacitive loads and transformer loads.

Instantaneous

AC

DC

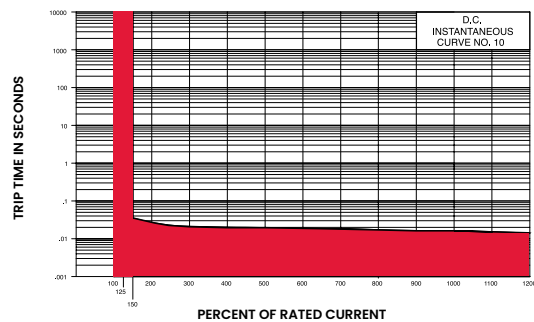
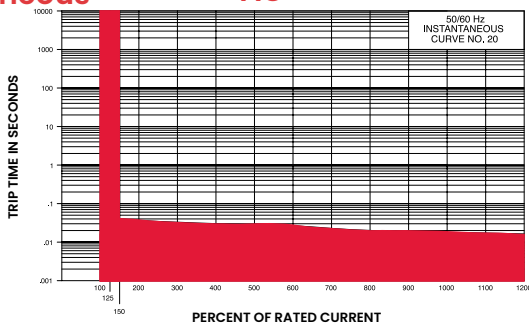

Ultrashort

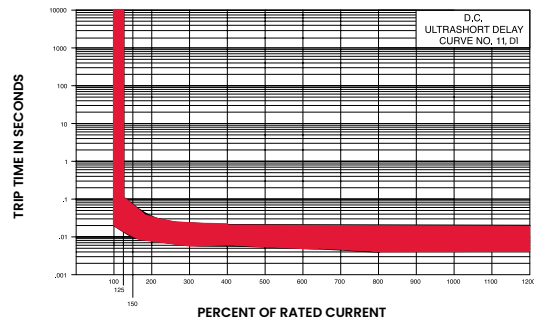
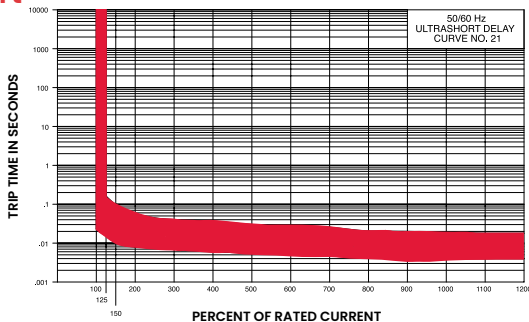

Short

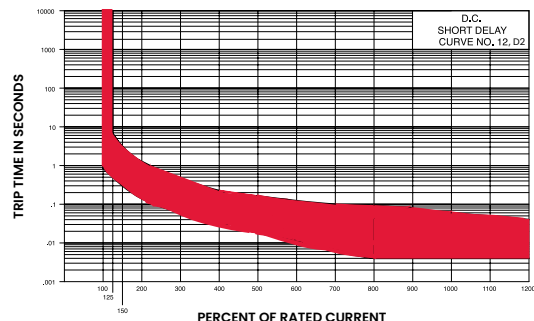
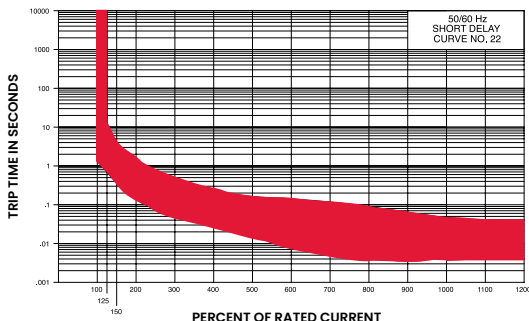

Time Delay

A, B, TB, C, CX, D, G, H, J, L, N & R-Series

Medium

AC

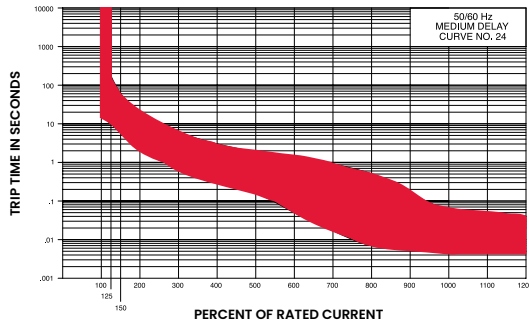

DC

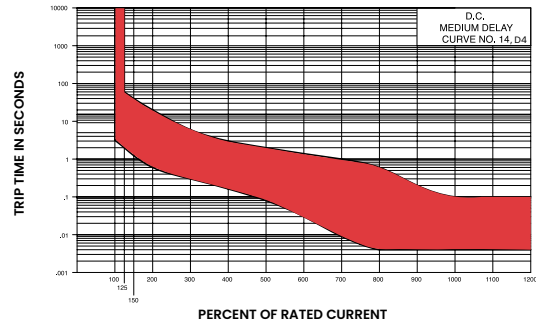

Long

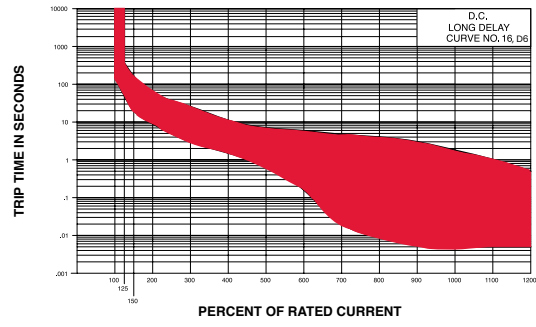
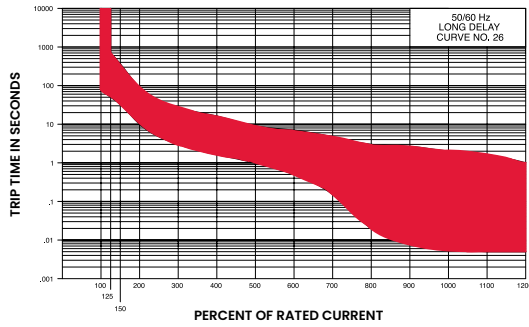

Short

High Inrush AC

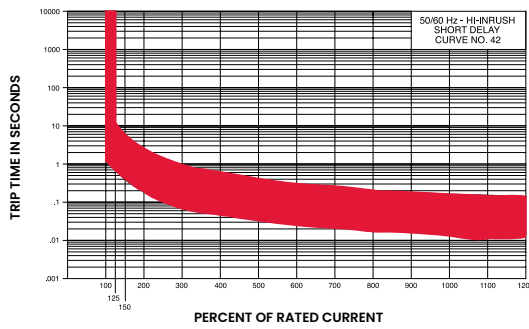

High Inrush DC

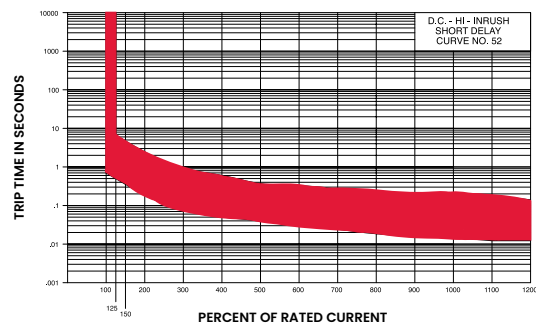

Medium

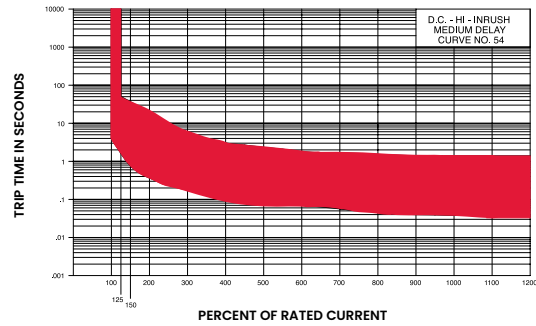
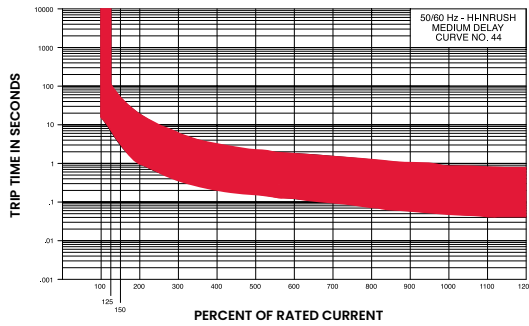

Long

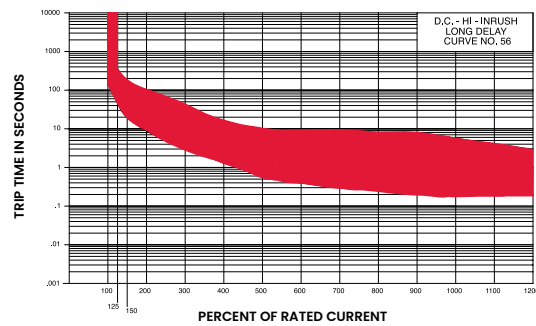
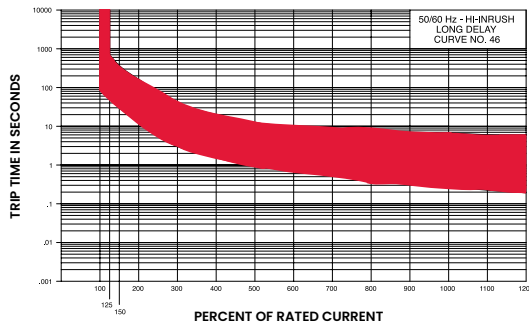

Time Delay

A, B, TB, C, CX, D, G, H, J, L, N & R-Series

AC/DC

Short

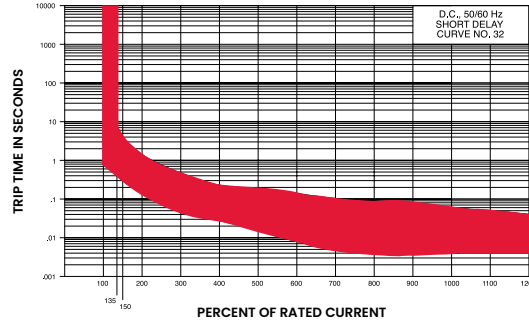

Medium

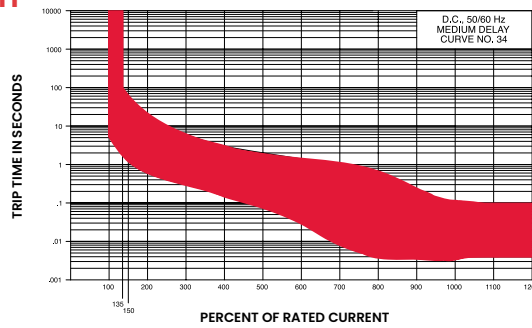

Long

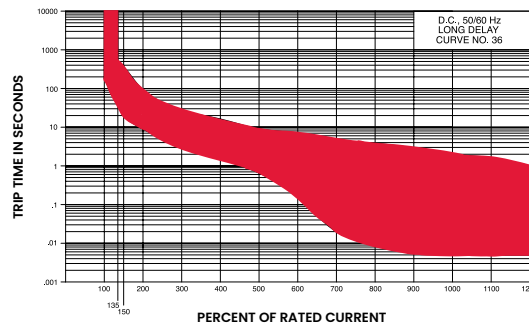

Time Delay E-Series

E-SERIES TIME DISPLAY VALUES												
TRIP TIME (SECONDS)	PERCENT OF RATED CURRENT											
	Delay	100%	125%	135%	150%	200%	400%	600%	800%	1000%	1200%	
10	No Trip	May Trip			.001 - .038	.001 - .032	.001 - .021	.001 - .019	.001 - .019	.001 - .019	.001 - .019	
12, 72		.600 - 7.00			.330 - 2.00	.150 - .800	.033 - .160	.016 - .071	.010 - .048	.008 - .040	.008 - .040	
14, 74		11.0 - 110			6.00 - 45.0	3.00 - 18.0	.280 - 3.50	.013 - 1.50	.010 - .130	.009 - .090	.009 - .080	
16, 76		100 - 800			50.0 - 360	20.0 - 120	3.00 - 25.0	.020 - 11.0	.010 - .700	.009 - .230	.009 - .200	
20		May Trip	-		.001 - .040	.001 - .031	.001 - .020	.001 - .020	.001 - .020	.001 - .020	.001 - .020	
22, 62		.800 - 5.00			.400 - 2.30	.150 - .900	.034 - .170	.020 - .080	.012 - .051	.010 - .040	.009 - .040	
24, 64		7.20 - 90.0			4.40 - 35.0	2.00 - 15.0	.500 - 3.50	.025 - 1.60	.012 - .330	.010 - .070	.009 - .050	
26, 66		50.0 - 500			32.0 - 250	14.0 - 120	2.50 - 24.0	.320 - 7.00	.0125 - 3.10	.011 - .130	.010 - .055	
30					.001 - .040	.001 - .032	.001 - .020	.001 - .020	.001 - .020	.001 - .020	.001 - .020	
32, 92		May Trip	.450 - 5.20			.330 - 2.30	.150 - .900	.033 - .170	.016 - .080	.009 - .051	.008 - .040	.008 - .040
34, 94			5.80 - 73.0			4.40 - 45.0	2.00 - 18.0	.280 - 3.60	.013 - 1.60	.010 - .330	.009 - .090	.009 - .080
36, 96			42.0 - 600			32.0 - 360	14.0 - 120	2.50 - 25.0	.020 - 11.0	.010 - 4.10	.009 - .330	.009 - .200

Notes

Delay Curves 10,20,30: Breakers to hold 100% and must trip at 150% of rated current and greater within the time limit shown in these curves.
 Delay Curves 12,14,16,22,24,26,62,64,66,72,74,76: Breakers to hold 100% and must trip at 125% of rated current and greater within the time limit shown in these curves.
 Delay Curves 32,34,36,92,94,96: Breakers to hold 100% and must trip at 135% of rated current and greater within the time limit shown in these curves.
 All curves: Data shown represents breaker response at ambient temperature of 77°F (25°C) with no preloading; Breakers are mounted in standard wall-mount position.
 The minimum inrush pulse tolerance handling capacity on the above standard delays is 16 times rated current & 20 times rated current for high inrush delays based on a 60Hz 1/2 cycle, 8.33 ms pulse.

Instantaneous

AC

DC

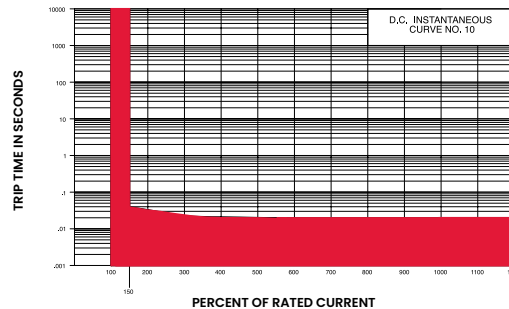
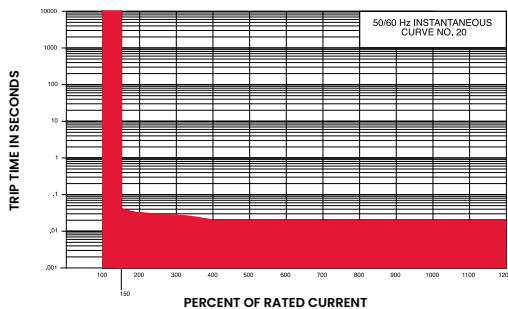

Short

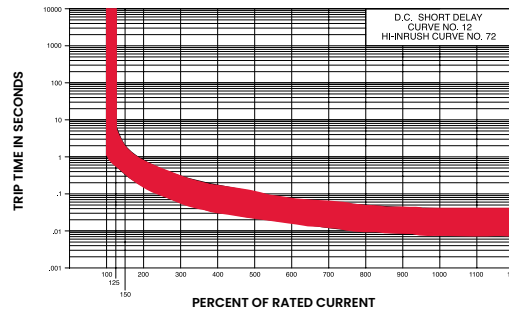
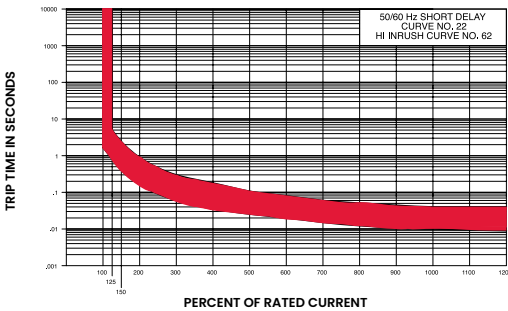

Medium

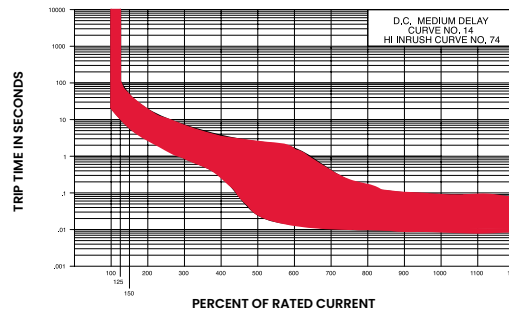
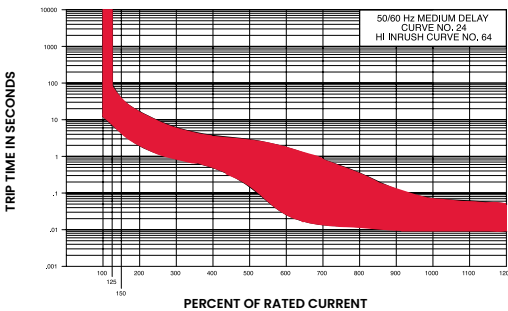

Long

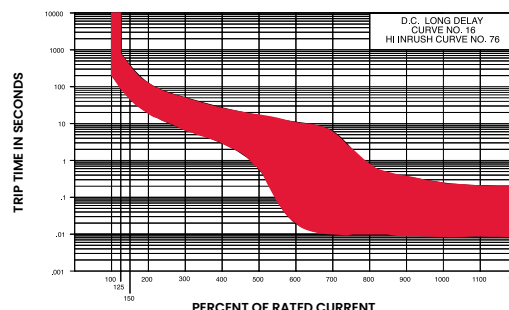
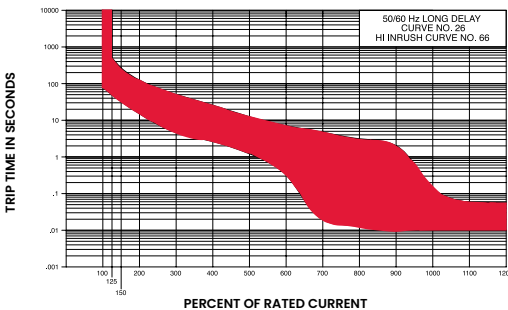

Time Delay E-Series

AC/DC

Instantaneous

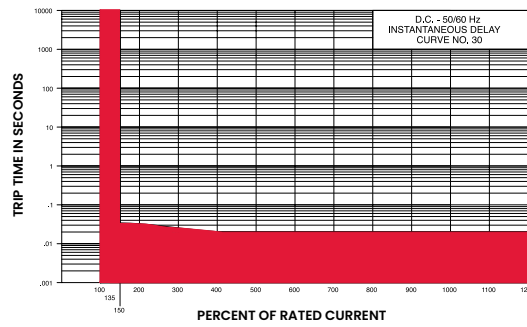

Short

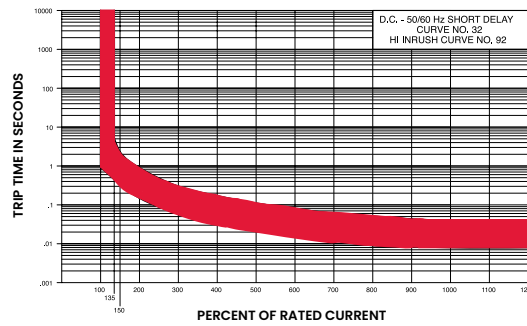

Medium

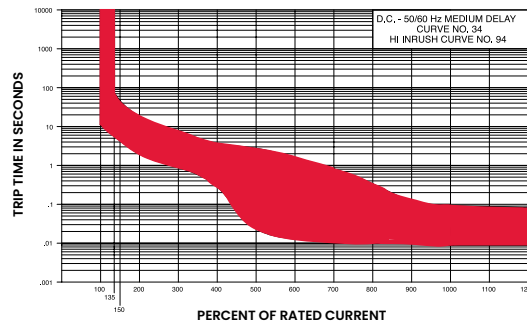

Long

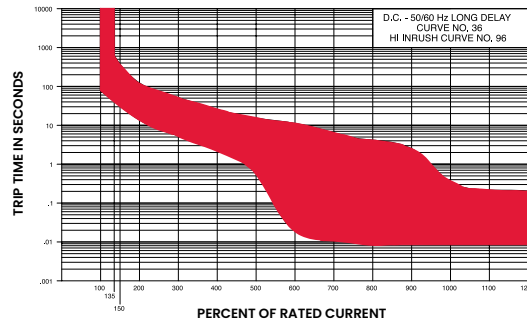

Time Delay F-Series

F-SERIES TIME DISPLAY VALUES									
TRIP TIME (SECONDS)	PERCENT OF RATED CURRENT								
	Delay	100%	125%	150%	200%	400%	600%	800%	1000%
11	No Trip	.013 - .125	.010 - .070	.008 - .032	.006 - .020	.005 - .020	.004 - .020	.004 - .020	.004 - .020
12		.475 - 10.0	.275 - 2.80	.140 - .850	.030 - .190	.015 - .125	.010 - .050	.008 - .038	.008 - .038
14		10.0 - 110	6.00 - 40.0	2.50 - 15.0	.500 - 3.00	.180 - 1.00	.010 - .280	.008 - .080	.008 - .080
16		110 - 1000	60.0 - 400	22.0 - 150	4.00 - 25.0	1.00 - 5.50	.010 - 1.80	.008 - .390	.008 - .390
22		0.44 - 10.0	0.25 - 2.80	0.13 - 0.90	0.030 - 0.19	0.015 - 0.125	0.010 - 0.055	0.008 - 0.045	0.008 - 0.045
24		7.20 - 110	4.40 - 45.0	2.00 - 18.0	0.25 - 3.50	0.016 - 1.60	0.009 - 0.33	0.008 - 0.11	0.008 - 0.11
26		100 - 1100	32.0 - 400	14.0 - 150	2.50 - 25.0	0.020 - 11.0	0.010 - 3.10	0.008 - 0.39	0.008 - 0.39

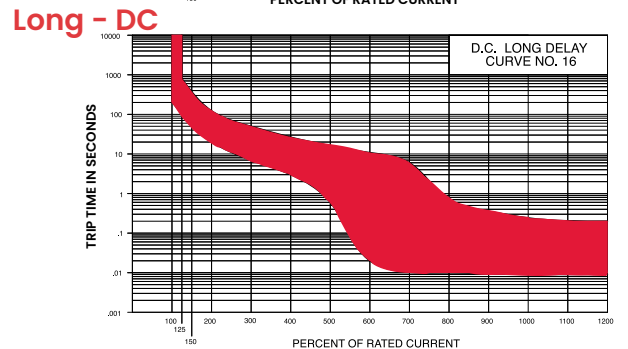
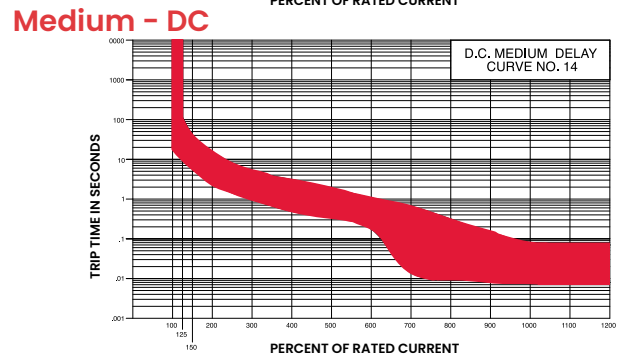
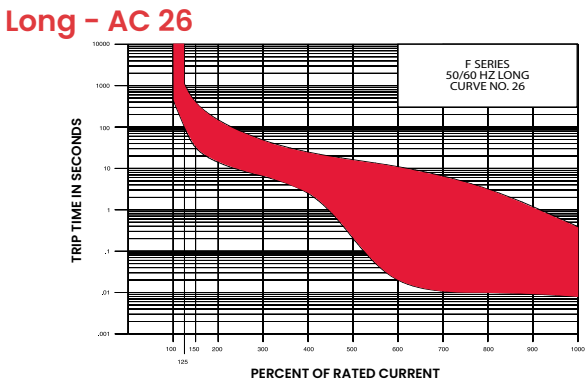
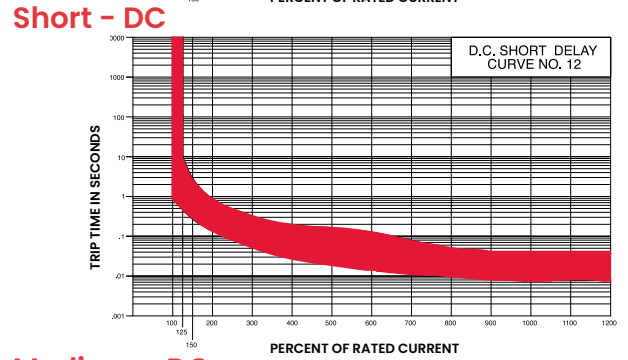
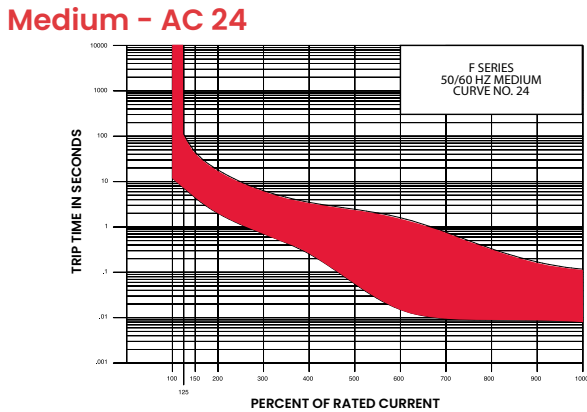
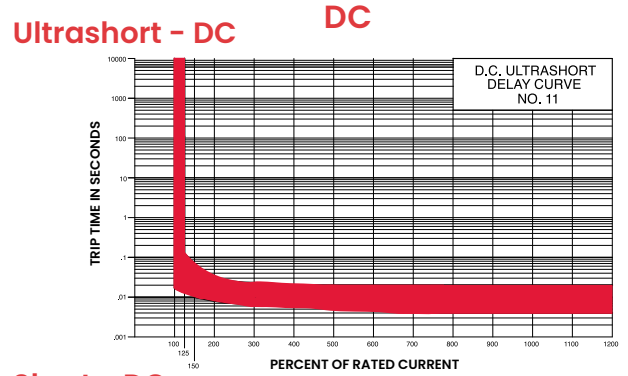
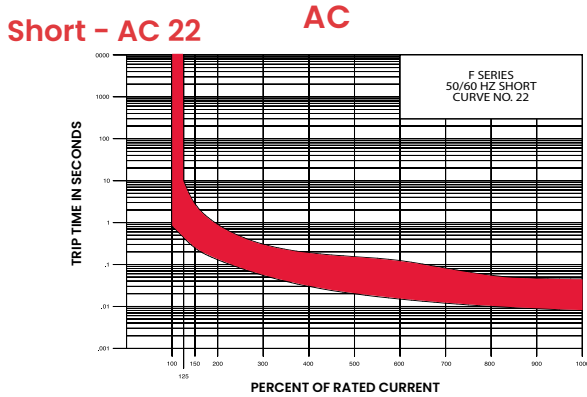

Technical Glossary

A

Alternating Current

A periodic current (sine wave) whose average value over a cycle is zero. The current reverses at regular intervals of time and has alternately positive and negative values.

Ambient Temperature

The temperature of the medium in which the heat of a device is dissipated. The ambient temperature is often specified in standards for device performance (such as the UL Standards) as the basis for determining the heat rise of the component.

Ampacity

The current carrying capacity of a conductor or device.

Ampere

see coulomb
1) The classic definition of an ampere is a unit of electric current flow equivalent to the motion of 1 coulomb of charge, or 6.28×10^{18} electrons, past any cross section in 1 second. This is an intuitive way to think about an ampere, it is the flow of a huge number of electrons through a conductor.

2) In 1948 this alternative definition was adopted: A unit of electric current in the meter-kilogram-second system. It is the steady current that when flowing in straight parallel wires of infinite length and negligible cross section, separated by a distance of one meter in free space, produces a force between the wires of 2×10^{-7} newtons per meter of length.

B

Battery

see cell
Two or more cells connected together. Thus a group of batteries connected together can also be referred to as a battery

Battery Bank

When groups of 6V or 12V batteries are wired in series or parallel or a combination to increase voltage or capacity the entire group is referred to as a battery bank. When batteries are connected in series the amp-hour rating is the same and the voltage is additive. When batteries are connected in parallel the voltage is the same and the amp-hour rating is additive.

Battery State-Of-Charge

The term is used to describe and estimate of how much energy the battery is able to deliver. There have been many attempts to develop improved state-of-charge estimates. The most common methods include specific gravity, at-rest open-circuit voltage, and amp-hour measurement.

Branch Circuit

see main
The portion of the wiring system after the main circuit protection device.

Break (rating)

The amount of current that can be passing through a set of contacts, such as those in a solenoid, when they open, without damaging the contacts. This can be a rating for a single event or over some number of cycles, generally 1000, 10,000 or 1000,000.

Bus, Busbar

A bus is a group of common connections, often consisting of a strip of copper or brass with a number of screws or bolt studs for the connection of wires. It may be a negative or a positive bus.

C

Cascade Circuit

A series arrangement of more than one protector connected between the power source and the load.

CE (Conformité Européen)

The CE marking is a conformity marking consisting of the letters "CE". The CE marking is applied to products regulated by certain European health, safety and environmental protection legislation. The CE marking is obligatory for products it applies to. The manufacturer affixes the marking certifying that the product conforms to applicable regulations, in order to be allowed to sell his product in the European market.

Cell

An electrochemical system that converts chemical energy into electrical energy. Typically consisting of two conductive plates with different galvanic potential immersed in an electrolyte.

Charge

Classically refers to an accumulation of electrons producing an electrostatic charge. In common use it often refers to restoring energy to a battery. Specifically, it would refer to the part of a multistage battery charging cycle when the voltage was held constant at or about the gassing voltage.

Circuit

A closed path of electrically, or electro-magnetically connected, components or devices that is capable of current flow. Typically consisting of loads, sources, conductors, and circuit protection (circuit breakers and fuses). For example: A battery, fuse, and bilge pump connected together with wire are a circuit. The path must be continuous and closed.

Circuit Breaker

A device that, like a fuse, interrupts a current in an electric circuit when the current becomes too high. Unlike a fuse, a circuit breaker can be reset after it has been tripped. When a high current passes through the circuit breaker, the heat it generates or the magnetic field it creates causes a trigger to rapidly separate the pair of contacts that normally conduct the current.

Circular Mils

A method of specifying wire size mathematically. One Circular Mil is a unit of area equal to that of a circle .001" in diameter.

The actual area of a Circular Mil is:

$A = \pi r^2$

$A = 3.1428 \times (.0005)^2$ inches

$A = .000007857$ square inches

Cold Cranking Amperes (CCA)

see marine cranking amperes
CCA is the discharge load in amps, which a battery can sustain for 30 seconds at 0° F. and not fall below 1.2 volts per cell (7.2V on 12V battery). This battery rating measures a burst of energy that an engine needs to start in a cold environment. This rating is used mainly for rating batteries for engine starting capacity and does not apply to NiCad batteries, NiMH batteries or Alkaline batteries.

Common Trip

A feature on a multi-pole protector in which an overload on any pole will cause all poles to open.

Conductivity

Conductance is the reciprocal of resistance, which depends on the receptivity constant of the material. Receptivity is the resistance of a conductor having unit cross section and unit length. Conductivity is the reciprocal of the receptivity. Its units are 1/ohm-cm or ohm/cm, or 1/ohm-circular mils/ft

Conductor

That part of an electrical circuit whose resistance relative to the balance of the circuit is zero. For example, in a circuit consisting of a light bulb and a battery, connected together with wire, the wire is referred to as the conductor.

Converter

An electrical device that converts one type of electrical energy into another. Battery chargers convert AC power to DC to charge the battery, inverters convert DC power into AC, both are converters. Often used in RV industry to mean a power supply that runs the domestic DC loads when shore power is available.

Coordination

The ability of the protector with the lowest rating in a cascade arrangement to trip before those with higher ratings (See Cascade Circuit).

Coulomb

see amperage
The measurement unit of electric charge, which is determined by the number of electrons in excess (or less than) the number of protons. Classically a charge of 1 coulomb = 6.25×10^{18} electrons. The meter-kilogram-second unit of electrical charge equal to the quantity of charge transferred in one second by a steady current of one ampere.

Cranking (Starting)

Normally associated with "cranking current" which is the current required by the starter circuit prior to engine starting. The cranking current varies significantly during the starting cycle. Initially, there is a large surge of current required to overcome the inertia and compression of the engine. This surge can be two to four times the average cranking current. Once the engine is turning there are peaks and valleys as the pistons go through the compression and exhaust cycles. The cranking current rating is used for sizing batteries, cables, and battery switches.

Current

see amperage
Current is a flow of electrical charge carriers, usually electrons or electron-deficient atoms. The common symbol for current is the uppercase letter I. The standard unit is the ampere, symbolized by A. Physicists consider current to flow from relatively positive points to relatively negative points; this is called conventional current or Franklin current. Electrons, the most common charge carriers, are negatively charged. They flow from relatively negative points to relatively positive points. Electric current can be either direct or alternating. Direct current (DC) flows in the same direction at all points in time, although the instantaneous magnitude of the current might vary. In an alternating current (AC), the flow of charge carriers reverses direction periodically. The number of complete AC cycles per second is the frequency, which is measured in hertz. An example of pure DC is the current produced by an electrochemical cell. The output of a power-supply rectifier, prior to filtering, is an example of pulsating DC. The output of common utility outlets is AC.

Current Limitation

A protective device that reduces the available short circuit peak current to a lesser value.

Current Rating

The maximum current in amperes that a device will carry continuously under defined conditions without exceeding specified performance limits.

Current Transformer

see ammeter
The "CT", as current transformers are commonly referred to, is used by AC ammeters to "sense" current flow in a wire in an AC circuit. It is a toroidal coil of wire through which a wire whose current we wish to measure is passed. It is normally encapsulated and looks like a "doughnut", which is how electrician's commonly refer to it. The doughnut has two wires coming out of it, which are connected to the AC ammeter. As current flows in the AC wire we wish to measure, it induces a current flow in the current transformer. The magnitude of the current varies directly with the current flowing in the AC wire. Current transformers are rated by the number of maximum amps that can flow in the measured wire and the current generated, by the CT, at that current flow. For example: A 50:5 CT is rated for 50 amps flowing in the measured wire, and it generates 5 amps of current as a consequence.

D

Delay

A difference in time between the initiation of an event and its occurrence, or between an event's observation and enunciation of it. This is usually used to refer to the time between the application of overcurrent to a fuse or circuit breaker and the time when the device opens.

Derating

A decrease in a device's rating, usually amperage, due to its application in ambient conditions different from those in which it was tested or for which it was designed originally.

dielectric strength

The maximum voltage stress that a material can withstand without rupture.

Digital

A digital signal is one which has only two valid values denoted as 1 or 0. Commonly these are equated to distinctly different voltage. For example: A voltage of +5V would equal a 1 and a voltage of 0V would equal a 0. A digital meter is one that displays values as numerical values rather than as the position of a meter on a relative scale.

Technical Glossary

Direct Current (DC)

An electric current that always flows in the same direction. The magnitude may vary but the current direction is always the same. Commonly referred to as DC. Examples of direct current sources are batteries, fuel cells, and photovoltaic cells. DC sources such as battery chargers and alternators actually use rectified AC current as the source.

Discharge

Refers to the consumption of energy from a battery, or to the electrostatic discharge associated with a lightning bolt, capacitor, etc.

Double Pole

Indicates a switch, relay, or circuit breaker with two separate conductive paths, which are opened or closed when the device is operated.

Duty, Continuous

The requirement that demands operation at a constant load for an indefinite period of time.

Duty, Intermittent

The requirement that demands operation for alternate intervals of (1) load/no load; (2) load/rest; or (3) load/no load/rest.

E

Earth

The third planet from the sun in Astronomy, but in electrical terms it refers to a connection, which is made to a conductor that is connected to the planet Earth. In grounded electrical systems there is a connection, which is a copper rod or some other highly electrically conductive connection, to the actual Earth. This is to ensure a safe conductive path for a short circuit, which in turn helps prevent electrocution.

Electron see coulomb

A negatively charged subatomic particle, that is either free (not attached to any atom), or bound to the nucleus of an atom. In electrical conductors, current flow results from the movement of free electrons from atom to atom individually, and from negative to positive electric poles in general. The charge on a single electron is considered as the unit electrical charge. It is assigned negative polarity. Electrical charge quantity is not usually measured in terms of the charge on a single electron, as this is an extremely small charge. Instead, the standard unit of electrical charge quantity is the coulomb, symbolized by C, representing about 6.25×10^{18} electrons.

Electromotive Force (EMF)

Commonly referred to as voltage, electromotive force is the energy per unit of charge that is supplied by a source of electrical energy such as a battery, charger or alternator.

Electromagnetic Interference (EMI).

Noise generated by a load (typically by electrical switching action). Usually specified as meeting agency limits for conducted EMI (noise reflected back onto the power bus) or radiated EMI (noise emitted into the area surrounding a device).

Energy see power

The classically simple definition is, the capacity to do work. Energy may be manifested as, mechanical motion, thermal heat, or electrical power, which is consumed, radiated, dissipated, or stored over a period of time. The energy in a direct-current circuit is equal to the product of the voltage in volts, the current in amperes, and the time in seconds. The units for energy are Watt-hours. In alternating current (AC) circuits, the expression for energy is more complex.

Effective or RMS value

The value of alternating current that will produce the same amount of energy in a resistance as the corresponding value of direct current.

F

Fault

A defect in the normal circuit configuration, usually due to unintentional grounding. Commonly referred to as a short circuit.

Fault Current

The current that may flow in any part of a system under fault conditions.

Feeder

All circuit conductors between the service entrance equipment and the final branch circuit protector.

Field

Typically refers to a magnetic field. Specifically used when discussing the rotating electro-magnetic field associated with an alternator. By varying the field current, thus its strength, the output of the alternator may be controlled.

Frequency see hertz

For an oscillating or varying current, frequency is the number of complete cycles per second in alternating current direction. The standard unit of frequency is the hertz, abbreviated Hz. If a current completes one cycle per second, then the frequency is 1 Hz; 60 cycles per second equals 60 Hz (the standard alternating-current utility frequency).

Fuse

Safety device, consisting of a strip of low-melting-point alloy, which is inserted in an electric circuit to prevent excess current from flowing. If the current becomes too high the alloy strip melts, opening the circuit.

G

Generator

A rotating machine capable of generating electrical power. In the narrow definition generator refers to a DC machine and alternator refers to an AC machine. However, in common use the term generator is used to refer to AC machines as well.

Green Wire

The green wire is the non-current carrying safety grounding wire in an AC system in the United States. It is connected to an exposed metal part in the electrical system to provide a path for fault current in the case of a short circuit.

Ground Fault

GFI (Ground Fault Interruptor)

GFI is generic term referring to both GFCI and GFP

GFCI (Ground Fault Circuit Interruptor) see GFI

A device intended for the protection of personnel that functions to de-energize a circuit, or portion thereof, within an established period of time when a current to ground exceeds some predetermined value that is less than that required to operate the overcurrent protective device of the supply circuit.

GFP (Ground Fault Protector) see GFI

A device intended to protect equipment by interrupting the electric current to the load when a fault current to ground exceeds some predetermined value that is less than that required to operate the overcurrent protection device of that supply circuit.

ground, ground conductor

A point in a circuit which is at zero potential with respect to the Earth, or which is at the lowest potential in the system, (as with a floating ground).

grounding, grounding conductor

The AC conductor, not normally carrying current, used to connect the metallic non-current carrying parts of electrical equipment to the AC system and engine negative terminal, or its bus, and to the shore AC grounding conductor through the shore power cable. This term can also refer to the normally non-current carrying conductor used to connect metallic non-current carrying parts of direct current devices to the engine negative terminal, or its bus, to minimize stray current corrosion.

Grounded

The AC current carrying conductor that is intentionally maintained at ground potential, also called neutral.

H

Hertz see frequency

Hertz is a unit of frequency of one cycle per second. It replaces the earlier term of "cycle per second (cps)." The abbreviation for Hertz is Hz.

High Inrush (High-inrush)

A load that exhibits, upon application of power, a steep wave front transient of very high current amplitude for a short duration.

Hot

Hot usually refers to the ungrounded current carrying conductors in an AC system. These would typically have a voltage of 120V or 240V in the United States. The term Hot is also used to describe a circuit that is energized, and has a potential greater than ground.

I

Inductance

An effect in electrical systems in which electrical currents store energy temporarily in magnetic fields before that energy is returned to the circuit.

Instantaneous Trip

Indicates that no intentional delay is purposely introduced in the opening time of a protector.

Interrupt Rating (AIC)

The fault current that a device, normally a fuse or circuit breaker is capable of interrupting without damage.

interrupting capacity

The maximum fault current that can be interrupted by a protective device without failure of the device.

inverter

An inverter converts DC power stored in a battery to AC power which is used by most household appliances.

IP ignition protection

Devices, which operate in a potentially explosive environment, must be ignition protected. This would include engine rooms with gasoline engines. There is a very specific set of tests which a device must pass to claim ignition protection. They include operating safely in an explosive mixture of propane and air.

isolation transformer

A transformer that is inserted in series with the incoming AC power to provide a magnetic coupling for power between the ship's systems and the AC grid. By magnetically coupling the power there is no direct connection by wires, which isolates the ships AC system from the AC grid.

L

Let-Through Current

The actual fault current passing through a protective device as compared to the current available to the device.

Line see load

The conductors that are at the supply of energy to a circuit. Line normally refers to the current carrying non-grounded conductor.

Line Loss see voltage drop

The power loss that occurs due to amperage flowing through the resistance of conductors over their length.

Listed (UL Listed)

Indicates that a device or component has met certain specifications as set forth by Underwriters Laboratory. Further, it means that the device or component has been tested for conformance and 'listed' with UL so it can use the UL logo and claim conformance to the specification.

Load see line

A device that consumes power and does work.

Technical Glossary

M

Make (Rating)

The current that a breaker, switch, or relay can connect without damaging the device.

Make Before Break

Describes a switch action that connects the new circuit before disconnecting the old. This type of switch action is required for battery switches in order to avoid an open circuit for the engine alternator, which can cause extreme voltages that can damage the alternator and accessory electronics.

N

NEC see National Electrical Code

NEMA

National Electrical Manufacturers Association

National Electrical Code (NEC)

The NEC is developed and maintained by the National Fire Protection Association which describes how residential, commercial, and RV electrical systems must be installed. The NEC is adopted, sometimes with revision, by states that also adopt the Uniform Building Code. Electrical inspections required by most building permits follow the NEC. While not required aboard boats, the NEC is a valuable guide to safe electrical systems. The goal of the NEC is personal safety and fire prevention.

Neutral (Ground) see single phase

The grounded current carrying conductor in a single phase, four wire, 120/240V AC system.

Neutral-to-Ground Bonding

Connecting the ground and the neutral together via an electrical conductor.

Nuisance Trip

A circuit breaker or fuse, which trips or blows without the circuit actually being overloaded. This may be due to a surge current which requires a slow tripping breaker or a slow blow fuse. An electrical circuit in which the positive connections are all in common and the negative connections are all in common. The voltage of the system appears across each branch of the circuit. The current varies as required by each load or source.

O

Ohm

The unit for resistance equals $V/I = \text{volt/current}$. The unit of resistance is the ohm, symbol Ω , the Greek letter Omega.

Ohm's law

States that the ratio of the EMF (Electromotive Force) applied to a closed circuit to the current in the circuit is a constant. That constant is the resistance of the circuit. It may be stated as $V = IR$ (or $E = IR$, using E as the abbreviation of EMF whose units are volts). The unit of resistance is the ohm.

Open

Indicates a condition in an electric circuit in which there is a break in the conductive path. The break may be intentional such as an open switch or relay or it may be unintentional such as a broken wire or a blown fuse. In any case, the continuous conductive path required for an electric circuit is not available.

Overcurrent

When the current in a circuit exceeds the rating of the devices or conductors in it. Fuses and circuit breakers protect from overcurrent by opening the circuit if such a condition exists and persists.

Overload Current

The current value in excess of the rated current of the protective device.

Overload Rating (OL)

Designates whether the protector or family of protectors has been tested for general use or motor-starting applications:

OL0 - tested at 1.5 times amp rating for general use

OL1 - tested at 6 times sac rating or 10 times DC rating for motor starting application.

P

Panelboard

A collection of circuit breakers, switches, and instrumentation installed into a panel, which provides the central point for power distribution and monitoring for the electrical system. May also refer to a smaller panel, which is located remotely from the main panel, which is used to supply loads in the adjacent area. "Panelboard" is a term generally used only by NEC. In the marine industry they are usually called "panels", or "circuit breaker panels", or "distribution panels".

Parallel Circuit

Pigtail

Wires which protrude from a device to connect it to the circuit. Often used in encapsulated products. Sometimes refers to a method of hooking up circuits in which a group of conductors are connected together and then one wire is connected to the circuit, this is done in order to simplify wiring.

Polarity

Refers to the electrical charge, which may be positive or negative. It also refers to the positive and negative terminals of a battery or load in a DC system. In AC systems it refers to the connections made to the hot and neutral. There is often a reverse polarity light that indicates if the neutral and hot are reversed.

Polarized System

An electrical system in which the positive and negative or the hot and neutral must be connected in a particular way and cannot be switched. Sometimes there are mechanical preventions to insure the correct polarity. For example, in an AC plug the physical configuration of the plug and receptacle force a polarized connection.

Pole see toggle

Indicates a conductive path in a switch or relay. Switches that are single pole have one conductive path; switches that are two pole have two conductive paths. Also refers to the magnetic poles on an electromagnet or a permanent magnet

Potential

The voltage across a circuit element. Implies the potential to do work.

Power

Electrical power is the rate at which electrical energy is converted to another form, such as motion, heat, or an electromagnetic field. The common symbol for power is the uppercase letter P. The standard unit is the watt, symbolized by W. In utility circuits, the kilowatt (kW) is often specified instead; 1 kW = 1000 W. Power in a direct current (DC) circuit is equal to the product of the voltage in volts and the current in amperes. This rule also holds for low-frequency alternating current (AC) circuits in which energy is neither stored nor released. At high AC frequencies, in which energy is stored and released (as well as dissipated or converted), the expression for power is more complex. In a DC circuit, a source of V volts, delivering I amperes, produces P watts according to the formula: $P = VI$ When a current of I amperes passes through a resistance of R ohms, then the power in watts dissipated or converted by that component is given by: $P = I^2 R$ When a potential difference of V volts appears across a component having a resistance of R ohms, then the power in watts dissipated or converted by that component is given by: $P = V^2 / R$

Power Factor

In an AC circuit loads other than resistance shift the phase angle between the voltage and the current. This shift is the result of energy being stored and released in an inductor for example. To calculate the power consumed one must consider this phase shift. We do so by using the following formula $P = VI \cos \phi$, where ϕ is the difference in phase angle between the voltage and current. $\cos \phi$ is called the power factor. For resistive loads the power factor is equal to 1 because the phase angle equals 0. For pure inductive loads the power factor is 0 because the phase angle is $+90^\circ$.

R

Recognized (UL Recognized)

A device that is UL Recognized differs from a device that is UL Listed. A Recognized device is expected to be installed within a larger assembly by a manufacturer, not in the field, and this larger assembly is then expected to be tested by UL. The UL Recognition then allows UL to skip testing of the specific embedded Recognized component. UL Recognition has little value for end users installing devices in the field.

Rectifier

A device that allows current to flow in only one direction, such as a diode. Used to convert, or rectify AC current into DC.

Regulator (Voltage Regulator)

A device, which uses a feedback loop to control the output of an alternator or other source. By measuring the output voltage and controlling the alternator field current, for example, the regulator is able to continuously adjust the alternator output to the desired voltage.

Resistance

The opposition to the flow of current in an electric circuit as defined by Ohm's law. The unit of resistance is the ohm, symbol Ω , the Greek letter Omega.

Reverse Polarity

Describes a situation where the neutral and hot wires of an AC system are reversed. Most AC panels have an indicator to annunciate this condition, as it can be very dangerous.

RMS (Root-Mean-Square)

Root-mean-square (RMS) refers to the most common mathematical method of defining the effective voltage or current of an AC wave. To determine RMS value, three mathematical operations are carried out on the function representing the AC waveform:

(1) The square of the waveform function (usually a sine wave) is determined.

(2) The function resulting from step (1) is averaged over time.

(3) The square root of the function resulting from step (2) is found.

In a circuit whose impedance consists of a pure resistance, the RMS value of an AC wave is often called the effective value or DC-equivalent value. For example, if an AC source of 100 volts RMS is connected across a resistor, and the resulting current causes 50 watts of heat to be dissipated by the resistor, then 50 watts of heat will also be dissipated if a 100-volt DC source is connected to the resistor. For a sine wave, the rms value is 0.707 times the peak value, or 0.354 times the peak-to-peak value. Household utility voltages are expressed in RMS terms. A so-called "117-volt" AC circuit has a voltage of about 165 volts peak (pk), or 330 volts peak-to-peak (pk-pk).

S

Safety Green (Ground) Wire

The non-current carrying conductor in a three wire 120V or four wire 240V AC circuit, it provides a safe path for fault current. See also green ground wire.

Self-Limiting

A device whose ability to limit output power regardless of input power is intrinsic to its design.

Short Circuit

A conductive path of zero resistance. Typically refers to an unintentional connection between two conductors of opposite polarity. If a voltage is applied to a short circuit the current becomes very large and can start a fire, thus the need for short circuit, or overcurrent, protection in the form of fuses or circuit breakers.

Short-Circuit Current Rating (SC)

The short-circuit current rating in kiloamperes (kA), followed by a letter and number designating the test conditions and any calibration following the short-circuit test as defined below:

C - a short circuit test was conducted with series overcurrent protection

U - a short circuit test was conducted without series overcurrent protection

1 - a recalibration test and dielectric strength test were not conducted as part of short circuit testing

1a - the supplementary protector was permanently open after the short -circuit test. A dielectric strength test and a voltage withstand test were conducted. (CSA only)

2 - a recalibration test and dielectric strength test were conducted as part of short-circuit testing

3 - a recalibration test, dielectric strength test and voltage withstand test were conducted as part of short circuit testing. (CSA only) Note: The C3 rating is not available.

Technical Glossary

Sine Wave

A waveform that can be expressed as the graph of the equation $y = \sin x$. The utility AC power is a sine wave.

Single Phase

The typical 120/240V AC system in the United States is a single phase system, meaning that the current flow in the two conductors is in phase or that they both cross zero at the same time.

Stray Current

Unwanted current flows which occur due to a partial short circuit.

surge

A large amount of current during the initial starting phase of a motor for example.

Surge Capacity

The measurement of the ability to withstand surge currents without damage.

Switch

An electro-mechanical device that is intended to open an electrical circuit and thus turn a load or source on or off.

Switchboard see panel board

T

Terminal

A connection point or device for an electrical circuit. A terminal strip is a series of screws which may or may not be in common to which wires are connected. Also refers to the connecting device which may be crimped on the end of a wire to enable it to be connected to the circuit with a screw, such as a ring terminal.

Terminal Studs

A threaded bolt onto which ring terminals may be placed and then fastened with a nut. Normally used for high current connections.

Thermal

Thermal most commonly refers to a thermal circuit breaker, which uses the thermal effect of excess current flow to create differential expansion in a bi-metallic blade to open a circuit.

time-current curve see delay

A curve which depicts the relationship between the amount of current a fuse or breaker can withstand with respect to time.

Time Delay

The introduction of an intentional delay to the opening function of a protective device.

Toggle see pole

A switch which has a handle type actuator that can be placed in, at the most, three positions.

Total Clearing Time

The time elapsing from initiation of overload current to final current interruption.

Transfer Switch, AC see selector switch, source isolation

An electrical relay or manual switch which selects an AC source alternative, such as a generator, shore power, or inverter.

Transformer, isolation see isolation transformer

Trip Free

A circuit breaker designed to trip when subjected to a fault current, even if the reset lever is held in the ON position.

Tripping Current (TC)

Tripping current is coded as a percentage of the amp rating. Codes for UL & CSA products:

TC0 - tripping current is less than 125% of amp rating

TC1 - tripping current is between 125 and 135% of amp rating

TC2 - tripping current is more than 135% of amp rating

TC3 - tripping current is standardized at 135% and at 200% of amp rating (CSA only)

U

Ultimate Trip Current

The minimum value of current that will cause tripping of a protective device.

Ungrounded Conductor

Any conductor that is not connected to the Earth ground system.

V

Volt (Voltage)

The unit of electric potential and electromotive force, equal to the difference of electric potential between two points on a conducting wire carrying a constant current of one ampere when the power dissipated between the points is one watt.

Voltage Drop

Conductor's voltage reduction due to resistance.

Voltage Rating

The maximum voltage at which a device is designed to operate.

Voltage Trip

A protective device that is factory calibrated to trip at a predetermined voltage value.

W

Watt

The measurement of electrical power. One watt is equal to one ampere of current flowing at one volt. Watts are typically rated as amps x volts; however, amps x volts, or volts-amps (v-a) ratings and watts are only equivalent when powering devices that absorb all the energy such as electric heating coils or incandescent light bulbs.

Wire Sizing

The process of selecting the appropriate sized conductor for the amount of current to be carried while considering the length of the circuit.

Withstand Voltage

The maximum voltage level that can be applied between circuits or components without causing a breakdown.

Authorized Sales Representatives and Distributors

Click on a region of the map below to find your local representatives and distributors or visit www.carlingtech.com/findarep.



About Carling

Founded in 1920, Carling Technologies is a leading manufacturer of electrical and electronic switches and assemblies, circuit breakers, electronic controls, power distribution units, and multiplexed power distribution systems. With six ISO9001 and IATF16949 registered manufacturing facilities and technical sales offices worldwide, Carling Technologies Sales, Service and Engineering teams do much more than manufacture electrical components, they engineer powerful solutions! To learn more about Carling please visit www.carlingtech.com/company-profile.

To view all of Carling's environmental, quality, health & safety certifications please visit www.carlingtech.com/environmental-certifications.



European Headquarters

Carling Technologies LTD

4 Airport Business Park, Exeter Airport,
Clyst Honiton, Exeter, Devon, EX5 2UL, UK

Phone: Int + 44 1392.364422

Email: ltd.sales@carlingtech.com

Worldwide Headquarters

Carling Technologies Inc.

60 Johnson Avenue,
Plainville, CT 06062 USA

Phone: 860.793.9281

Email: sales@carlingtech.com

Asia-Pacific Headquarters

Carling Technologies, Asia-Pacific LTD.,

Suite 1607, 16/F Tower 2, The Gateway, Harbour City, 25
Canton Road, Tsimshatsui, Kowloon, Hong Kong

Phone: Int + 852-2737-2277

Email: sales@carlingtech.com.hk

WWW.CARLINGTECH.COM

