

# PRESSURE SENSORS

# OPERATING PRINCIPLES

## ■ Semi conductor type pressure sensors

〈Operation〉

1. The pressure sensor utilizes the piezoresistive properties of a semiconductor which exhibits change in the resistance when stress is applied.
3. Piezoresistors are created on the surface of the single crystal silicone by a heat diffusion process and sense stress when pressure acts on the diaphragm.

〈Output〉

The output obtained is change in the voltage that is proportional to the applied pressure and is approximately 100 mV at the rated pressure. Measurement accuracy is increased by adding temperature compensation resistors which are contained in the pressure sensor.

## ■ Semi conductor type pressure sensors

〈Operation〉

2. The pressure sensing chip is made of a single crystal silicone and measures approximately  $4 \times 3 \times 1.7$  mm. The chip has a diaphragm which deforms when pressure is applied.
4. There are four piezoresistors forming a wheatstone bridge which is excited by constant current. When pressure is applied, voltage signals proportional to the pressure can be obtained from the output terminals.

Cross-section view

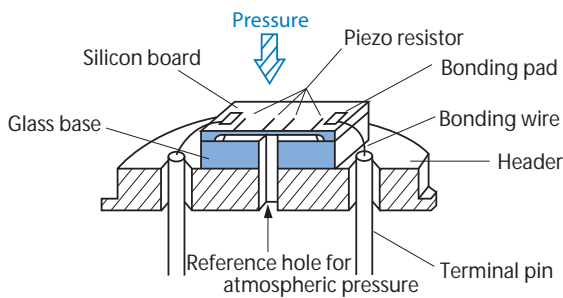

Electrical schematics

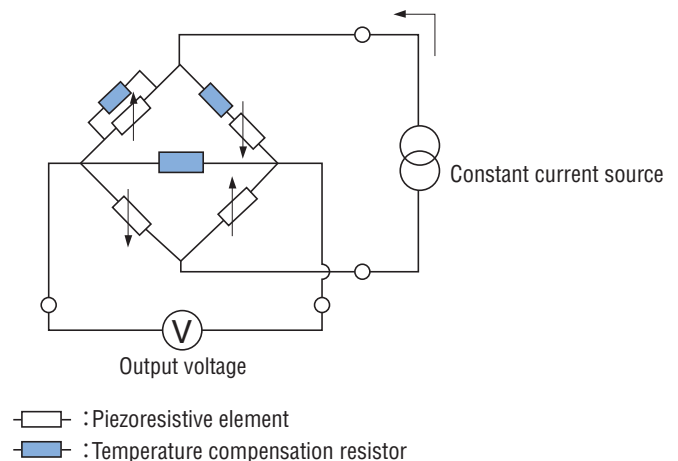

# OPERATING PRINCIPLES

## PRESSURE SENSORS

### ■ Thin-film type pressure sensors

〈Operation〉

1. The structure of our thin film pressure sensor is that insulation film is formed on the metal diaphragm, and thin film gauges are arranged on the insulation film.
3. Four thin film resistors, forming a Wheatstone bridge, is driven by constant voltage and produce output voltage in proportionate to the applied pressure.

2. If pressure is applied to the sensor, the metal diaphragm is altered. In turn, the thin film gauge on the metal diaphragm is altered and causes a change in its resistance.

〈Output〉

Output voltage is produced in proportion to the applied voltage. It is about 30 mV if rated pressure is applied.

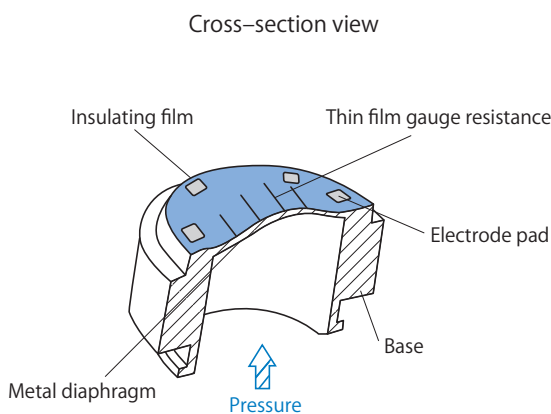

Electrical schematics

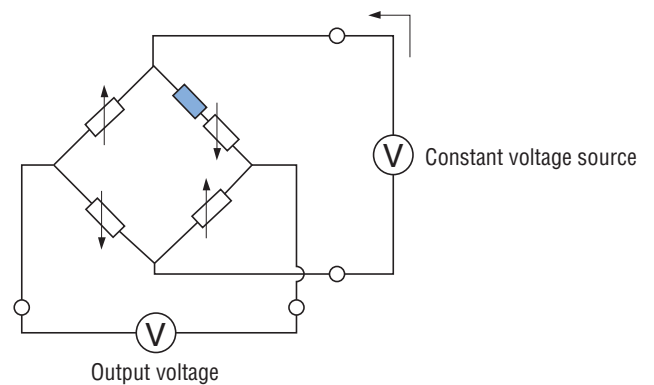

- : Thin film gauge resistor
- : Zero compensation resistor