

# Mounting Procedures

## ■ Mounting the Switch on Panel

- (1) Sandwich a panel with two nuts provided and tighten the nuts. Usually, the panel will not be damaged and the even bushing height will be ensured when tightening the nut at the back of the panel, while holding the upper nut. (Fig.1)

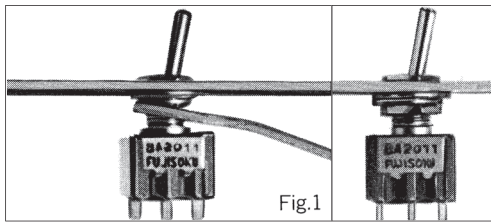

- (2) When mounting the switch on a thick panel, the switch can be mounted with a single nut since the seat is provided at the base of the bushing (excluding **8B** and **8Y** types). (Fig.2)

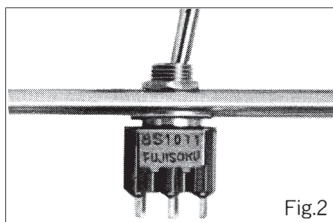

- (3) The locking lever type (**8E**) should be mounted by allowing 1 to 1.5 mm from the top surface of bushing. Neglecting this caution may result in operation failure. (Fig.3)

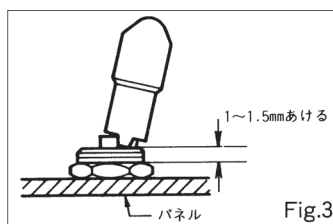

- (4) Do not turn the switch body to fasten it onto the panel. (Fig.4)

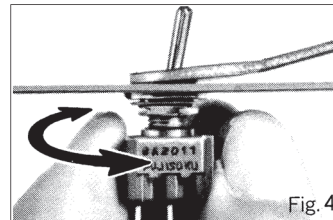

- (5) To reposition the switch, loosen the nut on the back of the panel, move the switch to the desired position and retighten the nut. Be careful rotating the switch body with the nut fastened will damage the switch.

- (6) After mounting the switch, do not place the device in such a way that the device weight will be applied on the knob of the switch. Do not press the knob of toggle switch or lever switch, or the button of the pushbutton switch with a load exceeding the specified load.



- (7) To replace the cap of the lever lock toggle switch (**8E** and **ATLE** types), set the knob in the locked position and tighten the cap with 9.8 to 14.7 N · cm torque.

## ■ Mounting Procedures of Accessory Parts

- (1) The accessory parts should normally be mounted in the order as shown in Fig. A at the right.

Tightening torque

M6 and 1/4"-40 THD screw

: 49 N·cm

M12 and 15/32"-32 THD screw

: 137 N·cm

In particular, when the switch without bushing is mounted on the panel, apply hex nuts on both sides of the panel. Mounting the switch with the hex nut on the top side only will cause failure.

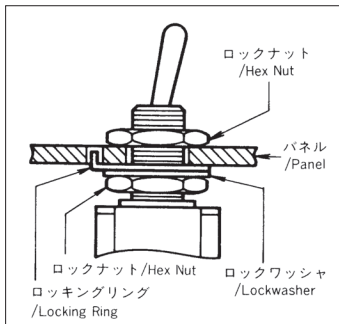

(Fig.A)

- (2) For the 8F and 8P waterproof types, use the O-ring under the panel as shown in Fig. (B) at the right.

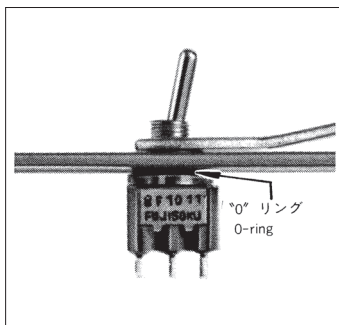

(Fig.B)

- (3) Use the locking ring provided to mount the switch in a desired direction.

- (4) Be sure to use the lock washers provided not to allow the hex nut to become loose after tightening. Do not tighten the hex nut more than necessary.

- (5) Effective thickness of mounting panel

For the values of the effective thickness of mounting panel on the **Panel Cut-Out Dimensions** of each Series products, if the locking ring is not used, the thickness can be 1 mm thicker than the specified effective panel thickness since the thickness of the locking ring is 1 mm.