

THE ROLE OF CONNECTORS IN THERMAL MANAGEMENT IN EVs



Efficient thermal management is essential in electric vehicles to ensure safety, performance, and longevity, with connectors playing a vital role in minimizing resistance and supporting reliable power and data transmission. Harwin's BBI connector range, including the Flecto and Kontrol series, offers robust, compact solutions designed to meet the demanding thermal and mechanical requirements of modern EV systems.

INTRODUCTION

Electric vehicles (EVs) are the fastest-growing sector in the automotive industry, not just in the domestic car market but across a range of applications. From agricultural vehicles to buses and trucks, manufacturers are creating electric alternatives to conventional internal combustion engines.

While electric vehicles do not burn conventional fuel to create power, they do still generate heat. The latest generation of electric motors can deliver impressive efficiency, but even the most efficient device will produce unwanted heat. All conductive components possess

electrical resistance, however small, and electric current flowing through them will result in some of the energy being lost as heat.

Heat is therefore a symptom of an inefficient system but also causes other problems. Electric vehicles depend heavily on copper, not only for cable harnesses but also in the construction of electric motors. The electrical properties of copper are affected by temperature, with elevated temperatures causing an increase in resistance. Therefore, unwanted heat will further reduce the efficiency of the

INTRODUCTION (CONT.)

electrical system. High temperatures also adversely affect reliability, as many materials deteriorate quickly at higher temperatures. The result can range from the unwanted oxidation of metals to the softening and deforming of plastic.

Electrical efficiency therefore plays a role greater than simply improving the performance of EVs, and can improve their overall reliability and safety. Managing the thermal load and selecting components that minimise its effects are therefore vital in the world of automotive design.

THERMAL MANAGEMENT IN EV SYSTEMS

Lithium-ion (Li-ion) battery technology is the most common choice for modern electric vehicles. Li-ion offers the best combination of capacity, long life and charging capabilities. The performance of Li-ion batteries is best at mild temperatures. Low temperatures reduce the capacity of a Li-ion battery, and will increase the time it takes to fully charge. In contrast, exposing a Li-ion battery to heat can result in long-term damage. Elevated temperatures accelerate the chemical reactions within the battery, reducing both capacity and efficiency.

Management of heat is of particular importance during the charging cycle. Li-ion batteries are made up of thousands

of individual cells. If an individual cell is damaged, whether due to high temperatures, the ingress of water into the battery or by physical impact, its lower capacity complicates the charging process. With a lower capacity, the individual cell cannot be charged at the same rate as its neighbours. Overcharging a battery has significant consequences including a dangerous situation known as thermal runaway. In this situation, the overcharge raises the temperature of the cell, creating an uncontrollable, self-heating state which, if unchecked, leads to a serious fire. To control this process and monitor the condition of the battery, the Battery Management System (BMS) is used to ensure its safety and reliability.

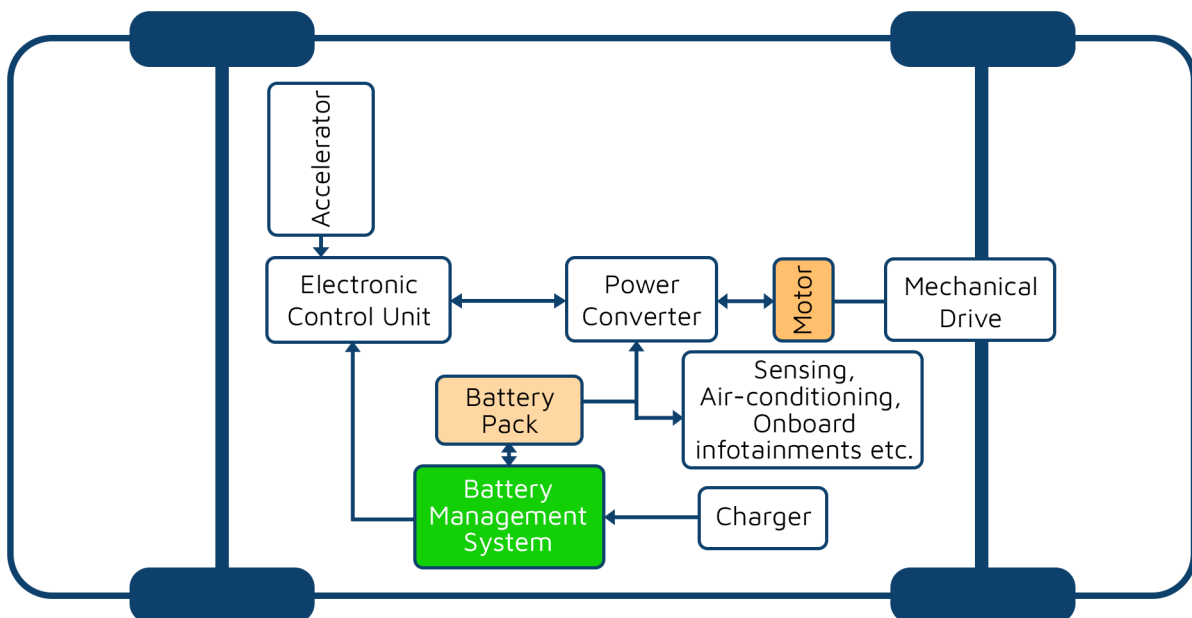

Typical BMS layout

THE ROLE OF CONNECTORS IN ELECTRIC VEHICLES

Connectors play several key roles in ensuring the safety and efficiency of EVs. It is vital that power is carried throughout the EV as efficiently as possible. Power loss within the cable harness is affected by the resistance of the conductors. Minimising the resistance will not only increase the efficiency of the EV, improving the overall performance and range, but lower resistance will result in a lower temperature rise. Connectors use contacts that are designed with the lowest possible contact resistance. Machined contacts are the best solution, providing excellent cross-sectional area for the low contact resistance.

Connectors are also important for the BMS that keeps the battery safe. The BMS receives data from a larger number of sensors arrayed within the battery, and connectors provide the vital link to ensure this information

is transmitted quickly. The large number of channels associated with these sensors requires a connector that is small and provides high signal density. Connectors designed for BMS applications must be compact and offer high pin counts, while also delivering high data rates to transmit information with the lowest possible delay.

Alongside the electrical requirements of automotive connectors, they must be designed to withstand the harsh conditions in which vehicles are used. They must be protected against moisture, dust and dirt, even while exposed to shock and vibration. They require robust locking mechanisms to create a secure connection. These can take the form of screw locking or latch systems to prevent accidental disconnection. Connector reliability is vital due to their role in providing power, and the security of their connections is of paramount concern.

THE HARWIN BBI SOLUTION

The Harwin Flecto and Kontrol connector series are ideal for the high-performance demands of modern electric vehicles (EVs). Part of Harwin's BBI range of board-to-board connectors, they offer robust solutions for power and signal. For signal connections, the Flecto series is available in different pitch options of 0.5mm, 0.635mm and 0.8mm, delivering data rates of 8Gb/s (Gigabits per second), 12Gb/s and 5Gb/s respectively. Fine pitch connectors are often difficult to assemble due to the precision required to align the contacts, so the Flecto series features a floating mount that allows for misalignment during the assembly process. When power connections are required, the F11 series is available in mixed layout options,

combining 0.5mm pitch signal contacts with larger power terminals capable of up to 3 Amps per circuit.

For applications that do not suit a mixed connector layout, the Kontrol series offers a range of 1.27mm pitch board-to-board connectors that combines high-reliability with current ratings of up to 1.2 Amps per contact. Featuring a robust latch for high-vibration environments, their compact size and ease of integration make them ideal for confined spaces, and their blind-mating capability allows for easy assembly applications. Together, Flecto and Kontrol deliver the durability, safety, and efficiency that the rapidly evolving EV market demands.



The Harwin BBI range.



CONCLUSION

As the electric vehicles market grows, efficient thermal management remains essential for delivering performance, safety, and reliability. Managing the heat generated within the EV improves the efficiency of battery systems and makes them more attractive to customers.

Connectors play a critical role in this system, supporting both power and data transmission with minimal resistance and maximum durability. Solutions like the BBi range from Harwin offer robust performance in demanding environments, combining compact design with advanced mechanical and electrical properties. As EV adoption accelerates, smart connector choices will be key to sustainable, high-performance vehicle design.

Get the full technical specs and see how Harwin's BBi connectors can enhance your next EV design here. [🔗](#)