

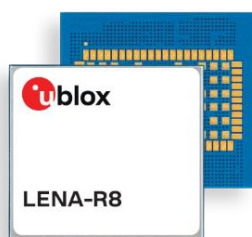

# LENA-R8 series

## Multi-mode LTE Cat 1bis modules System integration manual



### Abstract

This document describes the features and integration guidelines for the LENA-R8 series modules. With 14 LTE bands and four GSM/GPRS bands, these modules offer universal network connectivity and global coverage. The integrated GNSS receiver based on the u-blox M10 platform make the modules ideal for demanding global tracking and telematic applications, enabling simpler, smaller devices with uncompromised GNSS performance. Connectivity and location services are supported and offer customer simple and efficient solution for cloud-based services such as CaaS and LaaS.

# Document information

<b>Title</b>	<b>LENA-R8 series</b>	
<b>Subtitle</b>	Multi-mode LTE Cat 1bis modules	
<b>Document type</b>	System integration manual	
<b>Document number</b>	UBX-22015376	
<b>Revision and date</b>	R03	17-Apr-2023
<b>Disclosure restriction</b>	C1-Public	

<b>Product status</b>	<b>Corresponding content status</b>	
<b>Functional sample</b>	Draft	For functional testing. Revised and supplementary data will be published later.
<b>In development / Prototype</b>	Objective specification	Target values. Revised and supplementary data will be published later.
<b>Engineering sample</b>	Advance information	Data based on early testing. Revised and supplementary data will be published later.
<b>Initial production</b>	Early production information	Data from product verification. Revised and supplementary data may be published later.
<b>Mass production / End of life</b>	Production information	Document contains the final product specification.

This document applies to the following products:

<b>Product name</b>	<b>Type number</b>	<b>Modem version</b>	<b>Application version</b>	<b>PCN reference</b>	<b>Product status</b>
LENA-R8001	LENA-R8001-00C-00	02.00	A01.07	UBX-22035617	Engineering sample
LENA-R8001M10	LENA-R8001M10-00C-00	02.00	A01.22	UBX-23003229	Engineering sample

u-blox or third parties may hold intellectual property rights in the products, names, logos and designs included in this document. Copying, reproduction, modification or disclosure to third parties of this document or any part thereof is only permitted with the express written permission of u-blox.

The information contained herein is provided "as is" and u-blox assumes no liability for its use. No warranty, either express or implied, is given, including but not limited to, with respect to the accuracy, correctness, reliability and fitness for a particular purpose of the information. This document may be revised by u-blox at any time without notice. For the most recent documents, visit [www.u-blox.com](http://www.u-blox.com).

Copyright © u-blox AG.

# Contents

<b>Document information</b> .....	<b>2</b>
<b>Contents</b> .....	<b>3</b>
<b>1 System description</b> .....	<b>6</b>
1.1 Overview.....	6
1.2 Product features .....	6
1.3 Architecture .....	8
1.4 Pin-out .....	9
1.5 Operating modes.....	14
1.5.1 Overview.....	14
1.5.2 Cellular operating modes .....	14
1.5.3 GNSS operating modes .....	15
1.6 Cellular power management.....	17
1.6.1 Cellular supply input (VCC) .....	17
1.6.2 Cellular RTC supply input / output (V_BCKP).....	21
1.6.3 Cellular generic digital interfaces supply output (V_INT).....	21
1.7 Cellular system function interfaces .....	22
1.7.1 Cellular system power-on.....	22
1.7.2 Cellular system power-off .....	23
1.7.3 Cellular system reset .....	25
1.8 Cellular antenna interface.....	25
1.8.1 Cellular antenna RF interface (ANT) .....	25
1.8.2 Cellular antenna detection (ANT_DET) .....	26
1.8.3 Cellular antenna dynamic tuning interface (RFCTRL1 / RFCTRL2).....	27
1.9 Cellular SIM interface .....	27
1.9.1 Cellular SIM card / chip interface.....	27
1.10 Cellular serial communication interfaces .....	27
1.10.1 Cellular UART interfaces .....	27
1.10.2 Cellular USB interface .....	29
1.10.3 Cellular I2C interface .....	30
1.11 Cellular audio interface .....	31
1.12 Cellular clock output.....	31
1.13 Cellular General Purpose Input/Output (GPIO).....	31
1.14 Reserved pins (RSVD) .....	32
1.15 GNSS power management.....	32
1.15.1 GNSS supply input (VCC_GNSS) .....	32
1.15.2 GNSS backup supply input (VBCKP_GNSS).....	32
1.16 GNSS antenna interface.....	32
1.16.1 GNSS antenna RF interface (ANT_GNSS).....	32
1.16.2 GNSS LNA or antenna on/off control (ANT_ON) .....	32
1.17 GNSS serial communication interface .....	33

1.17.1	GNSS UART interface .....	33
1.18	GNSS Peripheral Input/Output.....	33
<b>2</b>	<b>Design-in.....</b>	<b>34</b>
2.1	Overview.....	34
2.2	Cellular power management.....	35
2.2.1	Cellular supply input (VCC) .....	35
2.2.2	Cellular RTC supply (V_BCKP) .....	49
2.2.3	Cellular interface supply output (V_INT).....	50
2.3	Cellular system functions interfaces .....	51
2.3.1	Cellular power-on (PWR_ON).....	51
2.3.2	Cellular reset (RESET_N).....	51
2.4	Antenna interfaces .....	52
2.4.1	General guidelines for antenna interfaces .....	52
2.4.2	Cellular antenna RF interface (ANT).....	56
2.4.3	GNSS antenna RF interface (ANT_GNSS).....	60
2.4.4	Cellular and GNSS RF coexistence .....	65
2.4.5	Cellular antenna detection interface (ANT_DET) .....	67
2.4.6	Cellular antenna dynamic tuning interface (RFCTRL1 / RFCTRL2).....	69
2.5	Cellular SIM interface .....	69
2.6	Cellular serial communication interfaces .....	75
2.6.1	Cellular UART interfaces .....	75
2.6.2	Cellular USB interface .....	78
2.6.3	Cellular I2C interface .....	80
2.7	Cellular audio interface .....	83
2.7.1	Cellular digital audio interface.....	83
2.8	Cellular General Purpose Input/Output (GPIO).....	83
2.9	Reserved pins (RSVD) .....	84
2.10	GNSS power management.....	84
2.10.1	GNSS supply input (VCC_GNSS) .....	84
2.10.2	GNSS backup supply input (VBCKP_GNSS).....	85
2.11	GNSS serial communication interface .....	86
2.11.1	GNSS UART interface .....	86
2.12	GNSS Peripheral Input/Output.....	86
2.13	Module placement .....	87
2.14	Module footprint and paste mask .....	88
2.15	Thermal guidelines .....	89
2.16	Schematic for LENA-R8 series module integration.....	90
2.17	Design-in checklist.....	92
2.17.1	Schematic checklist .....	92
2.17.2	Layout checklist .....	93
2.17.3	Antenna checklist.....	93
<b>3</b>	<b>Handling and soldering .....</b>	<b>94</b>

3.1	Packaging, shipping, storage, and moisture preconditioning .....	94
3.2	Handling .....	94
3.3	Soldering .....	95
3.3.1	Soldering paste .....	95
3.3.2	Reflow soldering .....	95
3.3.3	Optical inspection .....	96
3.3.4	Cleaning .....	96
3.3.5	Repeated reflow soldering .....	97
3.3.6	Wave soldering .....	97
3.3.7	Hand soldering.....	97
3.3.8	Rework.....	97
3.3.9	Conformal coating .....	97
3.3.10	Casting.....	97
3.3.11	Grounding metal covers.....	98
3.3.12	Use of ultrasonic processes.....	98
<b>4</b>	<b>Approvals.....</b>	<b>99</b>
4.1	Product certification approval overview.....	99
4.2	US Federal Communications Commission notice.....	100
4.2.1	Safety warnings review the structure .....	100
4.2.2	Declaration of conformity .....	100
4.2.3	Modifications .....	100
4.3	Innovation, Science, Economic Development Canada notice .....	101
4.3.1	Declaration of Conformity.....	101
4.3.2	Modifications .....	102
4.4	European Conformance CE mark .....	103
4.5	UK Conformity Assessed (UKCA) .....	104
4.6	Australian conformance .....	105
<b>5</b>	<b>Product testing .....</b>	<b>106</b>
5.1	Validation testing and qualification .....	106
5.2	Production testing .....	107
5.2.1	u-blox in-line production test .....	107
5.2.2	Production test parameters for OEM manufacturers .....	107
	<b>Appendix .....</b>	<b>109</b>
<b>A</b>	<b>Migration from LARA to LENA-R8 modules .....</b>	<b>109</b>
<b>B</b>	<b>Glossary .....</b>	<b>109</b>
	<b>Related documentation .....</b>	<b>113</b>
	<b>Revision history .....</b>	<b>113</b>
	<b>Contact.....</b>	<b>114</b>

# 1 System description

## 1.1 Overview

LENA-R8 series modules offer simple global LTE Cat 1bis connectivity with fourteen LTE bands and four 2G bands in the small LENA LGA form-factor (30 x 27 mm, 100-pin), which is easy to integrate in compact designs, reducing logistics complexity for IoT devices that may be deployed in different regions requiring different band combinations.

The module series is ideal for value-oriented IoT products, targeting the tracking and telematics markets or other applications requiring broad global coverage. With broad band support and fallback to 2G networks, the modules provide the best possible roaming coverage and make global tracking with a single product SKU possible.

LENA-R8 series modules are highly integrated, providing out-of-the box support for MQTT Anywhere services on the Thingstream platform, enabling seamless global roaming.

The modules can enable a wide range of applications with GNSS positioning requirements, ranging from high performance stand-alone solutions to a simple out-of-box experience via LENA-R8001M10. This product variant includes integrated GNSS receiver based on the u-blox M10 platform, supporting concurrent reception of four GNSS (GPS, GLONASS, Galileo, BeiDou). The cellular modem and GNSS subsystems are accessible via dedicated interfaces for large usage flexibility. Both subsystems can be operated fully independently, facilitating the optimization of usage patterns to achieve the highest performances with the most efficient power consumption.

The modules also support CellLocate, a network-based cellular location service.

LENA-R8 series modules are small in size and pin-compatible with other u-blox form factors, thereby simplifying migration to LTE Cat 1bis from legacy 2G or 3G technologies, which are sunseting.

## 1.2 Product features

Model	Region	Radio Access Technology	GNSS	u-blox services	Interfaces	Features	Grade
		LTE Category LTE FDD bands LTE TDD bands UMTS/HSPA bands GSM/GPRS bands	Internal GNSS receiver External GNSS control via modem	IoT Security-as-a-Service MQTT Anywhere AssistNow software CellLocate®	UART USB 2.0 I2C GPIOs Digital audio	Root of Trust Secure boot / update Embedded MQTT / MQTT-SN TCP/IP, UDP/IP, HTTP/FTP TLS/DTLS Dual stack IPv4 / IPv6 FOAT / FOTA LwM2M 3GPP Power Saving Mode eDRX Last gasp Jamming detection Antenna detection Antenna dynamic tuning Rx Diversity VoLTE CSFB	Standard Professional Automotive
LENA-R8001	Global	1bis 1,2,3,4,5,7,8 38 12,20,28,66 40,41 Quad	•	• • •	• • • •	• • • • • • • • • • • • • • • •	•
LENA-R8001M10	Global	1bis 1,2,3,4,5,7,8 38 12,20,28,66 40,41 Quad	•	• • •	• • •	• • • • • • • • • • • • • • • •	•

• = supported    ■ = voice call setup supported without audio

Table 1: LENA-R8 series main features summary

LENA-R8 series modules include 2 variants:

- The LENA-R8001 modules, integrating a cellular system supporting multi-band LTE Cat 1bis and 2G radio access technologies for global deployments
- The LENA-R8001M10 modules, integrating the same multi-band LTE Cat 1bis and 2G cellular system of LENA-R8001 modules plus a GNSS system based on the ultra-low-power u-blox M10 standard precision concurrent GNSS receiver. As illustrated in [Figure 2](#), the cellular and the GNSS are fully independent subsystems of the module, internally interconnected by dedicated I2C interface, with separate supply inputs and separate accessible interfaces for great flexibility of use.

Voice over LTE (VoLTE) and Circuit-Switched-Fall-Back (CSFB) call setup is supported without audio.

4G LTE	2G GSM/GPRS	GNSS (LENA-R8001M10 only)
3GPP Release 13 LTE Frequency and Time Division Duplex (FDD/TDD)	General Packet Radio Service (GPRS) Time Division Multiple Access (TDMA)	u-blox M10 standard precision receiver with concurrent reception of up to four GNSS
LTE bands: <ul style="list-style-type: none"> <li>• FDD band 12 (700 MHz)</li> <li>• FDD band 28 (700 MHz)</li> <li>• FDD band 20 (800 MHz)</li> <li>• FDD band 5 (850 MHz)</li> <li>• FDD band 8 (900 MHz)</li> <li>• FDD band 4 (1700 MHz)</li> <li>• FDD band 66 (1700 MHz)</li> <li>• FDD band 3 (1800 MHz)</li> <li>• FDD band 2 (1900 MHz)</li> <li>• FDD band 1 (2100 MHz)</li> <li>• FDD band 7 (2600 MHz)</li> <li>• TDD band 40 (2300 MHz)</li> <li>• TDD band 41 (2600 MHz)</li> <li>• TDD band 38 (2600 MHz)</li> </ul>	GSM/GPRS bands: <ul style="list-style-type: none"> <li>• GSM 850</li> <li>• E-GSM 900</li> <li>• DCS 1800</li> <li>• PCS 1900</li> </ul>	GNSS signals: <ul style="list-style-type: none"> <li>• GPS / QZSS L1C/A (1575.42 MHz)</li> <li>• Galileo E1-B/C (1575.42 MHz)</li> <li>• GLONASS L1OF (1602 MHz + <math>k \cdot 562.5</math> kHz, <math>k = -7, \dots, 5, 6</math>)</li> <li>• BeiDou B1I (1561.098 MHz), B1C (1575.42 MHz)</li> </ul> Augmentation systems: <ul style="list-style-type: none"> <li>• SBAS (EGNOS, GAGAN, MSAS, WAAS)</li> <li>• QZSS L1S (SLAS)</li> </ul>
LTE Power Class <ul style="list-style-type: none"> <li>• Power Class 3 (23 dBm)</li> </ul>	GSM/GPRS (GMSK) Power Class <ul style="list-style-type: none"> <li>• Class 4 (33 dBm) for low bands</li> <li>• Class 1 (30 dBm) for high bands</li> </ul>	Protocols: <ul style="list-style-type: none"> <li>• UBX u-blox proprietary</li> <li>• NMEA 2.1, 2.3, 4.0, 4.10 and 4.11 (default)</li> </ul>
Data rate <ul style="list-style-type: none"> <li>• LTE category 1bis: up to 10.3 Mbit/s DL, up to 5.2 Mbit/s UL</li> </ul>	Data rate <ul style="list-style-type: none"> <li>• GPRS multi-slot class 12<sup>1</sup>: up to 85.6 kbit/s DL, up to 85.6 kbit/s UL</li> </ul>	Assisted GNSS services: <ul style="list-style-type: none"> <li>• AssistNow Online</li> <li>• AssistNow Offline</li> <li>• AssistNow Autonomous</li> </ul>

**Table 2: LENA-R8 series LTE, 2G and GNSS characteristics summary**

<sup>1</sup> GPRS multi-slot class 12 implies a maximum of 4 slots in DL (reception), 4 slots in UL (transmission) with 5 slots in total.

### 1.3 Architecture

Figure 1 summarizes the internal architecture of the LENA-R8001 modules.

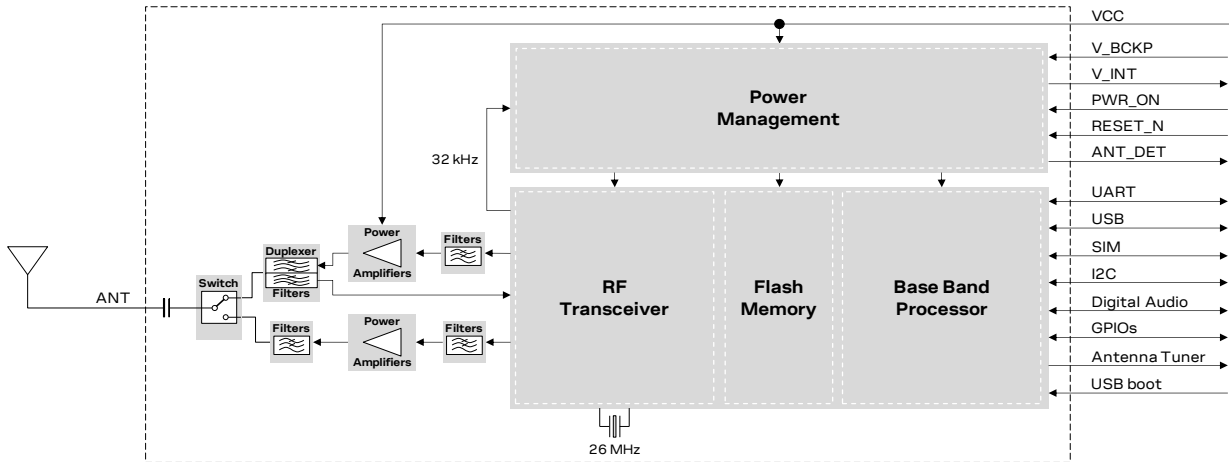

Figure 1: LENA-R8001 modules simplified block diagram

The LENA-R8001-00C product version does not support the antenna tuner interface (**RFCTRL1** and **RFCTRL2** pins) and the digital audio interface (**I2S\_TXD**, **I2S\_RXD**, **I2S\_CLK**, **I2S\_WA** pins)

Figure 2 summarizes the internal architecture of the LENA-R8001M10 modules.

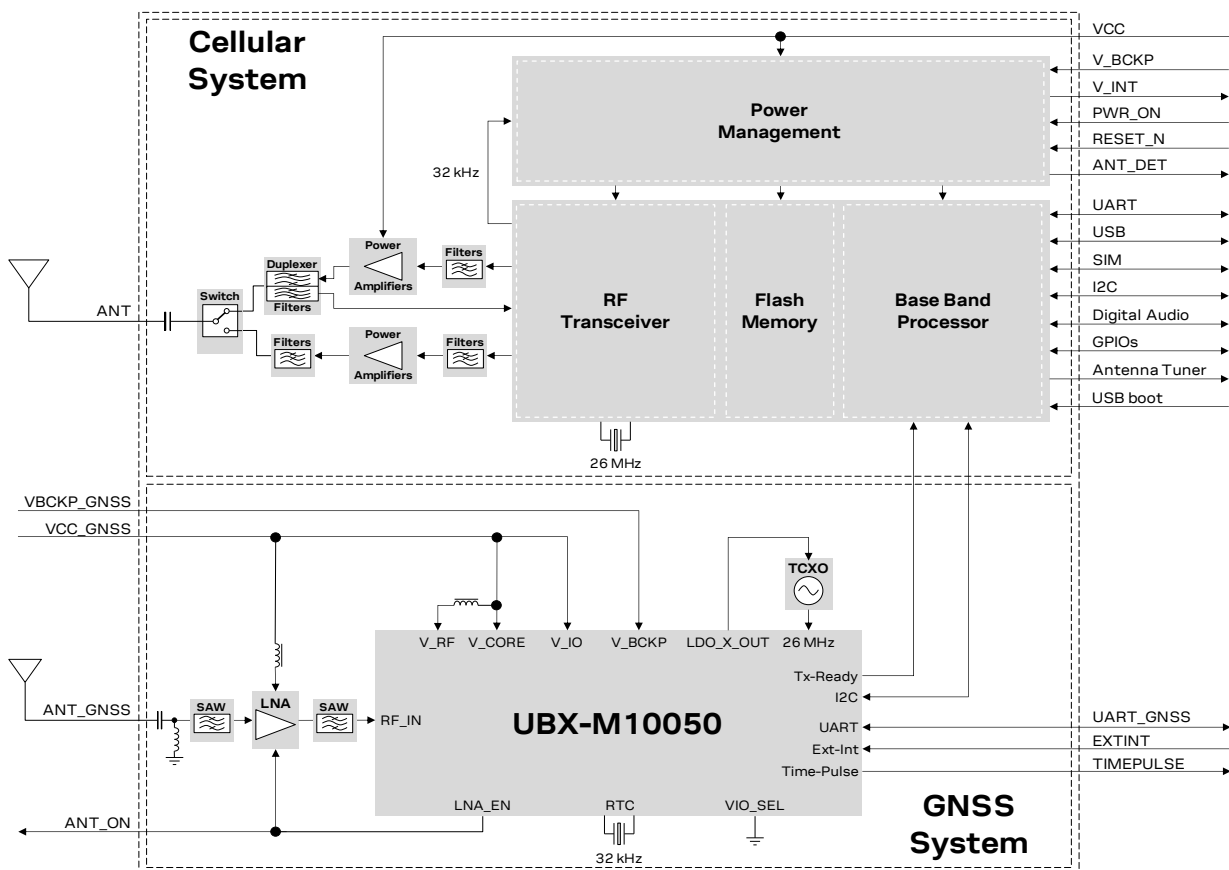

Figure 2: LENA-R8001M10 modules simplified block diagram

LENA-R8001M10-00C product version does not support the antenna tuner interface (**RFCTRL1** and **RFCTRL2** pins), the digital audio interface (**I2S\_TXD**, **I2S\_RXD**, **I2S\_CLK**, **I2S\_WA** pins), and the external I2C interface (**SDA** and **SCL** pins)

LENA-R8 series modules internally consist of the cellular modem system and the GNSS receiver system (available with LENA-R8001M10 modules only), as described herein with more details than the simplified block diagrams of [Figure 1](#) and [Figure 2](#).

### Cellular modem system

The cellular modem system is composed of the following main elements:

- RF section
  - Power amplifiers (PA) amplify the Tx signal modulated by the RF transceiver
  - RF switch connect the antenna port (**ANT**) to the suitable Tx / Rx path
  - SAW RF duplexers and RF filters separate the Tx and Rx signal paths and provide RF filtering
  - 26 MHz crystal oscillator generates the clock reference in active mode or connected mode.
- Baseband processor IC, integrating:
  - Microprocessor and DSP for control functions and digital processing
  - Memory system, which includes NOR flash and PSRAM
  - Dedicated peripheral blocks for control of the USB, SIM and generic digital interfaces
  - RF transceiver performs modulation, up-conversion of baseband signals for transmission, down-conversion and demodulation of the RF signals for reception
- Power management IC, integrating:
  - Voltage regulators to derive all the internal supply voltages from **VCC** module supply input
  - Voltage sources for external use: **VSIM** and **V\_INT**
  - Hardware power on, power off, reset
  - Low power modes support

### GNSS receiver system (LENA-R8001M10 modules only)

The GNSS receiver system of LENA-R8001M10 modules is composed of the following main elements:

- u-blox UBX-M10050-KB concurrent GNSS chipset with SPG 5.10 FW version
- Dedicated supply main input (**VCC\_GNSS**) and backup supply input (**VBCKP\_GNSS**)
- SAW filter in front of an additional Low Noise Amplifier (LNA), followed by another SAW filter
- 26 MHz Temperature-Controlled Crystal Oscillator (TCXO) for the GNSS reference clock
- 32 kHz crystal for the GNSS RTC

## 1.4 Pin-out

[Table 3](#) lists the pin-out of the LENA-R8 series modules, with pins grouped by function.

Function	Pin name	Pin no.	I/O	Description	Remarks
Cellular Power	VCC	51,52,53	I	Cellular supply input	VCC supply circuit affects the RF performance and compliance of the device integrating the module with applicable required certification schemes. See section <a href="#">1.6.1</a> for description and requirements. See section <a href="#">2.2.1</a> for external circuit design-in.
	V_BCKP	2	I/O	Cellular RTC supply input/output	Cellular RTC domain supply input/output. See section <a href="#">1.6.2</a> for functional description. See section <a href="#">2.2.2</a> for external circuit design-in.
	V_INT	4	O	Cellular Generic Digital Interfaces supply output	V_INT = 1.8 V (typ.), generated by internal linear regulator when the module is switched on. Test-Point for diagnostic access is recommended. See section <a href="#">1.6.3</a> for functional description. See section <a href="#">2.2.3</a> for external circuit design-in.
	GND	1,3,5,14,20, 22,30,32, 43,50,54,55, 57,58,60,61, 63-96	N/A	Ground	GND pins are internally connected to each other. External ground connection affects the RF and thermal performance of the device. See section <a href="#">1.6.1</a> for functional description. See section <a href="#">2.2.1</a> for external circuit design-in.

Function	Pin name	Pin no.	I/O	Description	Remarks
GNSS Power	VCC_GNSS	99	I	GNSS supply input	LENA-R8001M10 only. GNSS supply input. See section 1.15.1 for functional description. See section 2.10.1 for external circuit design-in. Internally not connected on LENA-R8001.
	VBCKP_GNSS	100	I	GNSS backup supply input	LENA-R8001M10 only. GNSS backup supply input. See section 1.15.2 for functional description. See section 2.10.2 for external circuit design-in. Internally not connected on LENA-R8001.
	GND	1,3,5,14,20,22,30,32,43,50,54,55,57,58,60,61,63-96	N/A	Ground	GND pins are internally connected to each other. External ground connection affects the RF and thermal performance of the device. See section 1.6.1 for functional description. See section 2.2.1 for external circuit design-in.
Cellular System Control	PWR_ON	15	I	Cellular Power-on input	Internal pull-up to VCC. Test-Point for diagnostic access is recommended. See section 1.7.1 for functional description. See section 2.3.1 for external circuit design-in.
	RESET_N	18	I	Cellular External reset input	Internal pull-up to VCC. Test-Point for diagnostic access is recommended. See section 1.7.3 for functional description. See section 2.3.2 for external circuit design-in.
Antenna	ANT	56	I/O	RF input/output for cellular Tx/Rx antenna	50 $\Omega$ nominal characteristic impedance. Antenna circuit affects the RF performance and compliance of the device integrating the module with applicable required certification schemes. See section 1.8 for description and requirements. See section 2.4 / 2.4.2 for external circuit design-in.
	ANT_DET	59	I	Input for cellular antenna detection	ADC for antenna presence detection function. See section 1.8.2 for functional description. See section 2.4.5 for external circuit design-in.
	ANT_GNSS	31	I	RF input for GNSS Rx antenna	LENA-R8001M10 only. RF input for GNSS Rx antenna, 50 $\Omega$ nominal impedance. See section 1.16.1 for description and requirements. See section 2.4 / 2.4.3 / 2.4.4 for external circuit design-in. Internally not connected on LENA-R8001
	ANT_ON	44	O	GNSS antenna enable	LENA-R8001M10 only. GNSS peripheral output with external GNSS active antenna control and/or external LNA on/off control function, connected to internal LNA. See section 1.16.2 for description and requirements. See section 2.4.3 for external circuit design-in. Internally not connected on LENA-R8001.
Cellular SIM	VSIM	41	O	Cellular SIM supply output	VSIM = 1.8 V / 3 V output as per the connected SIM type. See section 1.9 for functional description. See section 2.5 for external circuit design-in.
	SIM_IO	39	I/O	Cellular SIM data	Internal pull-up to VSIM. See section 1.9 for functional description. See section 2.5 for external circuit design-in.
	SIM_CLK	38	O	Cellular SIM clock	See section 1.9 for functional description. See section 2.5 for external circuit design-in.
	SIM_RST	40	O	Cellular SIM reset	See section 1.9 for functional description. See section 2.5 for external circuit design-in.

Function	Pin name	Pin no.	I/O	Description	Remarks
Cellular UART	RXD	13	O	Cellular UART data output	1.8 V output, UART Circuit 104 (RXD) per ITU-T V.24, supporting AT & data communication, FOAT, Multiplexer. Test-Point and series 0 Ω for diagnostic to be considered. See section 1.10.1.1 for functional description. See section 2.6.1 for external circuit design-in.
	TXD	12	I	Cellular UART data input	1.8 V input, UART Circuit 103 (TXD) per ITU-T V.24, supporting AT & data communication, FOAT, Multiplexer. Internal active pull-up to V_INT. Test-Point and series 0 Ω for diagnostic to be considered. See section 1.10.1.1 for functional description. See section 2.6.1 for external circuit design-in.
	CTS	11	O	Cellular UART clear to send output	1.8 V output, UART Circuit 106 (CTS) per ITU-T V.24. See section 1.10.1.1 for functional description. See section 2.6.1 for external circuit design-in.
	RTS	10	I	Cellular UART ready to send input	1.8 V input, UART Circuit 105 (RTS) per ITU-T V.24. Internal active pull-up to V_INT. See section 1.10.1.1 for functional description. See section 2.6.1 for external circuit design-in.
	DSR	6	O	Cellular UART data set ready output	1.8 V output, UART Circuit 107 (DSR) per ITU-T V.24. Alternatively configurable as AUX UART RTS input <sup>2</sup> . See section 1.10.1.1 for functional description. See section 2.6.1 for external circuit design-in.
	RI	7	O	Cellular UART ring indicator output	1.8 V output, UART Circuit 125 (RI) per ITU-T V.24. Alternatively configurable as AUX UART CTS output <sup>2</sup> . See section 1.10.1.1 for functional description. See section 2.6.1 for external circuit design-in.
	DTR	9	I	Cellular UART data terminal ready input	1.8 V input, UART Circuit 108/2 (DTR) per ITU-T V.24. Internal active pull-up to V_INT. Alternatively configurable as AUX UART data input <sup>2</sup> . See section 1.10.1.1 for functional description. See section 2.6.1 for external circuit design-in.
	DCD	8	O	Cellular UART data carrier detect output	1.8 V input, UART Circuit 109 (DCD) per ITU-T V.24. Alternatively configurable as AUX UART data output <sup>2</sup> . See section 1.10.1.1 for functional description. See section 2.6.1 for external circuit design-in.
Cellular Auxiliary UART <sup>2</sup>	DCD	8	O	Cellular AUX UART data output	1.8 V output, AUX UART Circuit 104 (RXD) per ITU-T V.24, for AT & data communication and GNSS tunneling. See section 1.10.1.2 for functional description. See section 2.6.1 for external circuit design-in.
	DTR	9	I	Cellular AUX UART data input	1.8 V input, AUX UART Circuit 103 (TXD) per ITU-T V.24, for AT & data communication and GNSS tunneling. Internal active pull-up to V_INT. See section 1.10.1.2 for functional description. See section 2.6.1 for external circuit design-in.
	RI	7	O	Cellular AUX UART clear to send output	1.8 V output, AUX UART Circuit 106 (CTS) per ITU-T V.24. See section 1.10.1.2 for functional description. See section 2.6.1 for external circuit design-in.
	DSR	6	I	Cellular AUX UART ready to send input	1.8 V input, AUX UART Circuit 105 (RTS) per ITU-T V.24. Internal active pull-up to V_INT. See section 1.10.1.2 for functional description. See section 2.6.1 for external circuit design-in.

<sup>2</sup> The support of the auxiliary UART interface is not presented with the “00C” product version of LENA-R8 modules

Function	Pin name	Pin no.	I/O	Description	Remarks
GNSS UART	TXD_GNSS	47	O	GNSS UART data output	LENA-R8001M10 only. GNSS UART data output. See section 1.17.1 for functional description. See section 2.11.1 for external circuit design-in. Internally not connected on LENA-R8001.
	RXD_GNSS	48	I	GNSS UART data input	LENA-R8001M10 only. GNSS UART data input. See section 1.17.1 for functional description. See section 2.11.1 for external circuit design-in. Internally not connected on LENA-R8001.
Cellular USB	VUSB_DET	17	I	Cellular USB detect input	VBUS (5 V typ) must be connected to this pin during the switch-on boot sequence of the module to enable the USB interface, supporting AT / data communication, FOAT, FW update by dedicated tool, diagnostic. Test-Point for diagnostic / FW update very recommended See section 1.10.2 for functional description. See section 2.6.2 for external circuit design-in.
	USB_D-	28	I/O	USB Data Line D-	USB interface supporting AT / data communication, FOAT, GNSS tunneling, FW update by dedicated tool, diagnostic. 90 Ω nominal differential impedance (Z0) 30 Ω nominal common mode impedance (ZCM) Pull-up or pull-down resistors and external series resistors as required by the USB 2.0 specifications [11] are part of the USB pin driver and need not be provided externally. Test-Point for diagnostic / FW update very recommended See section 1.10.2 for functional description. See section 2.6.2 for external circuit design-in.
	USB_D+	29	I/O	USB Data Line D+	USB interface supporting AT / data communication, FOAT, GNSS tunneling, FW update by dedicated tool, diagnostic. 90 Ω nominal differential impedance (Z0) 30 Ω nominal common mode impedance (ZCM) Pull-up or pull-down resistors and external series resistors as required by the USB 2.0 specifications [11] are part of the USB pin driver and need not be provided externally. Test-Point for diagnostic / FW update very recommended See section 1.10.2 for functional description. See section 2.6.2 for external circuit design-in.
	USB_BOOT	33	I	Cellular USB boot	Input to force FW update over cellular USB. Test-Point for FW update very recommended. See section 1.10.2 for functional description. See section 2.6.2 for external circuit design-in.
Cellular I2C <sup>3</sup>	SCL	27	O	Cellular I2C clock	1.8 V open drain, for communication with external u-blox GNSS chips / modules, and other I2C devices. Internal 20 kΩ active pull-up to V_INT. See section 1.10.3 for functional description. See section 2.6.3 for external circuit design-in.
	SDA	26	I/O	Cellular I2C data	1.8 V open drain, for communication with external u-blox GNSS chips / modules, and other I2C devices. Internal 20 kΩ active pull-up to V_INT. See section 1.10.3 for functional description. See section 2.6.3 for external circuit design-in.

<sup>3</sup> The support of the cellular external I2C interface is not presented with the “00C” product version of LENA-R8001M10 modules

Function	Pin name	Pin no.	I/O	Description	Remarks
Cellular Audio <sup>4</sup>	I2S_TXD	35	O	Cellular I2S transmit data	Digital audio data output. See sections 1.11 for functional description. See sections 2.7 for external circuit design-in.
	I2S_RXD	37	I	Cellular I2S receive data	Digital audio data input. See sections 1.11 for functional description. See sections 2.7 for external circuit design-in.
	I2S_CLK	36	I	Cellular I2S bit clock	Digital audio bit clock. See sections 1.11 for functional description. See sections 2.7 for external circuit design-in.
	I2S_WA	34	I	Cellular I2S word alignment	Digital audio word alignment synchronization signal. See sections 1.11 for functional description. See sections 2.7 for external circuit design-in.
Cellular GPIOs	GPIO1	16	I/O	Cellular GPIO	1.8 V GPIO with alternatively configurable functions. See section 1.13 for functional description. See section 2.8 for external circuit design-in.
	GPIO2	23	I/O	Cellular GPIO	1.8 V GPIO with alternatively configurable functions. See section 1.13 for functional description. See section 2.8 for external circuit design-in.
	GPIO3	24	I/O	Cellular GPIO	1.8 V GPIO with alternatively configurable functions. See section 1.13 for functional description. See section 2.8 for external circuit design-in.
	GPIO4	25	I/O	Cellular GPIO	1.8 V GPIO with alternatively configurable functions. See section 1.13 for functional description. See section 2.8 for external circuit design-in.
	GPIO5	42	I/O	Cellular GPIO	1.8 V GPIO with alternatively configurable functions. See section 1.13 for functional description. See section 2.8 for external circuit design-in.
	GPIO6	19	I/O	Cellular GPIO	1.8 V GPIO with alternatively configurable functions. See section 1.13 for functional description. See section 2.8 for external circuit design-in.
GNSS PIOs	TIMEPULSE	45	O	GNSS time pulse	LENA-R8001M10 only. GNSS time pulse output function. See section 1.18 for functional description. See section 2.12 for external circuit design-in. Internally not connected on LENA-R8001.
	EXTINT	46	I	GNSS external interrupt	LENA-R8001M10 only. GNSS external interrupt function. See section 1.18 for functional description. See section 2.12 for external circuit design-in. Internally not connected on LENA-R8001.
Cellular Antenna tuning	RFCTRL1	97	O	Cellular dynamic antenna tuner control output	Function not supported. See section 1.8.3 for functional description. See section 2.4.6 for external circuit design-in.
	RFCTRL2	98	O	Cellular dynamic antenna tuner control output	Function not supported. See section 1.8.3 for functional description. See section 2.4.6 for external circuit design-in.
Reserved	RSVD	21, 49, 62	N/A	RESERVED pin	Pin reserved for possible future use. Internally not connected. See sections 1.14 and 2.9

**Table 3: LENA-R8 series modules pin definition, grouped by function**
<sup>4</sup> The support of the I2S digital audio interface function is not presented with the “00C” product version of LENA-R8 modules

## 1.5 Operating modes

### 1.5.1 Overview

LENA-R8 series modules include 2 variants: the LENA-R8001 modules, integrating a cellular system, and the LENA-R8001M10 modules, integrating the same cellular system of LENA-R8001 modules plus a GNSS system based on the ultra-low-power u-blox M10 GNSS receiver.

As illustrated in [Figure 2](#), the cellular and the GNSS are completely independent subsystems of the LENA-R8001M10 modules, internally interconnected by dedicated I2C interface, with separate supply inputs and separate accessible interfaces for great usage flexibility, as each of the two subsystems can be operated fully independently.

### 1.5.2 Cellular operating modes

The cellular system of LENA-R8 series modules have several operating modes defined in [Table 4](#).

General status	Operating mode	Definition
Power-down	Not-powered mode	VCC supply not present or below operating range: module is switched off.
	Power-off mode	VCC supply within operating range and module is switched off.
Normal Operation	Idle mode	Module processor runs at the minimum frequency to save power consumption.
	Active mode	Module processor runs at normal operating frequency to enable related functions.
	Connected mode	RF Tx/Rx enabled with processor running at related operating frequency.

**Table 4: Module operating modes definition**

The initial operating mode of LENA-R8 series modules cellular system has the **VCC** supply not present or below the operating range: the modules are switched off in not-powered mode.

Once a valid **VCC** supply is applied to LENA-R8 series modules' cellular system, it remains switched off in the power-off mode. Then the proper toggling of the **PWR\_ON** input line is necessary to trigger the switch-on routine of the modules that subsequently enter the active mode.

LENA-R8 series modules cellular system is ready to operate when in active mode. The available communication interfaces are ready, the cellular system can accept and respond to AT commands, entering connected mode upon cellular RF signal reception / transmission.

LENA-R8 series modules cellular system switch from active mode to the low power idle mode whenever possible, if the low power configuration is enabled by the +UPSV AT command. The low power idle mode can last for different time periods according to the specific +UPSV AT command setting, according to the DRX setting, and according to the concurrent activities executed.

LENA-R8 series modules cellular system can be gracefully switched off by the +CPWROFF AT command, or by proper toggling of the **PWR\_ON** input line.

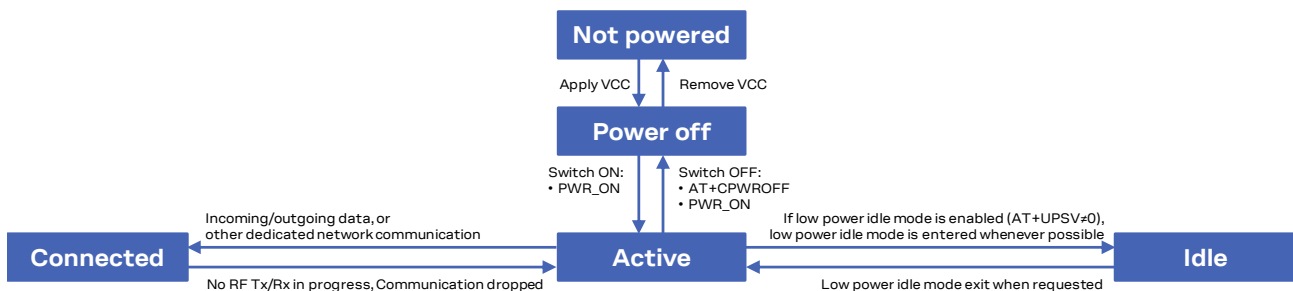

**Figure 3: LENA-R8 series modules operating modes transitions**

### 1.5.3 GNSS operating modes

 LENA-R8001 modules do not include a GNSS receiver: GNSS operating modes are not available.

The GNSS system of LENA-R8001M10 modules, based on u-blox UBX-M10050-KB GNSS receiver, supports different operating modes. These modes represent strategies of controlling the acquisition and tracking engines to optimize performance and power consumption.

#### 1.5.3.1 GNSS continuous mode

The UBX-M10050-KB GNSS receiver uses dedicated signal processing engines optimized for signal acquisition and tracking. The acquisition engine actively searches for and acquires signals during cold starts or when insufficient signals are available during navigation. The tracking engine continuously tracks and downloads all the almanac data and acquires new signals as they become available during navigation. The tracking engine consumes less power than the acquisition engine.

The current consumption is lower when a valid position is obtained quickly after the start of the receiver navigation, the entire almanac has been downloaded, and the ephemeris for each satellite in view is valid. If these conditions are not met, the search for the available satellites takes more time and consumes more power.

 For further details about GNSS continuous mode, see the u-blox UBX-M10050-KB integration manual [\[4\]](#) and the u-blox M10 SPG 5.10 interface description [\[5\]](#).

#### 1.5.3.2 GNSS power save mode

Power Save Mode (PSM) allows a reduction in the GNSS system power consumption by selectively switching parts of the receiver on and off. Power Save Mode (PSM) has two modes of operation:

- Power Save Mode Cyclic Tracking (PSMCT) operation is used when position fixes are required in short periods of 0.5 s to 10 s.
- Power Save Mode On/Off (PSMOO) operation is used for periods longer than 10 s, and can be in the order of minutes, hours, or days.

The mode of operation can be configured, and depending on the setting, the receiver demonstrates different behavior: In on/off operation the receiver switches between phases of startup/navigation and phases with low or almost no system activity (backup/sleep). In cyclic tracking the receiver does not shut down completely between fixes, but uses low-power tracking instead.

 BeiDou B1C is not supported in power save mode.

GPS, GLONASS, BeiDou B1I, Galileo and QZSS signals are supported in power save mode. BeiDou B1C signal is not supported. The receiver is unable to download or process any SBAS data in GNSS power save mode and it is therefore recommended to disable SBAS.

 For further details about GNSS power save mode (operation, acquisition, cyclic tracking, on/off mode, external control, configuration, satellite data download), see the u-blox UBX-M10050-KB integration manual [\[4\]](#) and the u-blox M10 SPG 5.10 interface description [\[5\]](#).

#### 1.5.3.3 GNSS backup mode

A backup mode is an inactive state where the power consumption is reduced to a fraction of that in operating modes. The receiver maintains time information and navigation data to speed up the receiver restart after backup or standby mode.

LENA-R8001M10 GNSS system supports hardware backup mode and software standby mode.

### GNSS hardware backup mode

The hardware backup mode allows entering a backup state and resuming operation by switching the power supplies on and off. The receiver automatically enters the hardware backup mode if the **VCC\_GNSS** is removed. The hardware backup mode always requires an independent backup battery.

**VBCKP\_GNSS** must be supplied to maintain the backup domain (BBR and RTC) to allow better TTFF, accuracy, availability, and power consumption at the next startup. As V\_IO is not supplied, the PIOs cannot be driven by an external host processor. If driving of the PIOs cannot be avoided, buffers are required for isolating the PIOs.



### GNSS software standby mode

Software standby mode allows control over the backup state with the command UBX-RXM-PMREQ. **VCC\_GNSS** must be supplied, however V\_CORE / V\_RF supply is internally disabled. The internal V\_IO supply maintains the BBR, RTC, and PIOs.

Entering the software standby mode clears the RAM memory including the receiver configuration. To maintain the configuration, store it on both RAM and battery-backed RAM (BBR) layers. Configuration in OTP memory is always maintained.

The software standby mode can be set for a specific duration, or until the receiver is woken up by a signal at a wake-up source defined in UBX-RXM-PMREQ. Possible wake-up source is the **EXTINT** pin. See the u-blox M10 SPG 5.10 interface description [5] for more info on UBX-RXM-PMREQ message.

As the internal V\_IO is supplied, the PIOs can be driven by an external host processor. No buffers are required for isolating the PIOs, which reduces cost.

-  The "force" flag must be set in UBX-RXM-PMREQ to enter software standby mode.
-  **VBCKP\_GNSS** should be left open if not used
-  For further details about GNSS backup mode, see the UBX-M10050-KB integration manual [4] and the u-blox M10 SPG 5.10 interface description [5].

### 1.5.3.4 Internal GNSS control via modem

u-blox has implemented special features to ease the design effort required for the integration of the LENA-R8001M10 module in a host application.

The GNSS system integrated in the LENA-R8001M10 module can be operated fully independently from the cellular system integrated in the same module, but, as shown in [Figure 2](#), the two systems are internally interconnected by dedicated I2C interface, allowing access to the GNSS system directly via the cellular system, which relays control messages to the GNSS system.

The use of the additional UART interface connected to GNSS system integrated in LENA-R8001M10 is not strictly necessary: AT commands and/or the GNSS data tunneling mode via the USB interface of the cellular system of LENA-R8001M10 allow control of the GNSS system integrated in the module from an external host processor.

Implementing the internal GNSS control via modem with the LENA-R8001M10 modules as briefly illustrated in [Figure 4](#), or with more details in [Figure 62](#), the GNSS system can be operated only if the cellular system is operating.

The GNSS system integrated in the LENA-R8001M10 module can be powered using the **V\_INT** 1.8 V supply output of the cellular system, generated by an internal linear LDO regulator.

The GNSS system can be switched on/off using the **GPIO2** pin of the cellular system configured with the "GNSS supply enable" function.

The GNSS system can wake up the cellular system from the low power idle mode when it is ready to send GNSS data using the dedicated internal line configured with “GNSS Tx data ready” function.

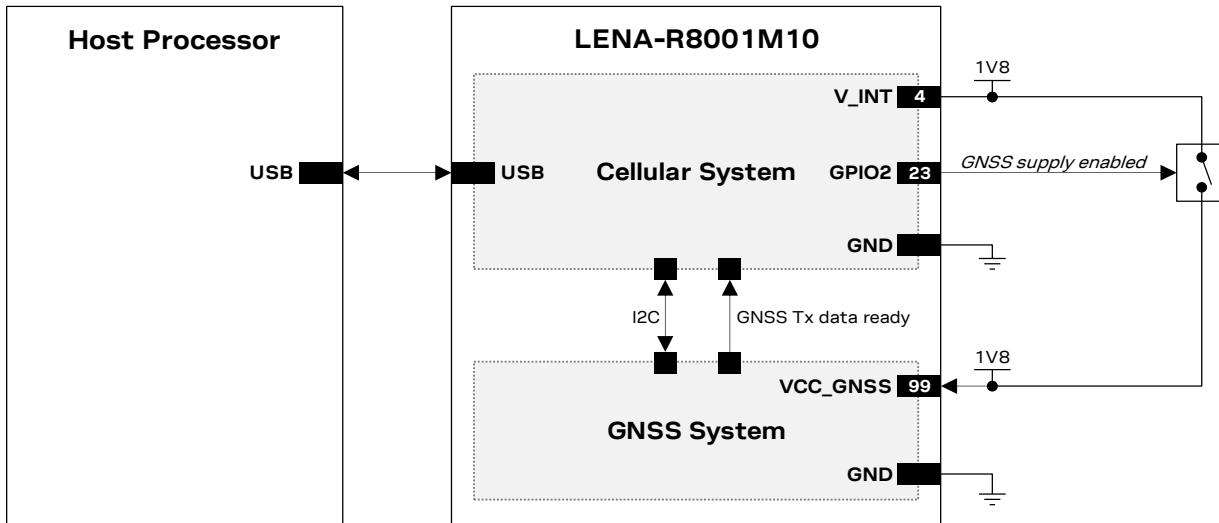

Figure 4: LENA-R8001M10 internal GNSS control via modem block diagram

The LENA-R8001M10 modules feature embedded GNSS aiding, that is a set of specific features developed by u-blox to enhance GNSS performance, decreasing the Time-To-First-Fix (TTFF), thus allowing the calculation of the position in a shorter time with higher accuracy:

- Local aiding
- AssistNow Online
- AssistNow Offline
- AssistNow Autonomous

## 1.6 Cellular power management

### 1.6.1 Cellular supply input (VCC)

The cellular system of the LENA-R8 series modules must be supplied via the three **VCC** pins that represent the cellular system power supply input.

The **VCC** pins are internally connected to the RF power amplifier and to the integrated Power Management Unit: all supply voltages needed by the module are generated from the **VCC** supply by integrated voltage regulators, including the **V\_INT** supply for generic digital interfaces (as the UARTs, I2C, I2S, GPIOs) and the **VSIM** supply for the SIM interface.

During operation, the current drawn by the LENA-R8 series modules through the **VCC** pins can vary by several orders of magnitude. This ranges from the pulse of current consumption during GSM transmitting bursts at maximum power level in connected mode (as described in section 1.6.1.2) to the low current consumption during the low power idle mode (as described in section 1.6.1.4).

LENA-R8 series modules provide separate supply inputs over the three **VCC** pins:

- **VCC** pins #52 and #53 represent the supply input for the internal RF power amplifier, demanding most of the total current drawn when RF transmission is enabled during a voice/data call
- **VCC** pin #51 represents the supply input for the internal baseband Power Management Unit and the internal transceiver, demanding minor part of the total current drawn

Figure 5 provides a simplified block diagram of LENA-R8 series modules internal VCC supply routing.

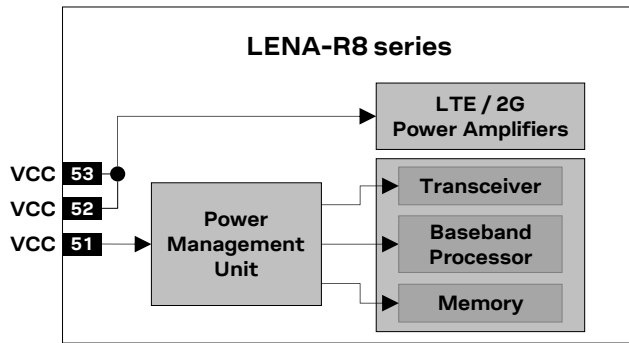

Figure 5: LENA-R8 series modules internal VCC supply routing simplified block diagram

### 1.6.1.1 VCC supply requirements

Table 5 summarizes the requirements for the VCC module supply. See section 2.2.1 for all the suggestions to properly design a VCC supply circuit compliant to the requirements listed in Table 5.

**⚠ VCC supply circuit affects the RF compliance of the device integrating LENA-R8 series modules with applicable required certification schemes as well as antenna circuit design. RF performance is optimized by fulfilling the requirements for the VCC supply summarized in Table 5.**

Item	Requirement	Remark
VCC nominal voltage	Within VCC normal operating range: 3.4 V min. / 4.2 V max.	Operating within 3GPP / ETSI specifications: RF performance is optimized when VCC PA voltage is inside the normal operating range limits.
VCC voltage during normal operation	Within VCC extended operating range: 3.2 V min. / 4.5 V max.	Operating with possible slight deviation in RF performance outside normal operating range. <b>VCC</b> voltage must be above the extended operating range minimum limit to switch-on the module and to avoid possible switch-off of the module. Operation above VCC extended operating range is not recommended and may affect device reliability.
VCC average current	Support with adequate margin the highest averaged VCC current consumption value in connected mode conditions specified in the LENA-R8 series data sheet [1]	The highest averaged VCC current consumption can be greater than the specified value according to the actual antenna mismatching, temperature and VCC voltage. For a safe design margin, use a VCC supply source that can deliver double the typical average VCC current consumption at maximum Tx power, normal ambient temperature and normal voltage condition shown in the LENA-R8 series data sheet [1]. See 1.6.1.2 / 1.6.1.2 for connected mode current profiles.
VCC peak current	Support with margin the highest peak VCC current consumption value in connected mode conditions specified in the LENA-R8 series data sheet [1]	The specified highest peak of VCC current consumption occurs during GSM single transmit slot in 850/900 MHz connected mode, in case of a mismatched antenna. See 1.6.1.2 for 2G connected mode current profiles.
VCC voltage drop during 2G Tx slots	Lower than 400 mV	VCC voltage drop directly affects the RF compliance with applicable certification schemes. Figure 7 describes VCC voltage drop during Tx slots.
VCC voltage ripple during 2G/LTE Tx	Noise in the supply must be minimized	VCC voltage ripple directly affects the RF compliance with applicable certification schemes. Figure 7 describes VCC voltage ripple during Tx slots.
VCC under/over-shoot at start/end of Tx slots	Absent or at least minimized	VCC under/over-shoot directly affects the RF compliance with applicable certification schemes. Figure 7 describes VCC voltage under/over-shoot.

Table 5: Summary of VCC supply requirements

### 1.6.1.2 VCC consumption in 2G connected mode

When a GSM call is established, the **VCC** consumption is determined by the current consumption profile typical of the GSM transmitting and receiving bursts.

The current consumption peak during a transmission slot is strictly dependent on the transmitted power, which is regulated by the network. The transmitted power in the transmit slot is also the more relevant factor for determining the average current consumption.

If the module is transmitting in 2G single-slot mode (as in GSM talk mode) in the 850 or 900 MHz bands, at the maximum RF power control level (approximately 2 W or 33 dBm in the Tx slot/burst), the current consumption can reach a high peak / pulse (see LENA-R8 series data sheet [1]) for 576.9  $\mu$ s (width of the transmit slot/burst) with a periodicity of 4.615 ms (width of 1 frame = 8 slots/burst), so with a 1/8 duty cycle according to GSM TDMA (Time Division Multiple Access).

If the module is transmitting in 2G single-slot mode in the 1800 or 1900 MHz bands, the current consumption figures are quite lower than the one in the low bands, due to the 3GPP specifications.

Figure 6 shows an example of the module current consumption profile versus time in GSM talk mode.

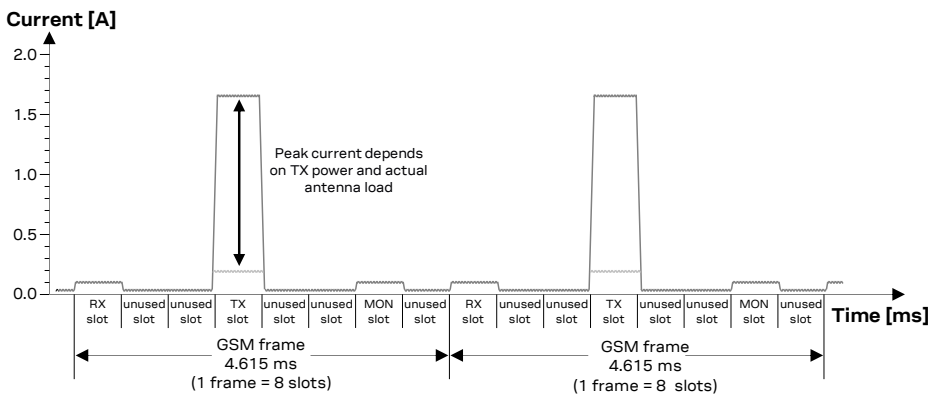

Figure 6: VCC current consumption profile versus time during a GSM call (1 TX slot, 1 RX slot)

Figure 7 illustrates **VCC** voltage profile versus time during a GSM call, according to the related **VCC** current consumption profile described in Figure 6.

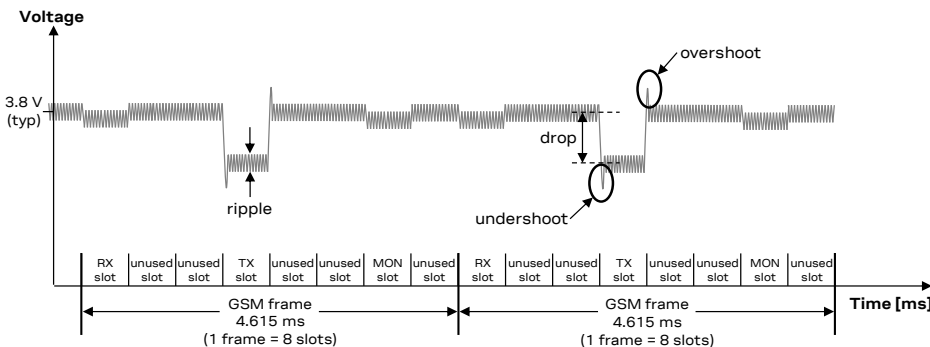

Figure 7: Description of the VCC voltage profile versus time during a GSM call (1 TX slot, 1 RX slot)

### 1.6.1.3 VCC consumption in LTE connected mode

During an LTE connection, the module may transmit and receive continuously due to the frequency division duplex (FDD) mode of operation or it may transmit and receive alternatively due to the time division duplex (TDD) mode of operation available with LTE radio access technology.

The current consumption depends on output RF power, which is always regulated by the network (the current base station), sending power control commands to the module, indicating a maximum output RF power of approximately 0.25 W down to a minimum output RF power of approximately 0.1  $\mu$ W, so that the current consumption may vary a lot as illustrated in Figure 8, showing an example of current

consumption profile versus time in the LTE FDD connected mode. Detailed current consumption values can be found in LENA-R8 series data sheet [1].

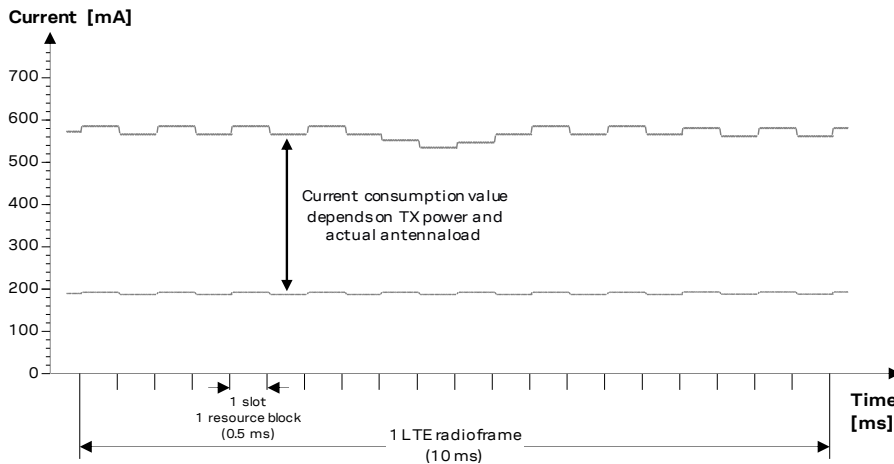

Figure 8: VCC current consumption profile versus time during LTE connection (TX and RX continuously enabled)

#### 1.6.1.4 VCC consumption in low power idle mode

The power saving configuration is disabled by default, but it can be enabled using the appropriate AT command (see the AT commands manual [2], +UPSV AT command). When power saving is enabled, the module automatically enters low power idle mode whenever possible, reducing consumption.

When the power saving configuration is enabled and the module is registered or attached to a network, the module automatically enters the low power idle mode whenever possible, but it must periodically monitor the paging channel of the current base station (paging block reception), in accordance to 2G / LTE requirements, waking up periodically to receive the paging block. In between, the module enters low power idle mode whenever possible. This is known as discontinuous reception (DRX). Figure 9 illustrates a typical example of the current consumption profile in this condition, the module is in low-power idle mode and periodically wakes up to active mode to monitor the paging channel for paging block reception. Detailed consumption values can be found in LENA-R8 series data sheet [1].

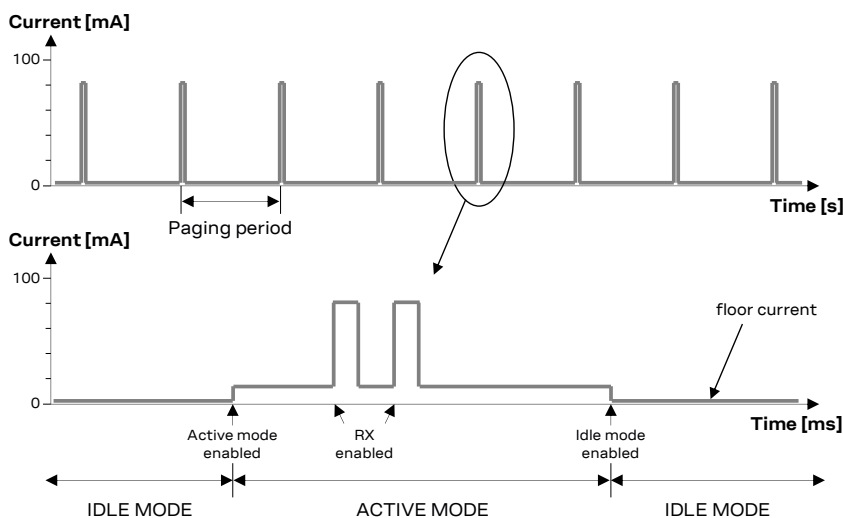

Figure 9: VCC current consumption profile with power saving enabled and module registered with the network

### 1.6.1.5 VCC consumption in active mode (low power idle mode disabled)

The active mode is the state where the module is switched on and ready to communicate with an external device by the application interfaces (as the USB or the UART serial interface). The module processor core is active, and the 26 MHz reference clock frequency is used.

If the low power idle mode configuration is disabled, as it is by default (see AT commands manual [2], +UPSV AT commands for details), the module remains in active mode. Figure 10 illustrates a typical example of the module current consumption profile in this condition. In such case, the module is registered with the network and while active mode is maintained, the receiver is periodically activated to monitor the paging channel for paging block reception. Detailed current consumption values can be found in the LENA-R8 series data sheet [1].

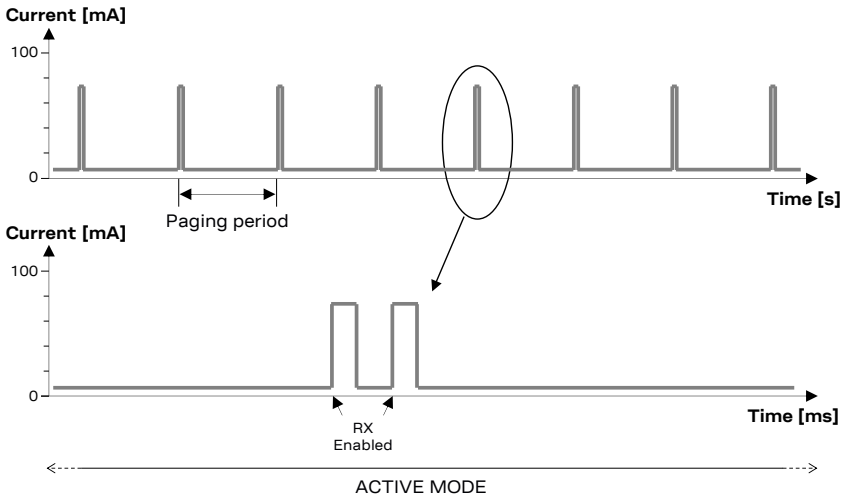

Figure 10: VCC current consumption profile with power saving disabled and module registered with the network

### 1.6.2 Cellular RTC supply input / output (V\_BCKP)

When **VCC** voltage is within the valid operating range, the internal Power Management Unit (PMU) supplies the Real Time Clock (RTC) of the LENA-R8 series modules' cellular subsystem, and the same supply voltage is available on the **V\_BCKP** pin. If the **VCC** voltage is under the minimum operating limit (as in not powered mode), the **V\_BCKP** pin can externally supply the RTC of the cellular subsystem.

### 1.6.3 Cellular generic digital interfaces supply output (V\_INT)

The **V\_INT** output pin of the LENA-R8 series modules cellular system is connected to an internal 1.8 V supply with a current capability specified in the LENA-R8 series data sheet [1]. This supply is internally generated by a linear LDO regulator integrated in the Power Management Unit and it is internally used to source the generic digital interfaces of the cellular module (as the UARTs, I2C, I2S, GPIOs), as described in Figure 11. The output of this regulator is enabled when the cellular system is switched on, and disabled when the cellular system is switched off.

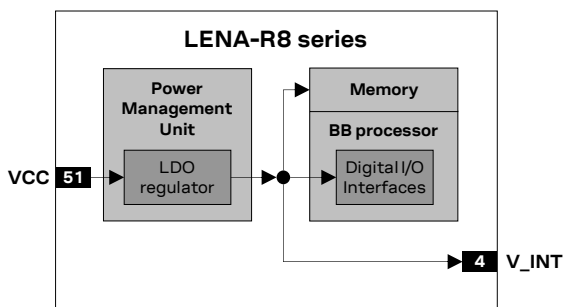

Figure 11: LENA-R8 series interfaces supply output (V\_INT) simplified block diagram

## 1.7 Cellular system function interfaces

### 1.7.1 Cellular system power-on

When LENA-R8 series modules cellular system is not powered, it can be switched on as follows:

- Apply a voltage at the **VCC** cellular system supply input within the operating range (see LENA-R8 series data sheet [1], **VCC** operating input voltage), then wait at least 1.5 s, and then force a low level at the **PWR\_ON** input, which is normally set high by an internal pull-up, for a valid time period (see LENA-R8 series data sheet [1], **PWR\_ON** low time to trigger cellular system switch on).

When LENA-R8 series modules cellular system is in power-off mode (switched off, with a voltage at the **VCC** supply input within the normal operating range reported in LENA-R8 series data sheet [1]), it can be switched on by:

- Forcing a low level at the **PWR\_ON** input pin, which is normally set high by an internal pull-up, for a valid time period (see the LENA-R8 series data sheet [1], **PWR\_ON** low time for switch on).
- RTC alarm, i.e. pre-programmed scheduled time by +CALA AT command.

The **PWR\_ON** input line is intended to be driven by open drain, open collector, or contact switch.

As described in Figure 12, the **PWR\_ON** input line is internally pulled up. The input voltage thresholds are different from the other generic digital interfaces as indicated in LENA-R8 series data sheet [1].

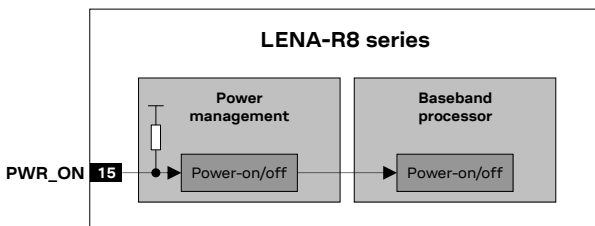

Figure 12: LENA-R8 series PWR\_ON input description

Figure 13 shows the module switch-on sequence from the not-powered mode, with following phases:

- The external power supply is applied to the **VCC** module cellular system pins
- The **PWR\_ON** and the **RESET\_N** lines immediately rise to high logic level due to internal pull-ups.
- After at least 1.5 s, the **PWR\_ON** input line is held low for a valid time, triggering cellular system switch-on sequence.
- All the generic digital pins are tri-stated until the switch-on of their supply source (**V\_INT**).
- The internal reset signal is held low: the baseband core and all digital pins are held in reset state. When the internal reset signal is released, any digital pin is set in the correct sequence from the reset state to the default operational configured state. The duration of this phase differs between generic digital interfaces and USB interface due to host / device enumeration timings.
- The module cellular system is ready to operate after all interfaces are configured.

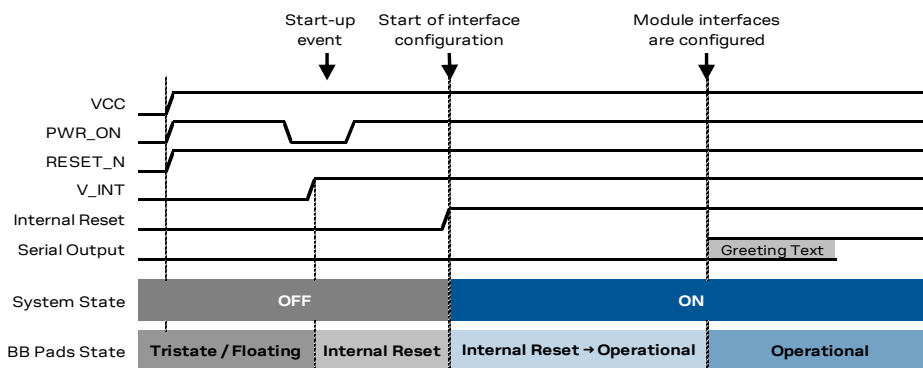









Figure 13: LENA-R8 series switch-on sequence description

-  The Internal Reset signal is not available on a module pin, but it is highly recommended to monitor:
  - the **V\_INT** pin, to detect the start of the LENA-R8 series cellular system switch-on sequence
  - the greeting text configured on the serial interface (see AT commands manual [2], +CSGT AT command), to signal that the cellular system is ready to operate
-  Before the switch-on of the generic digital interface supply (**V\_INT**) of the module, no voltage driven by an external application should be applied to any generic digital interface of the module.
-  Before the LENA-R8 series cellular system is ready to operate, the host application processor should not send any AT command over AT communication interfaces (USB, UART) of the module.
-  The duration of the LENA-R8 series cellular system switch-on routine can largely vary depending on the application / network settings and the current module activities.
-  It is highly recommended to avoid an abrupt removal of the **VCC** supply during the boot sequence of the modules' cellular system.

## 1.7.2 Cellular system power-off

LENA-R8 series modules cellular system can be gracefully switched off, with storage of the current parameter settings in the module's internal non-volatile memory and a clean network detach, in one of these ways:

- AT+CPWROFF command (see the u-blox AT commands manual [2]).
- Force a low pulse at the **PWR\_ON** input pin, which is normally set high by an internal pull-up, for a valid time period (see LENA-R8 series data sheet [1], **PWR\_ON** low time for graceful switch off).
-  The graceful switch-off procedure triggered by AT+CPWROFF command or by a low pulse at the **PWR\_ON** input is the recommended method to switch off LENA-R8 series cellular system.
-  The gracefully switch-off procedure must be started as indicated above, and then a proper **VCC** supply must be held at least until the end of the cellular system internal switch-off sequence, which occurs when the generic digital interfaces supply output (**V\_INT**) is switched off.

An abrupt shutdown occurs on the cellular system, without storage of the current parameter settings and without a clean network detach, when the **VCC** supply drops below the extended operating range.

-  It is highly recommended to avoid an abrupt **VCC** power removal during cellular system normal operations. It is highly recommended to start the graceful switch-off procedure as indicated above, and then held a proper **VCC** supply voltage at least until the end of the modules' internal switch-off sequence, which occurs when the **V\_INT** supply output is switched off by the module.

An over-temperature or an under-temperature shutdown occurs on LENA-R8 series modules cellular system when the temperature measured within the cellular module reaches the dangerous area, if the optional Smart Temperature Supervisor feature is enabled and configured by +USTS AT command. See the LENA-R8 series data sheet [1] for the internal temperature thresholds defined for the Smart Temperature Supervisor feature, and see the AT commands manual [2] for the +USTS AT command description.

Figure 14 and Figure 15 describe the LENA-R8 series modules cellular system switch-off sequence started by AT+CPWROFF command and by **PWR\_ON** input pin, allowing storage of current parameter settings in the module's non-volatile memory and a clean network detach, with the following phases:

- When the +CPWROFF AT command is sent, or when a low pulse with appropriate time duration is applied at the **PWR\_ON** input pin, the module starts the switch-off routine.
- Then, if the +CPWROFF AT command has been sent, the module returns "OK" on the AT interface: the switch-off routine is in progress.
- At the end of the switch-off routine, all the digital pins are tri-stated and all the internal voltage regulators are turned off, including the generic digital interfaces supply (**V\_INT**).
- Then, the module remains in switch-off mode as long as a switch-on event does not occur (applying a low level to **PWR\_ON** input pin), and it enters not-powered mode if the **VCC** supply is removed.

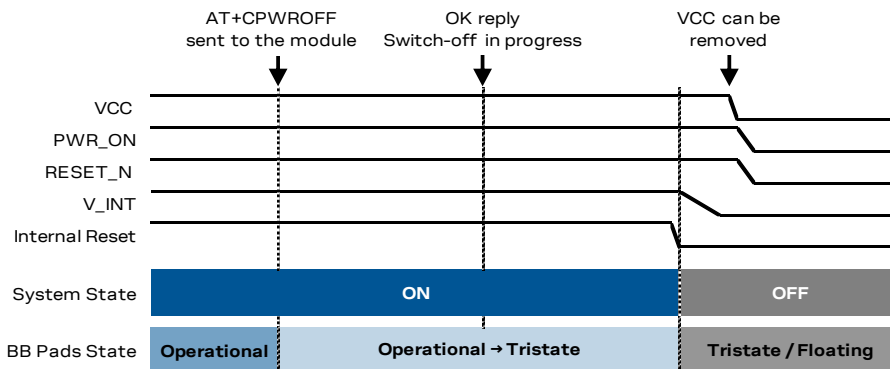

Figure 14: LENA-R8 series modules switch-off sequence by AT+CPWROFF command

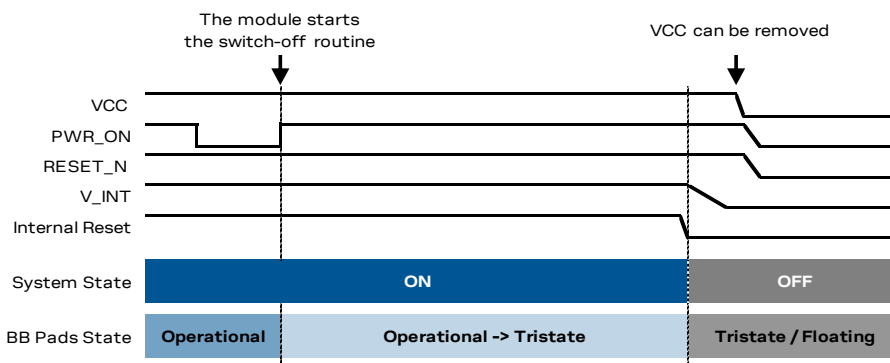

Figure 15: LENA-R8 series modules switch-off sequence by PWR\_ON pin

- 🔑 The Internal Reset signal is not available on a module pin, but it is highly recommended to monitor:
  - the **V\_INT** pin, or
  - the UART break condition,
 to detect the end of the LENA-R8 series module cellular system switch-off sequence
- 🔑 It is highly recommended to avoid an abrupt removal of the **VCC** supply before the end of the cellular system switch-off sequence, which occurs when the **V\_INT** supply output is switched off.
- 🔑 The duration of each phase in the LENA-R8 series cellular system switch-off routines can largely vary depending on the application / network settings and the concurrent module activities.

### 1.7.3 Cellular system reset

LENA-R8 series modules cellular system can be gracefully reset (rebooted) by:

- AT+CFUN=16 command (see the u-blox AT commands manual [2] for detailed description and other possible options).

This event causes an “internal” or “software” reset of the module, including the power management unit. The current parameter settings are saved in the module’s non-volatile memory and a proper network detach is performed: this is the correct way to reset the modules.

An abrupt hardware reset occurs on LENA-R8 series modules’ cellular system, without storage of the current parameter settings and without a clean network detach, when:

- Forcing a low level at the **RESET\_N** input pin, which is normally set high by an internal pull-up, for a valid time period (see the LENA-R8 series data sheet [1], **RESET\_N** input line low time to trigger cellular system abrupt reset / reboot).

The **RESET\_N** line is intended to be driven by open drain, open collector or contact switch.

 It is highly recommended to avoid an abrupt hardware reset of the module by forcing a low level on the **RESET\_N** input (see LENA-R8 series data sheet [1], **RESET\_N** low time to trigger cellular system reset) during cellular system normal operation: the **RESET\_N** line should be set low only if reset via AT commands fails, or if the module does not provide a reply to a specific AT command after a time period longer than the one defined in the AT commands manual [2].

The **RESET\_N** input line is intended to be driven by open drain, open collector, or contact switch.

As described in Figure 16, the **RESET\_N** input line is internally pulled up. The input voltage thresholds are different from the other generic digital interfaces. Detailed electrical characteristics are described in the LENA-R8 series data sheet [1].

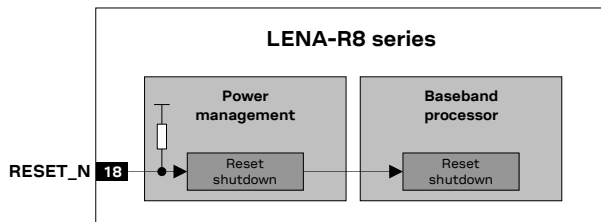

Figure 16: LENA-R8 series **RESET\_N** input equivalent circuit description

## 1.8 Cellular antenna interface

### 1.8.1 Cellular antenna RF interface (ANT)

LENA-R8 series modules provide one cellular RF interfaces for connecting the external antenna:

- The **ANT** port is the RF input/output for transmission and reception of LTE/2G RF signals. The **ANT** port has a 50  $\Omega$  nominal characteristic impedance and must be connected to the cellular Tx / Rx antenna through a 50  $\Omega$  transmission line to allow proper RF transmission / reception.

### 1.8.1.1 Cellular antenna RF interface requirements

Table 6 summarizes the requirements for the RF interface (**ANT**). See section 2.4.2 for suggestions to properly design the circuits compliant with these requirements.

 The antenna circuits affect the RF compliance of the host end-device integrating the LENA-R8 series modules with applicable required certification schemes (for further details see section 4). RF performance is optimized by fulfilling the requirements summarized in Table 6.

Item	Requirement	Remark
<b>Impedance</b>	50 $\Omega$ nominal characteristic impedance	The impedance of the antenna RF connection must match the 50 $\Omega$ impedance of the <b>ANT</b> port.
<b>Frequency Range</b>	See the LENA-R8 series data sheet [1]	The required frequency range of the antenna connected to the <b>ANT</b> port depends on the operating bands of the used cellular module and the used mobile network.
<b>Return Loss</b>	S11 < -10 dB (VSWR < 2:1) recommended S11 < -6 dB (VSWR < 3:1) acceptable	The Return loss or the S11, as the VSWR, refers to the amount of reflected power, measuring how well the antenna RF connection matches the 50 $\Omega$ characteristic impedance of the <b>ANT</b> port. The impedance of the antenna termination must match as much as possible the 50 $\Omega$ nominal impedance of the <b>ANT</b> port over the operating frequency range, reducing as much as possible the reflected power.
<b>Efficiency</b>	> -1.5 dB (> 70%) recommended > -3.0 dB (> 50%) acceptable	The radiation efficiency is the ratio of the radiated power to the power delivered to the antenna input: the efficiency is a measure of how well an antenna receives or transmits. The radiation efficiency of the antenna connected to the <b>ANT</b> port needs to be high enough over the operating frequency range to comply with the Over-The-Air (OTA) radiated performance requirements, as the Total Radiated Power (TRP) and the Total Isotropic Sensitivity (TIS), specified by the applicable related certification schemes.
<b>Maximum Gain</b>	According to radiation exposure limits	The power gain of an antenna is the radiation efficiency multiplied by the directivity: the gain describes how much power is transmitted in the direction of peak radiation to that of an isotropic source. The maximum gain of the antenna connected to the <b>ANT</b> port must not exceed the herein stated value to comply with regulatory agencies radiation exposure limits. For additional info, see sections 4.2.2, 4.3.1 and/or 4.4.
<b>Input Power</b>	> 33 dBm (> 2.0 W)	The antenna connected to the <b>ANT</b> port must support the maximum power transmitted by the modules with an adequate margin.

Table 6: Summary of primary Tx/Rx antenna RF interface (**ANT1**) requirements

### 1.8.2 Cellular antenna detection (ANT\_DET)

The antenna detection is based on ADC measurement. The **ANT\_DET** pin is an analog to digital converter (ADC) provided to sense the antenna presence.

The antenna detection function provided by the **ANT\_DET** pin is an optional feature that can be implemented if the application requires it. The antenna detection is forced by the +UANTR AT command. See the u-blox AT commands manual [2] for more details on this feature.

The **ANT\_DET** pin generates a DC current (for detailed characteristics, see the LENA-R8 series data sheet [1]) and measures the resulting DC voltage, thus determining the resistance from the antenna connector provided on the application board to GND. The requirements to achieve antenna detection functionality areas follows:

- an RF antenna assembly with a built-in resistor (diagnostic circuit) must be used
- an antenna detection circuit must be implemented on the application board

See section 2.4.5 for the antenna detection circuit on the application board and the diagnostic circuit on the antenna assembly design-in guidelines.

### 1.8.3 Cellular antenna dynamic tuning interface (RFCTRL1 / RFCTRL2)

 The cellular antenna dynamic tuner interface over **RFCTRL1 / RFCTRL2** pins is not supported.

LENA-R8 series modules' cellular system includes 2 output pins (**RFCTRL1 / RFCTRL2**) for real time control of an external antenna tuning IC according to the actual cellular band used by the module.

These pins, paired with an external antenna tuner IC or RF switch, can be used to:

- tune antenna impedance to reduce power losses due to mismatch
- tune antenna aperture to improve total antenna efficiency
- select the optimal antenna for each operating band

## 1.9 Cellular SIM interface

### 1.9.1 Cellular SIM card / chip interface

LENA-R8 series modules provide a high-speed SIM/ME interface, including automatic detection and configuration of the voltage required by the connected SIM card or chip.

Both 1.8 V and 3 V SIM types are supported: activation and deactivation with an automatic voltage switch from 1.8 V to 3 V is implemented, according to the ISO-IEC 7816-3 specifications.

The **VSIM** supply output pin provides internal short circuit protection to limit the start-up current and protect the device in short circuit situations.

## 1.10 Cellular serial communication interfaces

LENA-R8 series modules provide the following serial communication interfaces:

- Main UART: serial interface available for the communication with a host application processor (AT and data communication, multiplexer functionality, and FW update by means of FOAT). See section [1.10.1.1](#).
- Auxiliary UART<sup>5</sup>: serial interface available for communication with a host application processor (AT and data communication, and GNSS tunneling). See section [1.10.1.2](#).
- USB: USB 2.0 compliant interface available for the communication with a host application processor (AT and data communication, GNSS tunneling, FW update by the FOAT, FW update by dedicated tool, and diagnostics). See section [1.10.2](#).
- I2C interface<sup>6</sup>: I2C-bus compliant interface available for the communication with compatible external u-blox M10 GNSS chips or modules. See section [1.10.3](#).

### 1.10.1 Cellular UART interfaces

#### 1.10.1.1 Cellular main UART interface

LENA-R8 series cellular system includes a main primary UART serial interface for communication with an application host processor, supporting:

- AT / data communication
- Multiplexer protocol functionality (see [1.10.1.3](#))
- FW upgrades by means of the FOAT feature

<sup>5</sup> The support of the auxiliary UART interface is not presented with the "00C" product version of LENA-R8 modules

<sup>6</sup> The support of the cellular external I2C interface is not presented with the "00C" product version of LENA-R8001M10 modules

The UART interface provides RS-232 functionality conforming to ITU-T V.24 recommendation [7], with CMOS compatible signal levels: 0 V for low data bit or ON state, and 1.8 V for high data bit or OFF state (for detailed electrical characteristics, see the LENA-R8 series data sheet [1]), providing:

- data lines (**RXD** as output, **TXD** as input),
- hardware flow control lines (**CTS** as output, **RTS** as input),
- modem status and control lines (**DTR** as input, **DSR** as output, **DCD** as output, **RI** as output).

The module is designed to operate as cellular modem, as data circuit-terminating equipment (DCE) according to the ITU-T V.24 recommendation [7]. A host application processor connected to the module through the UART interface represents the data terminal equipment (DTE).

UART signal names of the modules conform to the ITU-T V.24 [7]: e.g., **TXD** line represents data transmitted by the DTE (host processor output) and received by the DCE (module input).

The UART interface is configured by default in AT command mode: the module waits for AT command instructions and interprets all the characters received as commands to execute.

All supported functionalities can be configured by the AT commands documented in the AT commands manual [2].

Hardware flow control is enabled by default, and it can be enabled/disabled by AT commands (see the AT commands manual [2], &K, +IFC AT commands).

One-shot autobauding is supported and is enabled by default: automatic baud rate detection is performed only once, at module start up. When autobauding is enabled, the first AT command sent to the module is not processed, because it is used by the module to detect the baud rate. After the detection, the module works at the detected baud rate which can only be changed via the +IPR AT command. For more details, see the AT commands manual [2].

115'200 bit/s, 230'400 bit/s, 460'800 bit/s, 921'600 bit/s baud rates are supported.

The 8N1 (8 data bits, no parity, 1 stop bit) frame format configuration is enabled by default (illustrated in Figure 17), and other frame formats can be set by appropriate AT command (see the AT commands manual [2], +ICF AT command). The 8N1, 8N2 and 8E1 frame formats are supported.

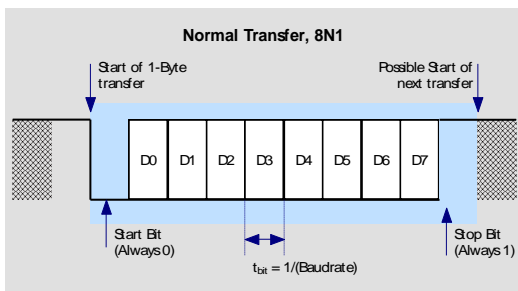



Figure 17: Description of the UART 8N1 frame format (8 data bits, no parity, 1 stop bit)

The **DSR** and **DCD** pins toggle as output for ~600 ms during the boot of the module cellular system. The **DSR** and **DCD** pins are also set as output during the firmware update over the USB interface.

### 1.10.1.2 Cellular auxiliary UART interface

 The support of the cellular auxiliary UART interface is not presented with the “00C” product version of LENA-R8 series modules

LENA-R8 series cellular system includes an auxiliary UART serial interface (AUX UART) for communication with a host processor:

- AT / data communication
- GNSS data tunneling

The AUX UART interface provides RS-232 functionality conforming to ITU-T V.24 [7], with CMOS compatible signal levels: 0 V for low data bit or ON state, and 1.8 V for high data bit or OFF state (for detailed electrical characteristics, see the LENA-R8 series data sheet [1]), providing:

- data lines (**DCD** as data output, **DTR** as data input),
- hardware flow control lines (**RI** as flow control output, **DSR** as flow control input).

### 1.10.1.3 Multiplexer protocol

LENA-R8 series modules include multiplexer functionality on the main UART physical interface as per 3GPP TS 27.010 [10]. The multiplexer functionality is not supported on the auxiliary UART interface.

The multiplexer functionality is a data link protocol which uses HDLC-like framing and operates between the module (DCE) and the application processor (DTE), allowing several simultaneous sessions over the physical link (main primary UART): the user can concurrently use AT interface on one MUX channel and data communication on another MUX channel.

## 1.10.2 Cellular USB interface

LENA-R8 series modules include a High-Speed USB 2.0 interface with a 480 Mbit/s maximum data rate, representing the main interface for transferring high speed data with a host application processor, supporting:

- AT / data communication
- Ethernet-over-USB
- GNSS data tunneling
- FW upgrades by the FOAT feature
- FW upgrades by dedicated tool running on host PC
- Trace log capture for diagnostic purposes

The module acts as a USB device and can be connected to a USB host such as a Personal Computer or an embedded application microprocessor equipped with compatible drivers.

The **USB\_D+/USB\_D-** lines carry USB serial bus data and signaling according to the Universal Serial Bus Revision 2.0 specification [11]. The USB interface is enabled if an external valid USB VBUS voltage applied on the **VUSB\_DET** input pin of the module.

The RS-232 / ITU-T V.24 functionality over virtual logical lines is not supported over the USB interface.

The USB interface is controlled by the AT commands documented in the AT commands manual [2].

The USB interface of LENA-R8 series cellular system provides the following USB functions:

- Virtual serial ports over USB for AT commands and data communication
- Virtual serial port over USB for GNSS data tunneling
- Virtual serial ports over USB for Diagnostic logs
- RNDIS for Ethernet-over-USB
- CDC-ECM for Ethernet-over-USB

LENA-R8 series cellular system has the following VID (Vendor ID) and PID (Product ID) as USB device in the default factory-programmed normal operating mode:

- VID = 0x1782
- PID = 0x4D10

The following vendor-specific virtual serial ports are enumerated

- USB serial port 0: AT commands and data communication
- USB serial port 1: Reserved
- USB serial port 2: Reserved
- USB serial port 3: Diagnostic log (CP)
- USB serial port 4: Diagnostic log (AP)
- USB serial port 5: GNSS data tunneling
- USB serial port 6: AT commands and data communication
- USB serial port 7: AT commands and data communication

The default factory-programmed configuration of the USB interface can be changed by dedicated AT command to include the RNDIS or the CDC-ECM function for Ethernet-over-USB capability in addition to the vendor-specific 8 virtual serial ports listed above, with change in the USB PID as following:

- PID = 0x4D11 with 8 virtual serial ports + RNDIS configuration
- PID = 0x4D13 with 8 virtual serial ports + CDC-ECM configuration

The USB interface is compatible with standard Linux/Android USB kernel drivers. The capability and configuration of the USB interface can be reported by running “lsusb -v” or an equivalent command available in the host operating system when the USB of the cellular system is connected.

 The **USB\_BOOT** input pin must be set high, at the 1.8 V voltage level of the **V\_INT** supply output, to enable the FW update by the dedicated tool over the USB interface of the LENA-R8 series modules’ cellular system. Only if the **USB\_BOOT** pin is left floating (unconnected), or it is set low (grounded), LENA-R8 series modules’ cellular system can boot in normal operating mode.

LENA-R8 series cellular system has the following VID (Vendor ID) and PID (Product ID) as USB device, if the FW download mode over USB is set (**USB\_BOOT** input pin set high, at the 1.8 V voltage level of the **V\_INT** supply output):

- VID = 0x0525
- PID = 0xA4A7

 It is highly recommended to provide access to the **VUSB\_DET**, **USB\_D+**, **USB\_D-** and **USB\_BOOT** pins of LENA-R8 series modules’ cellular system for FW update and for diagnostic purpose, by test points directly connected to the pins.

### 1.10.3 Cellular I2C interface

 The support of the cellular I2C interface over **SDA** and **SCL** pins is not presented with the “00C” product version of the LENA-R8001M10 modules.

LENA-R8001 modules include an I2C-bus compatible interface over the **SDA** and **SCL** pins available to communicate with external u-blox M10 GNSS chips / modules.

The AT command interface is not available on the I2C interface. The I2C device-mode operation is not supported: the LENA-R8 series module can act as the I2C host that can communicate with compatible external I2C devices in accordance with the I2C bus specifications [12].

u-blox has implemented special features to ease the design effort required for the integration of a LENA-R8001 cellular module with an external u-blox M10 GNSS receiver.

Combining the LENA-R8001 cellular module with an external u-blox M10 GNSS receiver allows designers to have access to the positioning receiver directly via the cellular module: it relays control messages to the GNSS receiver via a dedicated I2C interface. A second interface connected to the positioning receiver is not necessary: AT commands and/or the GNSS data tunneling mode via USB interface of the cellular module allow control of the GNSS receiver from any host processor.

The modules feature embedded GNSS aiding, that is, a set of specific features developed by u-blox to enhance GNSS performance, decreasing the Time-To-First-Fix (TTFF), thus allowing the calculation of the position in a shorter time with higher accuracy:

- Local aiding
- AssistNow Online
- AssistNow Offline
- AssistNow Autonomous

The embedded GNSS aiding features can be used only if the I2C interface of the LENA-R8001 cellular module is connected to the u-blox GNSS receivers.

The LENA-R8001 cellular modules provide additional custom functions over GPIO pins to improve the integration with u-blox positioning chips and modules. GPIO pins can handle:

- GNSS receiver power-on/off control: the “GNSS supply enable” function, settable on **GPIO2** pin.
- The wake-up from idle mode when the GNSS receiver is ready to send data: “GNSS Tx data ready” function, settable on the **GPIO3** pin.

## 1.11 Cellular audio interface

 The support of the cellular I2S digital audio interface function over **I2S\_TXD**, **I2S\_RXD**, **I2S\_CLK** and **I2S\_WA** pins is not presented with the “00C” product version of LENA-R8 series modules.

## 1.12 Cellular clock output

 The support of the cellular clock output functionality over the **GPIO6** pin is not presented with the “00C” product version of LENA-R8 series modules.

## 1.13 Cellular General Purpose Input/Output (GPIO)

LENA-R8 series modules include 6 pins (**GPIO1-GPIO6**) which can be configured as General Purpose Input/Output or to provide custom functions via u-blox AT commands (for more details, see the u-blox AT commands manual [2], +UGPIOC, +UGPIOR, +UGPIOW AT commands), as summarized in [Table 7](#).

Function	Description	Default GPIO	Configurable GPIOs
Network status indication	Network status: registered home network, registered roaming, data transmission, no service	--	GPIO1, GPIO2, GPIO3, GPIO4
GNSS supply enable	Enable/disable the supply of the u-blox GNSS receiver connected to the cellular system	--	GPIO1, GPIO2, GPIO3, GPIO4
GNSS data ready <sup>7</sup>	Sense when the external u-blox GNSS system connected to the cellular system is ready to send data by I2C	--	GPIO3
General purpose input	Input to sense high or low digital level	--	All
General purpose output	Output to set the high or the low digital level	--	All
Pin disabled	Tri-state with an internal active pull-down enabled	All	All

**Table 7: LENA-R8 series GPIO custom functions configuration**

<sup>7</sup> LENA-R8001 only

## 1.14 Reserved pins (RSVD)

LENA-R8 series modules include pins reserved for possible future use, marked as **RSVD**, which can all be left unconnected on the application board.

## 1.15 GNSS power management

 LENA-R8001 modules do not include a GNSS receiver: GNSS power management is not available.

### 1.15.1 GNSS supply input (VCC\_GNSS)

The **VCC\_GNSS** pin is the main supply input for the GNSS system integrated in LENA-R8001M10 modules, providing power to the GNSS RF domains and internal LNA, the GNSS system core, the GNSS digital peripheral I/O, the dedicated TCXO through an integrated LDO regulator, as is illustrated in [Figure 2](#).

Connecting an external DC power supply at the **VCC\_GNSS** input is necessary for normal operations. Voltage must be clean, stable, and tight at 1.8 V to properly supply the system with related parts.

During operation, the current drawn by the GNSS system may vary. For this reason, it is important that the supply circuitry is able to support the peak power for a short time.

For more information about GNSS supply input, see the u-blox M10 standard precision GNSS chip data sheet [\[3\]](#) and integration manual [\[4\]](#).

### 1.15.2 GNSS backup supply input (VBCKP\_GNSS)

The **VBCKP\_GNSS** pin is the backup supply input for the GNSS system of the LENA-R8001M10 modules, designed to keep the GNSS backup RAM memory and the GNSS RTC alive in case of voltage interruption at the main **VCC\_GNSS** input pin.

Connecting an external DC power supply at the **VBCKP\_GNSS** input is optional. If present, it enables the hardware backup mode when the main **VCC\_GNSS** supply is not present.

For more information about GNSS backup supply input, see the u-blox M10 standard precision GNSS chip data sheet [\[3\]](#) and integration manual [\[4\]](#).

## 1.16 GNSS antenna interface

 LENA-R8001 modules do not include a GNSS receiver: GNSS antenna interface is not available.

### 1.16.1 GNSS antenna RF interface (ANT\_GNSS)

The **ANT\_GNSS** pin represents the GNSS RF input of the LENA-R8001M10 modules, designed with 50 Ω characteristic impedance and with an internal DC block, suitable for both active and/or passive GNSS antennas due to the built-in SAW filter followed by an LNA followed by another SAW filter in front of the integrated high performing u-blox M10 concurrent GNSS engine.

For more information about GNSS RF capabilities, see the u-blox M10 standard precision GNSS chip data sheet [\[3\]](#) and integration manual [\[4\]](#).

### 1.16.2 GNSS LNA or antenna on/off control (ANT\_ON)

The **ANT\_ON** output pin of LENA-R8001M10 modules is a 1.8 V peripheral output pin of the internal u-blox M10 GNSS chipset, available to provide optional control for switching on/off the power supply to an external active GNSS antenna or an external separate LNA as it controls at the same time the internal LNA integrated in the module. This facility is provided to help minimize power consumption in power save mode operation.

## 1.17 GNSS serial communication interface

 LENA-R8001 modules do not include a GNSS receiver: GNSS UART interface is not available.

### 1.17.1 GNSS UART interface

LENA-R8001M10 modules supports a 1.8 V UART interface consisting of the **RXD\_GNSS** data input line and the **TXD\_GNSS** data output line, directly connected to the internal u-blox M10 GNSS chipset (as is illustrated in [Figure 2](#)).

The GNSS UART can be used as serial interface for direct communication between the internal u-blox M10 GNSS chipset and an external host.

The GNSS UART interface supports configurable baud rates. The default baud rate is 38'400 bit/s, with 8N1 (8 data bits, no parity, 1 stop bit) default frame format.

Neither handshaking signals nor hardware flow control signals are available in the UART interface.

For more information about GNSS UART interface, see the u-blox M10 standard precision GNSS chip data sheet [\[3\]](#), integration manual [\[4\]](#), and interface description [\[5\]](#).

 It is recommended to provide access to the **RXD\_GNSS** and **TXD\_GNSS** pins of LENA-R8001M10 modules for diagnostic purpose, by means of test points directly connected to the pins.

## 1.18 GNSS Peripheral Input/Output

 LENA-R8001 modules do not include a GNSS receiver: GNSS PIOs are not available.

LENA-R8001M10 modules provide the following 1.8 V peripheral output pins directly connected to the internal u-blox M10 GNSS chipset (as is illustrated in [Figure 2](#)):

- The **TIMEPULSE** output pin features time pulse signal. Make sure there is no load at this pin, which could cause the pin being low at startup.
- The **EXTINT** external interrupt input pin, which can be used for functions such as accurate external frequency aiding, time mark aiding, wake up from power save mode, and ON/OFF control of the GNSS receiver.

For more information about GNSS peripheral input/output, see the u-blox M10 standard precision GNSS chip data sheet [\[3\]](#), integration manual [\[4\]](#), and interface description [\[5\]](#).

## 2 Design-in

### 2.1 Overview

For an optimal integration of LENA-R8 series modules in the final application board, follow the design guidelines stated in this section.

Every application circuit must be properly designed to ensure the correct functionality of the related interface, but a number of points require greater attention during the design of the application device.

The following list provides a ranking of importance in the application design, starting from the highest priority:

1. Module antennas connection: **ANT**, **ANT\_GNSS** and **ANT\_DET** pins.  
Antenna circuit directly affects the RF compliance of the device integrating a LENA-R8 series module with the applicable certification schemes. Very carefully follow the suggestions provided in section [2.4](#) for schematic and layout design.
2. Module supply: **VCC**, **VCC\_GNSS** and **GND** pins.  
The supply circuit affects the RF compliance of the device integrating a LENA-R8 series module with applicable certification schemes as well as antenna circuit design. Very carefully follow the suggestions provided in section [2.2.1](#) for schematic and layout design.
3. USB interface: **USB\_D+**, **USB\_D-** and **VUSB\_DET** pins.  
Accurate design is required to ensure USB 2.0 high-speed interface functionality. Carefully follow the suggestions provided in the related section [2.6.2](#) for schematic and layout design.
4. SIM interface: **VSIM**, **SIM\_CLK**, **SIM\_IO**, **SIM\_RST** pins.  
Accurate design is required to ensure SIM card functionality and compliance with applicable conformance standards, also reducing the risk of RF coupling. Carefully follow the suggestions provided in section [2.5](#) for schematic and layout design.
5. System functions: **RESET\_N**, **PWR\_ON** pins.  
Accurate design is required to ensure that the voltage level is well defined during operation. Carefully follow the suggestions provided in section [2.3](#) for schematic and layout design.
6. Other digital interfaces: UARTs, I2C, I2S, GPIOs, GNSS PIOs and Reserved pins.  
Accurate design is required to ensure proper functionality and reduce the risk of digital data frequency harmonics coupling. Follow the suggestions provided in [2.6.1](#), [2.6.3](#), [2.7.1](#), [2.8](#) and [2.9](#) for schematic and layout design.
7. Other supply: the **V\_INT** output, **V\_BCKP** input, **VBCKP\_GNSS** input.  
Accurate design is required to ensure proper functionality. Follow the suggestions provided in sections [2.2.3](#) for schematic and layout design.

 It is recommended to follow the specific design guidelines provided by each manufacturer of any external part selected for the application board integrating the u-blox cellular modules.

## 2.2 Cellular power management

### 2.2.1 Cellular supply input (VCC)

#### 2.2.1.1 General guidelines for cellular VCC supply circuit selection and design

All of the available **VCC** pins must be connected to the external supply minimizing the power loss due to series resistance.

**GND** pins are internally connected but connect all the available pins to solid ground on the application board, since a good (low impedance) connection to external ground can minimize power loss and improve RF and thermal performance.

LENA-R8 series modules cellular system must be supplied through the **VCC** pins by a proper DC power supply that should comply with the module **VCC** requirements summarized in [Table 5](#).

The appropriate DC power supply can be selected according to the application requirements (see [Figure 18](#)). The most common supply sources are the following:

- Switching regulator
- Low Drop-Out (LDO) linear regulator
- Rechargeable Lithium-ion (Li-ion) or Lithium-ion polymer (Li-Pol) battery
- Primary (disposable) battery

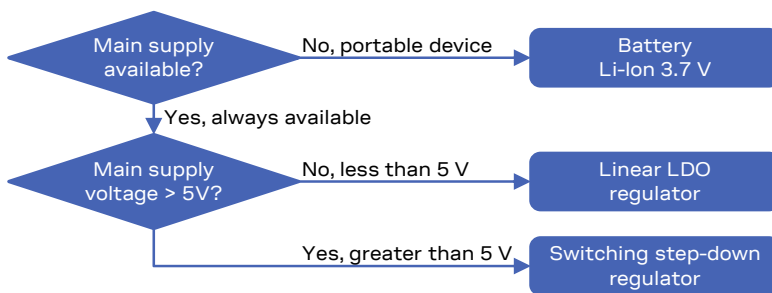

**Figure 18: VCC supply concept selection**

The DC/DC switching step-down regulator is the typical choice when the available primary supply source has a nominal voltage much higher (e.g., greater than 5 V) than the modules **VCC** operating supply voltage. The use of switching step-down provides the best power efficiency for the overall application and minimizes current drawn from the main supply source. See sections [2.2.1.2](#) and [2.2.1.8](#), [2.2.1.10](#), [2.2.1.11](#), [2.2.1.12](#) for the specific design-in.

The use of an LDO linear regulator becomes convenient for a primary supply with a relatively low voltage (e.g., less than 5 V). In this case the typical 90% efficiency of the switching regulator diminishes the benefit of voltage step-down and no true advantage is gained in input current savings. On the opposite side, linear regulators are not recommended for high voltage step-down as they dissipate a considerable amount of energy in thermal power. See sections [2.2.1.3](#) and [2.2.1.8](#), [2.2.1.10](#), [2.2.1.11](#), [2.2.1.12](#) for the specific design-in.

If LENA-R8 series modules are deployed in a mobile unit where no permanent primary supply source is available, then a battery will be required to provide **VCC**. A standard 3-cell Li-ion or Li-Pol battery pack directly connected to **VCC** is the usual choice for battery-powered devices. During charging, batteries with Ni-MH chemistry typically reach a maximum voltage that is above the maximum rating for **VCC**, and should therefore be avoided. See sections [2.2.1.4](#), [2.2.1.6](#), [2.2.1.7](#), [2.2.1.8](#), [2.2.1.9](#), [2.2.1.10](#), [2.2.1.11](#), [2.2.1.12](#) for the specific design-in.

Keep in mind that the use of rechargeable batteries requires the implementation of a suitable charger circuit which is not included in the modules. The charger circuit must be designed to prevent over-voltage on the **VCC** pins, and it should be selected according to the application requirements: a

DC/DC switching charger is the typical choice when the charging source has an high nominal voltage (e.g., ~12 V), whereas a linear charger is the typical choice when the charging source has a relatively low nominal voltage (~5 V). If both a permanent primary supply / charging source (e.g., ~12 V) and a rechargeable back-up battery (e.g., 3.7 V Li-Pol) are available at the same time as a possible supply source, then a proper charger / regulator with integrated power path management function can be selected to supply the module while simultaneously and independently charging the battery. See sections [2.2.1.6](#), [2.2.1.7](#), [2.2.1.4](#), [2.2.1.8](#), [2.2.1.9](#), [2.2.1.10](#), [2.2.1.11](#), [2.2.1.12](#) for specific design-in.

An appropriate primary (not rechargeable) battery can be selected taking into account the maximum current specified in the LENA-R8 series data sheet [1] during connected mode, considering that primary cells might have weak power capability. See sections [2.2.1.5](#), [2.2.1.8](#), [2.2.1.9](#), [2.2.1.10](#), [2.2.1.11](#), [2.2.1.12](#) for the specific design-in.

The usage of more than one DC supply at the same time should be carefully evaluated: depending on the supply source characteristics, different DC supply systems can be mutually exclusive.

The usage of a regulator or a battery not able to support the highest peak of **VCC** current consumption specified in the LENA-R8 series data sheet [1] is generally not recommended. However, if the selected regulator or battery is not able to support the highest peak current of the module, it must be able to support at least the highest averaged current consumption value specified in the LENA-R8 series data sheet [1] with an adequate margin (see [Table 5](#)). The additional energy required by the module during a 2G Tx slot can be provided by an appropriate bypass tank capacitor or super-capacitor with very large capacitance and very low ESR placed close to the module **VCC** pins. Depending on the actual capability of the selected regulator or battery, the required capacitance can be considerably larger than 1 mF and the required ESR can be in the range of few tens of mΩ. Carefully evaluate the super-capacitor characteristics, since aging and temperature may affect the actual characteristics.

The following sections highlight some design aspects for each of the supplies listed above, providing application circuit design-in compliant with the module **VCC** requirements summarized in [Table 5](#).

### 2.2.1.2 Guidelines for VCC supply circuit design using a DC/DC regulator

The use of a switching regulator is suggested when the difference from the available supply rail to the **VCC** value is high: switching regulators provide good efficiency transforming a 12 V or greater voltage supply to the typical 3.8 V value of the **VCC** supply.

The characteristics of the switching regulator connected to the **VCC** pins should meet the following prerequisites to comply with the module's **VCC** requirements summarized in [Table 5](#):

- **Power capability:** the switching regulator with its output circuit must be capable of providing a voltage value to the **VCC** pins within the specified operating range and must be capable of delivering to the **VCC** pins the specified maximum peak / pulse current consumption during Tx burst at the maximum Tx power specified in the LENA-R8 series data sheet [1]
- **Low output ripple:** the switching regulator together with its output circuit must be capable of providing a clean (low noise) **VCC** voltage profile.
- **High switching frequency:** for best performance and for smaller applications, it is recommended to select a switching frequency  $\geq 600$  kHz (since the L-C output filter is typically smaller for high switching frequencies). The use of a switching regulator with a variable switching frequency or with a switching frequency lower than 600 kHz must be evaluated carefully, since this can produce noise in the **VCC** voltage profile and therefore negatively impact modulation spectrum performance.

- PWM mode operation:** it is preferable to select regulators with a Pulse Width Modulation (PWM) mode. While in connected mode, the Pulse Frequency Modulation (PFM) mode and PFM/PWM modes transitions must be avoided in order to reduce noise on the **VCC** voltage profile. Switching regulators that are able to switch between low ripple PWM mode and high ripple PFM mode can be used, provided that the mode transition occurs when the module changes status from the idle/active modes to connected mode. It is acceptable to use a regulator that switches from the PWM mode to the burst or PFM mode at an appropriate current threshold.

Figure 19 and the components listed in Table 8 show an example of a high reliability power supply circuit, where the **VCC** module is supplied by a step-down switching regulator capable of delivering the specified maximum peak / pulse current to the **VCC** pins, with low output ripple and with fixed switching frequency in PWM mode operation greater than 1 MHz.

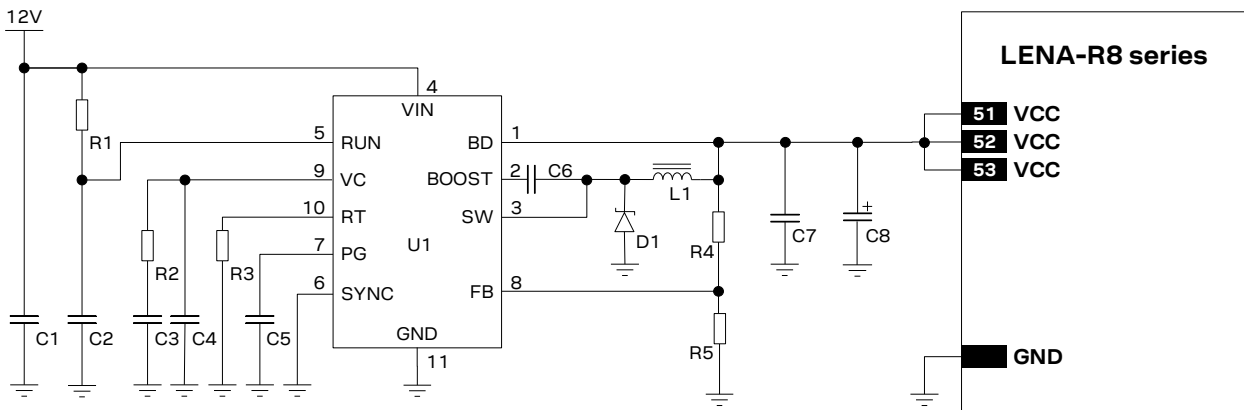

Figure 19: Example of high reliability VCC supply application circuit using a step-down regulator

Reference	Description	Part number – manufacturer
C1	10 $\mu$ F Capacitor Ceramic X7R 5750 15% 50 V	C5750X7R1H106MB – TDK
C2	10 nF Capacitor Ceramic X7R 0402 10% 16 V	GRM155R71C103KA01 – Murata
C3	680 pF Capacitor Ceramic X7R 0402 10% 16 V	GRM155R71H681KA01 – Murata
C4	22 pF Capacitor Ceramic COG 0402 5% 25 V	GRM1555C1H220JZ01 – Murata
C5	10 nF Capacitor Ceramic X7R 0402 10% 16 V	GRM155R71C103KA01 – Murata
C6	470 nF Capacitor Ceramic X7R 0603 10% 25 V	GRM188R71E474KA12 – Murata
C7	22 $\mu$ F Capacitor Ceramic X5R 1210 10% 25 V	GRM32ER61E226KE15 – Murata
C8	330 $\mu$ F Capacitor Tantalum D_SIZE 6.3 V 45 m $\Omega$	T520D337M006ATE045 – KEMET
D1	Schottky Diode 40 V 3 A	MBRA340T3G – ON Semiconductor
L1	10 $\mu$ H Inductor 744066100 30% 3.6 A	744066100 – Würth Electronics
R1	470 k $\Omega$ Resistor 0402 5% 0.1 W	Various manufacturers
R2	15 k $\Omega$ Resistor 0402 5% 0.1 W	Various manufacturers
R3	22 k $\Omega$ Resistor 0402 5% 0.1 W	Various manufacturers
R4	390 k $\Omega$ Resistor 0402 1% 0.063 W	Various manufacturers
R5	100 k $\Omega$ Resistor 0402 5% 0.1 W	Various manufacturers
U1	Step-Down Regulator MSOP10 3.5 A 2.4 MHz	LT3972IMSE#PBF – Linear Technology

Table 8: Components for high reliability VCC supply application circuit using a step-down regulator

See the section 2.2.1.8, and in particular Figure 26 / Table 14, for the parts recommended to be provided if the application device integrates an internal antenna.

Figure 20 and the components listed in Table 9 show an example of a low cost power supply circuit, where the VCC module supply is provided by a step-down switching regulator capable of delivering the specified maximum peak / pulse current to the VCC pins, transforming a 12 V supply input.

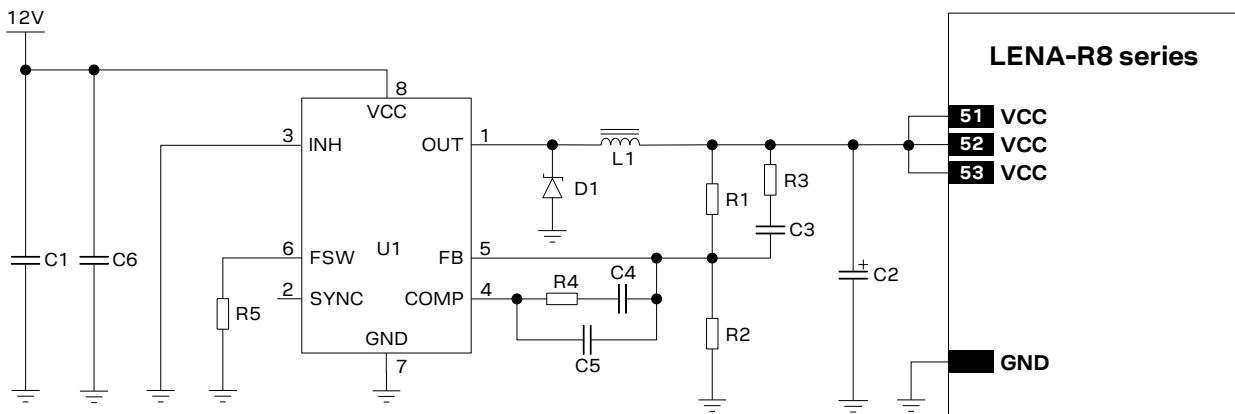

Figure 20: Example of low cost VCC supply application circuit using step-down regulator

Reference	Description	Part number – manufacturer
C1	22 $\mu$ F Capacitor Ceramic X5R 1210 10% 25 V	GRM32ER61E226KE15 – Murata
C2	100 $\mu$ F Capacitor Tantalum B_SIZE 20% 6.3V 15m $\Omega$ T520B107M006ATE015 – Kemet	
C3	5.6 nF Capacitor Ceramic X7R 0402 10% 50 V	GRM155R71H562KA88 – Murata
C4	6.8 nF Capacitor Ceramic X7R 0402 10% 50 V	GRM155R71H682KA88 – Murata
C5	56 pF Capacitor Ceramic C0G 0402 5% 50 V	GRM1555C1H560JA01 – Murata
C6	220 nF Capacitor Ceramic X7R 0603 10% 25 V	GRM188R71E224KA88 – Murata
D1	Schottky Diode 25V 2 A	STPS2L25 – STMicroelectronics
L1	5.2 $\mu$ H Inductor 30% 5.28A 22 m $\Omega$	MSS1038-522NL – Coilcraft
R1	4.7 k $\Omega$ Resistor 0402 1% 0.063 W	Various manufacturers
R2	910 $\Omega$ Resistor 0402 1% 0.063 W	Various manufacturers
R3	82 $\Omega$ Resistor 0402 5% 0.063 W	Various manufacturers
R4	8.2 k $\Omega$ Resistor 0402 5% 0.063 W	Various manufacturers
R5	39 k $\Omega$ Resistor 0402 5% 0.063 W	Various manufacturers
U1	Step-Down Regulator 8-VFQFPN 3 A 1 MHz	L5987TR – ST Microelectronics

Table 9: Components for a low cost VCC supply application circuit using a step-down regulator

See the section 2.2.1.8, and in particular Figure 26 / Table 14, for the parts recommended to be provided if the application device integrates an internal antenna.

### 2.2.1.3 Guidelines for VCC supply circuit design using a linear regulator

The use of a linear regulator is suggested when the difference from the available supply rail and the **VCC** value is low: linear regulators provide high efficiency when transforming a 5 V supply to a voltage value within the module **VCC** normal operating range.

The characteristics of the LDO linear regulator connected to the **VCC** pins should meet the following prerequisites to comply with the module's **VCC** requirements summarized in [Table 5](#):

- **Power capabilities:** the LDO linear regulator with its output circuit must be capable of providing a voltage value to the **VCC** pins within the specified operating range and must be capable of delivering the maximum peak / pulse current consumption to the **VCC** pins during a Tx burst at the maximum Tx power specified in the LENA-R8 series data sheet [\[1\]](#).
- **Power dissipation:** the power handling capability of the LDO linear regulator must be checked to limit its junction temperature to the maximum rated operating range (i.e. check the voltage drop from the max input voltage to the minimum output voltage to evaluate the power dissipation of the regulator).

[Figure 21](#) and the components listed in [Table 10](#) show an example of a high reliability power supply circuit, where the **VCC** module supply is provided by an LDO linear regulator capable of delivering the specified highest peak / pulse current, with the proper power handling capability. The regulator described in this example supports a wide input voltage range, and it includes internal circuitry for reverse battery protection, current limiting, thermal limiting and reverse current protection.

It is recommended to configure the LDO linear regulator to generate a voltage supply value slightly below the maximum limit of the module **VCC** normal operating range (e.g., ~4.1 V as in the circuit described in [Figure 21](#) and [Table 10](#)). This reduces the power on the linear regulator and improves the whole thermal design of the supply circuit.

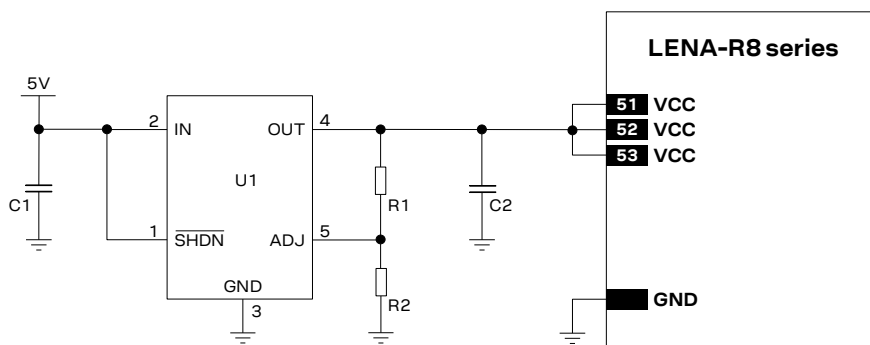

**Figure 21: Example of a high reliability VCC supply application circuit using an LDO linear regulator**

Reference	Description	Part number - manufacturer
C1, C2	10 $\mu$ F Capacitor Ceramic X5R 0603 20% 6.3 V	GRM188R60J106ME47 - Murata
R1	9.1 k $\Omega$ Resistor 0402 5% 0.1 W	Various manufacturers
R2	3.9 k $\Omega$ Resistor 0402 5% 0.1 W	Various manufacturers
U1	LDO Linear Regulator ADJ 3.0 A	LT1764AEQ#PBF - Linear Technology

**Table 10: Components for a high reliability VCC supply application circuit using an LDO linear regulator**

See the section [2.2.1.8](#), and in particular [Figure 26](#) / [Table 14](#), for the parts recommended to be provided if the application device integrates an internal antenna.

Figure 22 and the components listed in Table 11 show an example of a low-cost power supply circuit, where the **VCC** module supply is provided by an LDO linear regulator capable of delivering the specified highest peak / pulse current, with the proper power handling capability. The regulator described in this example supports a limited input voltage range and it includes internal circuitry for current and thermal protection.

It is recommended to configure the LDO linear regulator to generate a voltage supply value slightly below the maximum limit of the module VCC normal operating range (e.g., ~4.1 V as in the circuit described in Figure 22 and Table 11). This reduces the power on the linear regulator and improves the whole thermal design of the supply circuit.

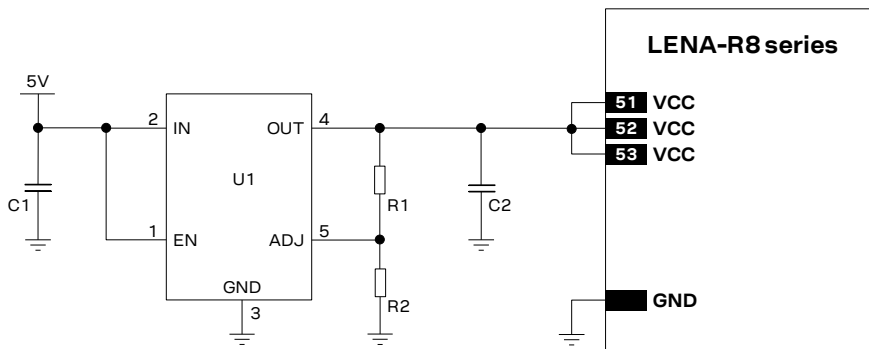

Figure 22: Example of a low cost VCC supply application circuit using an LDO linear regulator

Reference	Description	Part number – manufacturer
C1, C2	10 µF Capacitor Ceramic X5R 0603 20% 6.3 V	GRM188R60J106ME47 – Murata
R1	27 kΩ Resistor 0402 5% 0.1 W	Various manufacturers
R2	4.7 kΩ Resistor 0402 5% 0.1 W	Various manufacturers
U1	LDO Linear Regulator ADJ 3.0 A	LP38501ATJ-ADJ/NOPB – Texas Instrument

Table 11: Components for a low cost VCC supply application circuit using an LDO linear regulator

See the section 2.2.1.8, and in particular Figure 26 / Table 14, for the parts recommended to be provided if the application device integrates an internal antenna.

### 2.2.1.4 Guidelines for VCC supply circuit design using a rechargeable battery

Rechargeable Li-ion or Li-Pol batteries connected to the **VCC** pins should meet the following prerequisites to comply with the module **VCC** requirements summarized in Table 5:

- Maximum pulse and DC discharge current:** the rechargeable Li-ion battery with its related output circuit connected to the **VCC** pins must be capable of delivering a pulse current as the maximum peak / pulse current consumption during a Tx burst at the maximum Tx power specified in the LENA-R8 series data sheet [1], and must be capable of extensively delivering a DC current as the maximum average current consumption specified in the LENA-R8 series data sheet [1]. The maximum discharge current is not always reported in the data sheets of batteries, but the maximum DC discharge current is typically almost equal to the battery capacity in amp-hours divided by 1 hour.
- DC series resistance:** the rechargeable Li-ion battery with its output circuit must be capable of avoiding a VCC voltage drop below the operating range summarized in Table 5 during transmit bursts.

### 2.2.1.5 Guidelines for VCC supply circuit design using a primary battery

The characteristics of a primary (non-rechargeable) battery connected to the **VCC** pins should meet the following prerequisites to comply with the module's **VCC** requirements summarized in [Table 5](#):

- Maximum pulse and DC discharge current:** the non-rechargeable battery with its related output circuit connected to the **VCC** pins must be capable of delivering a pulse current as the maximum peak current consumption during a Tx burst at the maximum Tx power specified in the LENA-R8 series data sheet [1], and must be capable of extensively delivering a DC current as the maximum average current consumption specified in the LENA-R8 series data sheet [1]. The maximum discharge current is not always reported in the data sheets of batteries, but the max DC discharge current is typically almost equal to the battery capacity in amp-hours divided by 1 hour.
- DC series resistance:** the non-rechargeable battery with its output circuit must be capable of avoiding a **VCC** voltage drop below the operating range summarized in [Table 5](#) during transmit bursts.

### 2.2.1.6 Guidelines for external battery charging circuit

LENA-R8 series modules do not have an on-board charging circuit. [Figure 23](#) provides an example of a battery charger design, suitable for applications powered with a Li-ion (or Li-Polymer) battery.

In the application circuit, a rechargeable Li-ion (or Li-Polymer) battery cell, that features proper pulse and DC discharge current capabilities and proper DC series resistance, is directly connected to the **VCC** supply input of the module. Battery charging is completely managed by the STMicroelectronics L6924U Battery Charger IC that, from a USB power source (5.0 V typ.), charges as a linear charger the battery, in three phases:

- Pre-charge constant current** (active when the battery is deeply discharged): the battery is charged with a low current, set to 10% of the fast-charge current
- Fast-charge constant current:** the battery is charged with the maximum current, configured by the value of an external resistor to a value suitable for USB power source (~500 mA)
- Constant voltage:** when the battery voltage reaches the regulated output voltage (4.2 V), the L6924U starts to reduce the current until the charge termination is done. The charging process ends when the charging current reaches the value configured by an external resistor to ~15 mA or when the charging timer reaches the value configured by an external capacitor to ~9800 s.

Using a battery pack with an internal NTC resistor, the L6924U can monitor the battery temperature to protect the battery from operating under unsafe thermal conditions.

The L6924U, as a linear charger, is more suitable for applications where the charging source has a relatively low nominal voltage (~5 V), so that a switching charger is suggested for applications where the charging source has a relatively high nominal voltage (e.g., ~12 V, see the following section [2.2.1.7](#) for specific design-in).

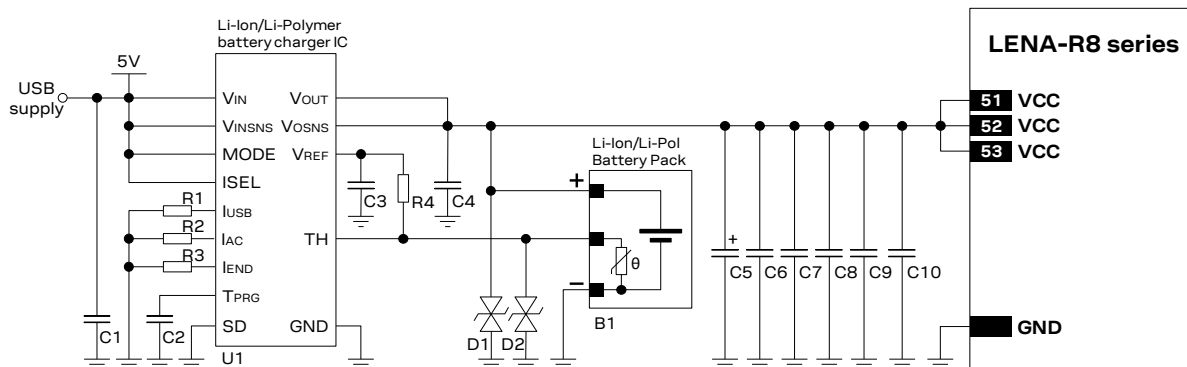

**Figure 23: Li-ion (or Li-Polymer) battery charging application circuit**

Reference	Description	Part number - manufacturer
B1	Li-ion (or Li-Polymer) battery pack with 470 $\Omega$ NTC	Various manufacturer
C1, C4	1 $\mu$ F Capacitor Ceramic X7R 0603 10% 16 V	GRM188R71C105KA12 - Murata
C2, C6	10 nF Capacitor Ceramic X7R 0402 10% 16 V	GRM155R71C103KA01 - Murata
C3	1 nF Capacitor Ceramic X7R 0402 10% 50 V	GRM155R71H102KA01 - Murata
C5	330 $\mu$ F Capacitor Tantalum D_SIZE 6.3 V 45 m $\Omega$	T520D337M006ATE045 - KEMET
C7	100 nF Capacitor Ceramic X7R 0402 10% 16 V	GRM155R61A104KA01 - Murata
C8	68 pF Capacitor Ceramic C0G 0402 5% 50 V	GRM1555C1H680JA01 - Murata
C9	15 pF Capacitor Ceramic C0G 0402 5% 25 V	GRM1555C1E150JA01 - Murata
C10	8.2 pF Capacitor Ceramic C0G 0402 5% 50 V	GRM1555C1H8R2DZ01 - Murata
D1, D2	Low Capacitance ESD Protection	CG0402MLE-18G - Bourns
R1, R2	24 k $\Omega$ Resistor 0402 5% 0.1 W	Various manufacturers
R3	3.3 k $\Omega$ Resistor 0402 5% 0.1 W	Various manufacturers
R4	1.0 k $\Omega$ Resistor 0402 5% 0.1 W	Various manufacturers
U1	Single Cell Li-ion (or Li-Polymer) Battery Charger IC for USB port and AC Adapter	L6924U - STMicroelectronics

**Table 12: Suggested components for a Li-ion (or Li-Polymer) battery charging application circuit**

 See the section [2.2.1.8](#), and in particular [Figure 26 / Table 14](#), for the parts recommended to be provided if the application device integrates an internal antenna.

### 2.2.1.7 Guidelines for external charging and power path management circuit

Application devices where both a permanent primary supply / charging source (e.g., ~12 V) and a rechargeable back-up battery (e.g., 3.7 V Li-Pol) are available at the same time as the possible supply source should implement a suitable charger / regulator with an integrated power path management function to supply the module and the whole device while simultaneously and independently charging the battery.

[Figure 24](#) illustrates a simplified block diagram circuit showing the working principle of a charger / regulator with integrated power path management function. This component allows the system to be powered by a permanent primary supply source (e.g., ~12 V) using the integrated regulator which simultaneously and independently recharges the battery (e.g., 3.7 V Li-Pol) that represents the back-up supply source of the system: the power path management feature permits the battery to supplement the system current requirements when the primary supply source is not available or cannot deliver the peak system currents.

A power management IC should meet the following prerequisites to comply with the module **VCC** requirements summarized in [Table 5](#):

- High efficiency internal step-down converter, compliant with the performances specified in section [2.2.1.2](#)
- Low internal resistance in the active path  $V_{out} - V_{bat}$ , typically lower than 50 m $\Omega$
- High efficiency switch mode charger with separate power path control

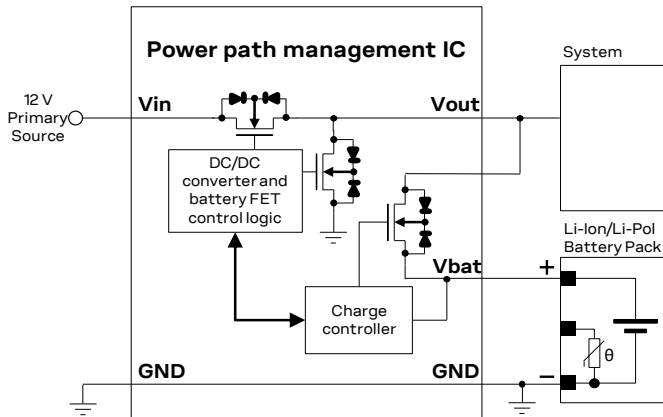

Figure 24: Charger / regulator with an integrated power path management circuit block diagram

Figure 25 and the components listed in Table 13 provide an application circuit example where the MPS MP2617H switching charger / regulator with an integrated power path management function provides the supply to the cellular module, while concurrently and autonomously charging a suitable Li-ion (or Li-Polymer) battery with the proper pulse and DC discharge current capabilities and the proper DC series resistance according to the rechargeable battery recommendations described in section 2.2.1.4.

The MP2617H IC constantly monitors the battery voltage and selects whether to use the external main primary supply / charging source or the battery as the supply source for the module, and starts a charging phase accordingly.

The MP2617H IC normally provides a supply voltage to the module regulated from the external main primary source allowing immediate system operation even under missing or deeply discharged battery conditions: the integrated switching step-down regulator is capable of providing up to 3 A output current with low output ripple and fixed 1.6 MHz switching frequency in PWM mode operation. The module load is satisfied in priority, then the integrated switching charger will take the remaining current to charge the battery.

Additionally, the power path control allows an internal connection from the battery to the module with a low series internal ON resistance (40 mΩ typical), in order to supplement additional power to the module when the current demand increases over the external main primary source or when this external source is removed.

Battery charging is managed in three phases:

- **Pre-charge constant current** (active when the battery is deeply discharged): the battery is charged with a low current, set to 10% of the fast-charge current
- **Fast-charge constant current:** the battery is charged with the maximum current, configured by the value of an external resistor to a value suitable for the application
- **Constant voltage:** when the battery voltage reaches the regulated output voltage (4.2 V), the current is progressively reduced until the charge termination is done. The charging process ends when the charging current reaches the 10% of the fast-charge current or when the charging timer reaches the value configured by an external capacitor.

Using a battery pack with an internal NTC resistor, the MP2617H IC can monitor the battery temperature to protect the battery from operating under unsafe thermal conditions.

Several parameters, such as the charging current, the charging timings, the input current limit, the input voltage limit, and the system output voltage, can be easily set according to the specific application requirements, as the actual electrical characteristics of the battery and the external supply / charging source: proper resistors or capacitors must be accordingly connected to the related pins of the IC.

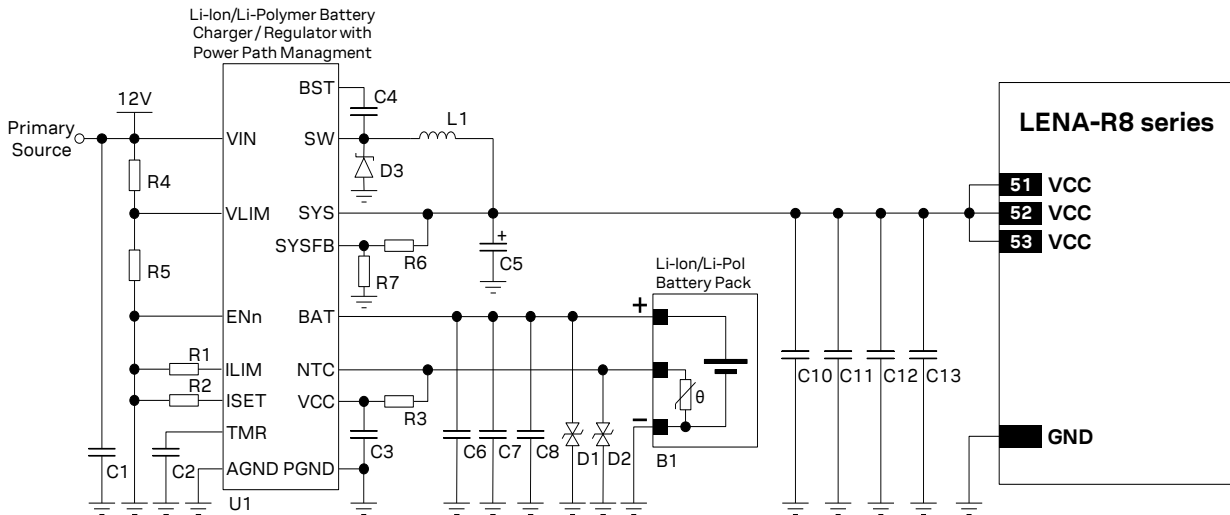
**Figure 25: Li-ion (or Li-Polymer) battery charging and power path management application circuit**

Reference	Description	Part number – manufacturer
B1	Li-ion (or Li-Polymer) battery pack with 10 kΩ NTC	Various manufacturer
C1, C6	22 μF Capacitor Ceramic X5R 1210 10% 25 V	GRM32ER61E226KE15 – Murata
C2, C4, C10	100 nF Capacitor Ceramic X7R 0402 10% 16 V	GRM155R61A104KA01 – Murata
C3	1 μF Capacitor Ceramic X7R 0603 10% 25 V	GRM188R71E105KA12 – Murata
C5	330 μF Capacitor Tantalum D_SIZE 6.3 V 45 mΩ	T520D337M006ATE045 – KEMET
C7, C12	68 pF Capacitor Ceramic C0G 0402 5% 50 V	GRM1555C1H680JA01 – Murata
C8, C13	15 pF Capacitor Ceramic C0G 0402 5% 25 V	GRM1555C1E150JA01 – Murata
C11	10 nF Capacitor Ceramic X7R 0402 10% 16 V	GRM155R71C103KA01 – Murata
D1, D2	Low Capacitance ESD Protection	CG0402MLE-18G – Bourns
D3	Schottky Diode 40 V 3 A	MBRA340T3G – ON Semiconductor
R1, R3, R5, R7	10 kΩ Resistor 0402 1% 1/16 W	Various manufacturers
R2	1.05 kΩ Resistor 0402 1% 0.1 W	Various manufacturers
R4	22 kΩ Resistor 0402 1% 1/16 W	Various manufacturers
R6	26.5 kΩ Resistor 0402 1% 1/16 W	Various manufacturers
L1	2.2 μH Inductor 7.4 A 13 mΩ 20%	SRN8040-2R2Y – Bourns
U1	Li-ion/Li-Polymer Battery DC/DC Charger / Regulator with integrated Power Path Management function	MP2617H – Monolithic Power Systems (MPS)

**Table 13: Suggested components for Li-ion (or Li-Pol) battery charging and power path management application circuit**

See the section 2.2.1.8, and in particular Figure 26 / Table 14, for the parts recommended to be provided if the application device integrates an internal antenna.

### 2.2.1.8 Additional guidelines for VCC supply circuit design

To reduce voltage drops, use a low impedance power source. The series resistance of the power supply lines (connected to the **VCC** and **GND** pins of the module) on the application board and battery pack should also be considered and minimized: cabling and routing must be as short as possible to minimize power losses.

Three pins are allocated for the **VCC** supply. Several pins are designated for the **GND** connection. It is recommended to properly connect all of them to supply the module to minimize series resistance losses.

Additional parts described in [Figure 26](#) and [Table 14](#) are recommended to be provided near the **VCC** pins of the module for various RF and/or EMI improvements purposes.

For modules supporting 2G or LTE TDD, to avoid voltage drop undershoot and overshoot at the start and end of a transmit burst and mitigate possible RF spurious emission, place a bypass capacitor with large capacitance (at least 100  $\mu\text{F}$ ) and low ESR near the **VCC** pins, for example:

- 330  $\mu\text{F}$  capacitance, 45 m $\Omega$  ESR (e.g., KEMET T520D337M006ATE045, Tantalum Capacitor)

To reduce voltage ripple and noise, improving RF performance especially if the application device integrates an internal antenna, place the following bypass capacitors near the **VCC** pins, narrowing the **VCC** line down to the pad of the capacitors, to improve the RF noise rejection in the band centered on the Self-Resonant Frequency of the capacitors:

- 82 pF 0402 ceramic capacitor with Self-Resonant Frequency in the 800/900 MHz range
- 15 pF 0402 ceramic capacitor with Self-Resonant Frequency in the 1800/1900 MHz range
- 8.2 pF 0402 ceramic capacitor with Self-Resonant Frequency in the 2500/2600 MHz range
- 10 nF 0402 ceramic capacitor, to filter digital logic noise from clocks and data sources
- 100 nF 0402 ceramic capacitor, to filter digital logic noise from clocks and data sources

An additional series ferrite bead can be properly placed on the **VCC** line for additional RF noise filtering, in particular if the application device integrates an internal antenna:

- Ferrite bead specifically designed for EMI / noise suppression in the ~GHz band (as the Murata BLM18EG221SN1), placed as close as possible to the **VCC** pins of the module, implementing the circuit described in [Figure 26](#), to filter out EMI in all the cellular bands

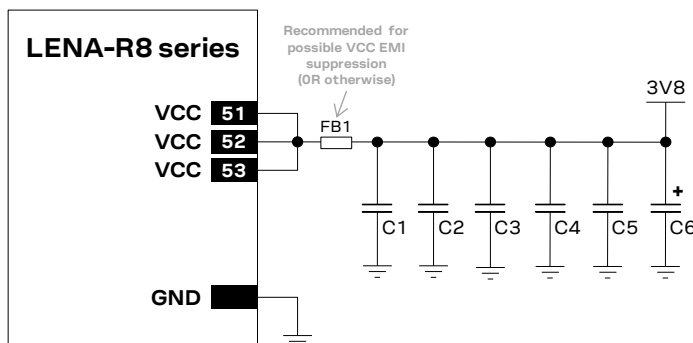

**Figure 26: Suggested schematic for the VCC bypass capacitors to reduce ripple / noise on the supply voltage profile**

Reference	Description	Part number - manufacturer
C1	8.2 pF Capacitor Ceramic C0G 0402 5% 50 V	GRM1555C1H8R2DZ01 - Murata
C2	15 pF Capacitor Ceramic C0G 0402 5% 50 V	GRM1555C1H150JA01 - Murata
C3	82 pF Capacitor Ceramic C0G 0402 5% 50 V	GRM1555C1H820JA01 - Murata
C4	10 nF Capacitor Ceramic X7R 0402 10% 16 V	GRM155R71C103KA01 - Murata
C5	100 nF Capacitor Ceramic X7R 0402 10% 16 V	GRM155R71C104KA01 - Murata
C6	330 $\mu\text{F}$ Capacitor Tantalum D_SIZE 6.3 V 45 m $\Omega$	T520D337M006ATE045 - KEMET
	10 $\mu\text{F}$ Capacitor Ceramic X5R 0603 20% 6.3 V	GRM188R60J106ME47 - Murata
FB1	Chip Ferrite Bead EMI Filter for GHz Band Noise 220 $\Omega$ at 100 MHz, 260 $\Omega$ at 1 GHz, 2000 mA	BLM18EG221SN1 - Murata

**Table 14: Suggested components to reduce ripple / noise on VCC**

The necessity of each part depends on the specific design, but it is recommended to provide all the bypass capacitors described in [Figure 26](#) / [Table 14](#), and consider a ferrite bead designed for EMI suppression in the ~GHz band, if the application device integrates an internal antenna.

ESD sensitivity rating of the **VCC** pins is 1 kV (HBM as per JESD22-A114). Higher protection level can be required if the line is externally accessible on the application board, as if the accessible battery connector is directly connected to **VCC** pins. A higher protection level can be achieved by mounting an ESD protection (as EPCOS CA05P4S14THSG varistor) close to the accessible point.

### 2.2.1.9 Additional solution for VCC supply circuit design

LENA-R8 series modules provide separate supply inputs over the **VCC** pins (see [Figure 5](#)):

- **VCC** pins #52 and #53 represent the supply input for the internal RF power amplifiers, demanding most of the total current drawn when RF transmission is enabled during a voice/data call
- **VCC** pin #51 represents the supply input for the internal baseband Power Management Unit and the internal transceiver, demanding a minor part of the total current drawn of the module when RF transmission is enabled during a voice/data call

LENA-R8 series modules support two different extended operating voltage ranges: one for the **VCC** pins #52 and #53, and another one for the **VCC** pin #51 (see the LENA-R8 series data sheet [\[1\]](#)).

All the **VCC** pins are in general intended to be connected to the same external power supply circuit, but separate supply sources can be implemented for very particular battery-powered applications considering that the voltage at the **VCC** pins #52 and #53 can drop to a value lower than the one at the **VCC** pin #51, keeping the module still switched-on and functional. [Figure 27](#) describes a possible application circuit.

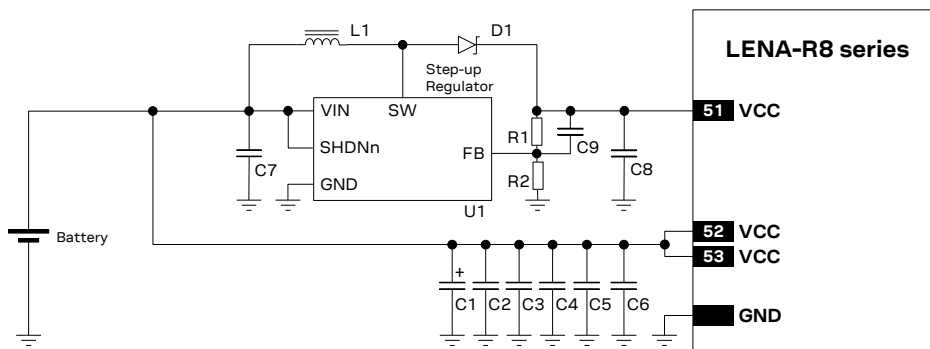

**Figure 27: VCC circuit example with a separate supply for LENA-R8 series modules**

Reference	Description	Part number – manufacturer
C1	330 $\mu$ F Capacitor Tantalum D_SIZE 6.3 V 45 m $\Omega$	T520D337M006ATE045 – KEMET
C2	10 nF Capacitor Ceramic X7R 0402 10% 16 V	GRM155R71C103KA01 – Murata
C3	100 nF Capacitor Ceramic X7R 0402 10% 16 V	GRM155R61A104KA01 – Murata
C4	68 pF Capacitor Ceramic C0G 0402 5% 50 V	GRM1555C1H680JA01 – Murata
C5	15 pF Capacitor Ceramic C0G 0402 5% 25 V	GRM1555C1E150JA01 – Murata
C6	8.2 pF Capacitor Ceramic C0G 0402 5% 50 V	GRM1555C1H8R2DZ01 – Murata
C7	10 $\mu$ F Capacitor Ceramic X5R 0603 20% 6.3 V	GRM188R60J106ME47 – Murata
C8	22 $\mu$ F Capacitor Ceramic X5R 1210 10% 25 V	GRM32ER61E226KE15 – Murata
C9	10 pF Capacitor Ceramic C0G 0402 5% 25 V	GRM1555C1E100JA01 – Murata
D1	Schottky Diode 40 V 1 A	SS14 – Vishay General Semiconductor
L1	10 $\mu$ H Inductor 20% 1 A 276 m $\Omega$	SRN3015-100M – Bourns Inc.
R1	1 M $\Omega$ Resistor 0402 5% 0.063 W	Various manufacturers
R2	412 k $\Omega$ Resistor 0402 5% 0.063 W	Various manufacturers
U1	Step-up Regulator 350 mA	AP3015 – Diodes Incorporated

**Table 15: Example of components for VCC circuit with a separate supply for LENA-R8 series modules**

### 2.2.1.10 Guidelines for removing VCC supply

As described in section 1.7.2, Figure 14 and Figure 15, the **VCC** supply can be removed after the end of LENA-R8 series modules internal power-off sequence, which must be properly started sending the AT+CPWROFF command (see the u-blox AT commands manual [2]). Removing the **VCC** power can be useful in order to minimize the current consumption when the LENA-R8 series modules are switched off. Afterwards, the modules can be switched on again by re-applying the **VCC** supply.

If the **VCC** supply is generated by a switching or an LDO regulator, the application processor may control the input pin of the regulator which is provided to enable / disable the output of the regulator (as for example, the RUN input pin for the regulator described in Figure 19, or the SHDNn input pin for the regulator described in Figure 21), in order to apply / remove the **VCC** supply.

If the regulator that generates the **VCC** supply does not provide an on / off pin, or for other applications such as the battery-powered ones, the **VCC** supply can be switched off using an appropriate external p-channel MOSFET controlled by the application processor by means of a proper inverting transistor as shown in Figure 28, given that the external pMOS has to provide:

- Very low  $R_{DS(ON)}$  (for example, less than 50 m $\Omega$ ), to minimize voltage drops
- Adequate maximum Drain current (see LENA-R8 series data sheet [1] for module consumption)
- Low leakage current, to minimize the consumption

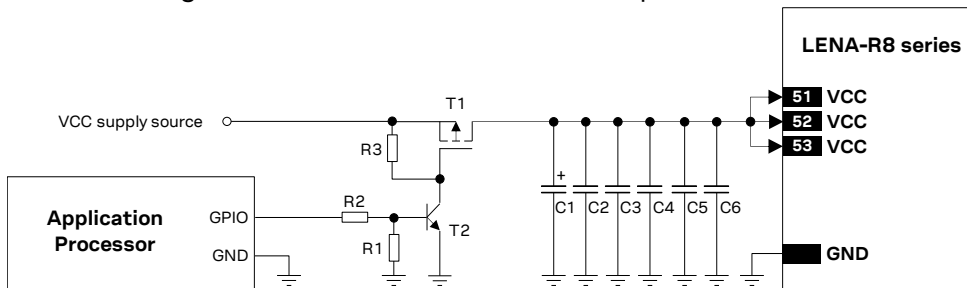

Figure 28: Example of application circuit for a VCC supply removal

Reference	Description	Part number – manufacturer
R1	47 k $\Omega$ Resistor 0402 5% 0.1 W	Various manufacturers
R2	10 k $\Omega$ Resistor 0402 5% 0.1 W	Various manufacturers
R3	100 k $\Omega$ Resistor 0402 5% 0.1 W	Various manufacturers
T1	P-Channel MOSFET Low On-Resistance	AO3415 – Alpha & Omega Semiconductor Inc.
T2	NPN BJT Transistor	BC847 – Infineon
C1	330 $\mu$ F Capacitor Tantalum D_SIZE 6.3 V 45 m $\Omega$	T520D337M006ATE045 – KEMET
C2	10 nF Capacitor Ceramic X7R 0402 10% 16 V	GRM155R71C103KA01 – Murata
C3	100 nF Capacitor Ceramic X7R 0402 10% 16 V	GRM155R61A104KA01 – Murata
C4	56 pF Capacitor Ceramic C0G 0402 5% 25 V	GRM1555C1E560JA01 – Murata
C5	15 pF Capacitor Ceramic C0G 0402 5% 25 V	GRM1555C1E150JA01 – Murata
C6	8.2 pF Capacitor Ceramic C0G 0402 5% 50 V	GRM1555C1H8R2DZ01 – Murata

Table 16: Components for a VCC supply removal application circuit

It is highly recommended to avoid an abrupt removal of the **VCC** supply during LENA-R8 series modules normal operations: the power-off procedure must be started by the AT+CPWROFF command, waiting the command response for a proper time period (see the u-blox AT commands manual [2]), and then a proper **VCC** supply must be held at least until the end of the modules' internal power-off sequence, which occurs when the generic digital interfaces supply output (**V\_INT**) is switched off by the module.

### 2.2.1.11 Guidelines for VCC supply layout design

Good connection of the module **VCC** supply pins with a DC supply source is required for correct RF performance. Guidelines are summarized in the following list:

- All the available **VCC** pins must be connected to the DC source.
- The series resistance along the **VCC** path must be as minimum as possible.
- Any series component with Equivalent Series Resistance (ESR) greater than few milliohms must be avoided.
- **VCC** connection must be routed through a PCB area separated from RF lines / parts, sensitive analog signals and sensitive functional units: it is good practice to interpose at least one layer of PCB ground between the **VCC** track and other signal routing.
- **VCC** connection must be routed as far as possible from the antenna, in particular if embedded in the application device: see [Figure 29](#).
- **VCC** connection must be routed through a PCB area separated from sensitive analog signals and sensitive functional units: it is good practice to interpose at least one layer of PCB ground between **VCC** track and other signal routing.
- Coupling between **VCC** and audio lines (especially microphone inputs) must be avoided, because the typical GSM burst has a periodic nature of approximately 217 Hz, which lies in the audio range.
- The tank bypass capacitor with low ESR for current spikes smoothing described in section [2.2.1.8](#) should be placed close to the **VCC** pins. If the main DC source is a switching DC-DC converter, place the large capacitor close to the DC-DC output and minimize the **VCC** track length. Otherwise, consider using separate large capacitors for the DC-DC converter and the cellular module.
- The bypass capacitors in the pF range described in section [2.2.1.8](#) should be placed as close as possible to the **VCC** pins, narrowing the **VCC** line down to the pad of the capacitors to improve the RF noise rejection in the band centered on the Self-Resonant Frequency of the pF capacitors. This is highly recommended if the device integrates an internal antenna.
- Since **VCC** is directly connected to RF Power Amplifiers, voltage ripple at high frequency may result in unwanted spurious modulation of the transmitter RF signal. This is more likely to happen with switching DC-DC converters, in which case it is better to select the highest operating frequency for the switcher and add a large L-C filter before connecting to the LENA-R8 series modules in the worst case.
- Shielding of the switching DC-DC converter circuit, or at least the use of shielded inductors for the switching DC-DC converter, may be considered since all switching power supplies may potentially generate interfering signals as a result of high-frequency, high-power switching.
- If **VCC** is protected by transient voltage suppressor to ensure that the voltage maximum ratings are not exceeded, place the protecting device along the path from the DC source toward the cellular module, preferably closer to the DC source (otherwise protection functionality may be compromised).

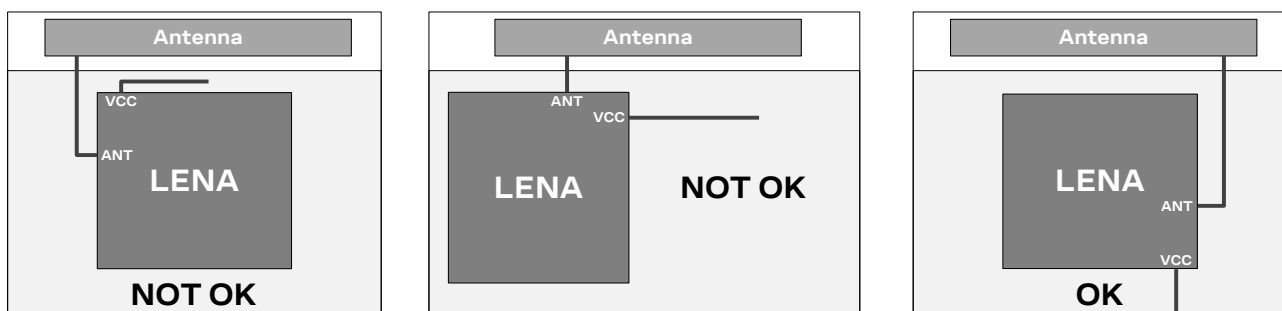

Figure 29: VCC line routing guideline for designs integrating an embedded antenna

### 2.2.1.12 Guidelines for grounding layout design

Good connection of the module **GND** pins with the application board solid ground layer is required for correct RF performance. It significantly improves RF and thermal heat sink figures for the module.

- Connect each **GND** pin with the application board solid GND layer. It is strongly recommended that each **GND** pin surrounding **VCC** pins have one or more dedicated via down to the application board solid ground layer.
- The **VCC** supply current flows back to the main DC source through GND as ground current: provide an adequate return path with a suitable uninterrupted ground plane to the main DC source.
- It is recommended to implement one layer of the application PCB as a ground plane as wide as possible.
- If the application board is a multilayer PCB, then all the board layers should be filled with GND plane as much as possible and each GND area should be connected together with a complete via stack down to the main ground layer of the PCB. Use as many vias as possible to connect ground planes.
- Provide a dense line of vias at the edges of each GND area, in particular along RF and high speed lines.
- If the whole application device is composed of more than one PCB, then it is required to provide a good and solid ground connection between the GND areas of all the multiple PCBs.
- Good grounding of **GND** pins also ensures thermal heat sink. This is critical during call connection, when the real network commands the module to transmit at maximum power: proper grounding helps prevent module overheating.

## 2.2.2 Cellular RTC supply (V\_BCKP)

### 2.2.2.1 Guidelines for V\_BCKP circuit design

LENA-R8 series cellular system provides the **V\_BCKP** RTC supply input/output for the cellular system, which can be mainly used to:

- Provide cellular system RTC back-up when **VCC** supply is removed

External power supply at **V\_BCKP** is optional. Keeping the RTC of the cellular system running when **VCC** supply is removed is not required for most of the applications, so that the **V\_BCKP** pin can be left unconnected in most of the applications.

In case the end-device application requires to keep the RTC of the cellular system running when the main **VCC** supply is removed, one of the following possible alternative options may be considered:

- 70 mF super-capacitor placed at **V\_BCKP**, with a 4.7 k $\Omega$  series resistor, to let the cellular RTC run after **VCC** removal
- Back-up battery placed at **V\_BCKP**, with a series diode, to let the cellular RTC run for much longer time after **VCC** removal

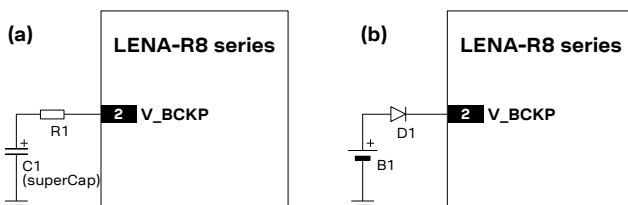



Figure 30: LENA-R8 series cellular system Real Time Clock supply (V\_BCKP) application circuits

Reference	Description	Part number - manufacturer
R1	4.7 k $\Omega$ Resistor 0402 5% 0.1 W	RC0402JR-074K7L - Yageo Phycomp
C1	70 mF Capacitor	XH414H-IV01E - Seiko Instruments

Table 17: Example of components for V\_BCKP buffering

 The internal regulator for **V\_BCKP** is optimized for low leakage current and very light loads. Do not apply loads which might exceed the limit for the maximum available current from **V\_BCKP** supply, as this can cause malfunctions in the module. The LENA-R8 series data sheet [1] describes the detailed electrical characteristics.

The **V\_BCKP** supply output provides internal short circuit protection to limit the start-up current and protect the device in short circuit situations. No additional external short circuit protection is required.

 ESD sensitivity rating of the **V\_BCKP** supply pin is 1 kV (HBM according to JESD22-A114). Higher protection level can be required if the line is externally accessible on the application board, e.g., if an accessible back-up battery connector is directly connected to the **V\_BCKP** pin, and it can be achieved by mounting an ESD protection (e.g., EPCOS CA05P4S14THSG varistor array) close to the accessible point.

### 2.2.2.2 Guidelines for V\_BCKP layout design

The RTC supply (**V\_BCKP**) requires careful layout: avoid injecting noise on this voltage domain, as it may affect the stability of the 32 kHz oscillator.

## 2.2.3 Cellular interface supply output (V\_INT)

### 2.2.3.1 Guidelines for V\_INT circuit design

LENA-R8 series cellular system provides the **V\_INT** 1.8 V supply output, which can be mainly used to:

- Indicate when the cellular system is switched on (see 1.5, 1.7.1, and 1.7.2 for more details)
- Pull-up SIM detection signal (see section 2.5 for more details)
- Supply external voltage translators to connect the 1.8 V digital interfaces of the module cellular system to an external 3.0 V device (see section 2.6.1, 2.6.3, 2.7.1 for more details)
- Pull-up I2C interface signals (see section 2.6.3 for more details)
- Supply an external 1.8 V u-blox GNSS receiver connected to the LENA-R8001 module (see section 2.10.1 for more details)
- Supply the internal u-blox GNSS receiver integrated in the LENA-R8001M10 module (see section 2.6.3 for more details)
- Supply an external device as an external 1.8 V audio codec (see section 2.7.1 for more details)

The **V\_INT** output pin provides internal short circuit protection to limit the start-up current and protect the device in short circuit situations. No additional external short circuit protection is required.

 Do not apply loads which might exceed the limit for maximum available current from **V\_INT** supply (see the LENA-R8 series data sheet [1]) as this can cause malfunctions in the internal circuitry.

 **V\_INT** can only be used as an output: do not connect any external supply source on **V\_INT**.

 ESD sensitivity rating of the **V\_INT** pin is 1 kV (HBM as per JESD22-A114). Higher protection level could be required if the line is externally accessible and it can be achieved by mounting an ESD protection (e.g., EPCOS CA05P4S14THSG varistor array) close to the accessible point.

 It is recommended to provide direct access to the **V\_INT** pin on the application board by means of an accessible Test-Point directly connected to the **V\_INT** pin, for diagnostic purpose.

### 2.2.3.2 Guidelines for V\_INT layout design

The **V\_INT** supply output is generated by an integrated linear LDO regulator, used internally to supply the generic digital interfaces. Because of this, the **V\_INT** is generally not critical for layout.

## 2.3 Cellular system functions interfaces

### 2.3.1 Cellular power-on (PWR\_ON)

#### 2.3.1.1 Guidelines for PWR\_ON circuit design

LENA-R8 series modules' **PWR\_ON** input line is internally pulled up as illustrated in [Figure 31](#): an external pull-up resistor is not required and should not be provided.

If connecting the **PWR\_ON** input to a push button, the pin will be externally accessible on the application device. According to EMC/ESD requirements of the application, an additional ESD protection should be provided close to the accessible point, as described in [Figure 31](#) and [Table 18](#).

 The ESD sensitivity rating of the **PWR\_ON** pin is 1 kV (HBM according to JESD22-A114). Higher protection level can be required if the line is externally accessible on the application board, as if an accessible push button is directly connected to the **PWR\_ON** pin, and it can be achieved by mounting an ESD protection (as EPCOS CA05P4S14THSG varistor) close to the accessible point.

An open drain or open collector output is suitable to drive the **PWR\_ON** input from an application processor, as the pin is internally pulled up as illustrated in [Figure 31](#).

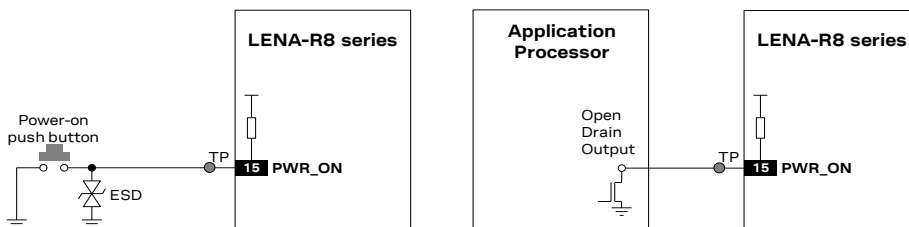



Figure 31: PWR\_ON application circuits using a push button and an open drain output of an application processor

Reference	Description	Part number - manufacturer
ESD	Varistor array for ESD protection	CT0402S14AHSG - EPCOS

Table 18: Example of pull-up resistor and ESD protection for the PWR\_ON application circuit

 It is recommended to provide direct access to the **PWR\_ON** pin on the application board by means of Test-Point directly connected to the **PWR\_ON** pin, for FW upgrade and for diagnostic purpose.

#### 2.3.1.2 Guidelines for PWR\_ON layout design

The **PWR\_ON** circuit requires careful layout since it is the sensitive input available to switch on the cellular system. It is required to ensure that the voltage level is well defined during operation and no transient noise is coupled on this line, otherwise the module might detect a spurious request.

### 2.3.2 Cellular reset (RESET\_N)

#### 2.3.2.1 Guidelines for RESET\_N circuit design

LENA-R8 series modules' **RESET\_N** input line is internally pulled up as illustrated in [Figure 32](#): an external pull-up resistor is not required and should not be provided.

If connecting the **RESET\_N** input to a push button, the pin will be externally accessible on the application device. According to EMC/ESD requirements of the application, an additional ESD protection device (e.g., the EPCOS CA05P4S14THSG varistor) should be provided close to the accessible point on the line connected to this pin, as described in [Figure 32](#) and [Table 19](#).

 The ESD sensitivity rating of the **RESET\_N** pin is 1 kV (HBM according to JESD22-A114). Higher protection level can be required if the line is externally accessible on the application board, e.g., if

an accessible push button is directly connected to the **RESET\_N** pin, and it can be achieved by mounting an ESD protection (as EPCOS CA05P4S14THSG varistor) close to the accessible point.

An open drain output is suitable to drive the **RESET\_N** input from an application processor, as the line is internally pulled up as illustrated in [Figure 32](#).

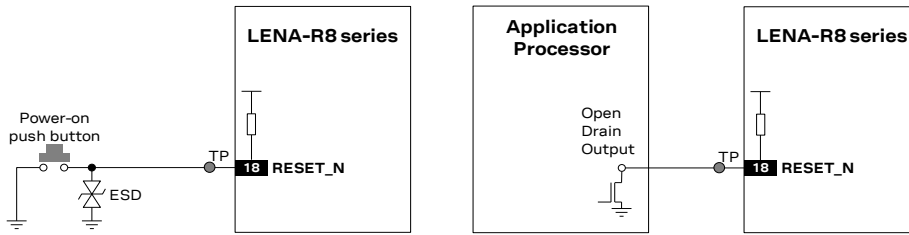

**Figure 32: RESET\_N application circuits using a push button and an open drain output of an application processor**

Reference	Description	Part number – manufacturer
ESD	Varistor for ESD protection	CT0402S14AHSG – EPCOS

**Table 19: Example of ESD protection component for the RESET\_N application circuit**

It is recommended to provide direct access on the application board by means of an accessible Test-Point directly connected to the **RESET\_N** pin, for diagnostic purpose.

### 2.3.2.2 Guidelines for RESET\_N layout design

The reset circuit (**RESET\_N**) requires careful layout due to the pin function: ensure that the voltage level is well defined during operation and no transient noise is coupled on this line, otherwise the module might detect a spurious reset request. It is recommended to keep the connection line to **RESET\_N** as short as possible.

## 2.4 Antenna interfaces

LENA-R8 series modules provide an RF interface for connecting the external cellular antenna: the **ANT** pin represents the RF input/output for LTE / 2G cellular RF signals transmission and reception.

LENA-R8001M10 modules provide also a GNSS RF interface for connecting the external GNSS antenna: the **ANT\_GNSS** pin represents the RF input for GNSS signals reception.

Both the **ANT** and the **ANT\_GNSS** pins have a nominal characteristic impedance of 50  $\Omega$  and have to be connected to the related RF antenna system through a 50  $\Omega$  transmission line to allow clean transmission / reception of RF signals.

### 2.4.1 General guidelines for antenna interfaces

The GNSS antenna RF interface is supported by LENA-R8001M10 modules only.

#### 2.4.1.1 Guidelines for ANT and ANT\_GNSS pins RF connection design

A clean transition between the **ANT** and **ANT\_GNSS** pads and the host application board PCB must be provided, implementing the following design-in guidelines for the layout of the application PCB close to the **ANT** and **ANT\_GNSS** pads:

- On a multilayer board, the whole layer stack below the RF connection should be free of digital lines.
- Increase GND keep-out (clearance) around the **ANT** and **ANT\_GNSS** pads, on the top layer of the application PCB, to at least 250  $\mu\text{m}$  up to adjacent pads metal definition, and up to 400  $\mu\text{m}$  on the area below the module, to reduce parasitic capacitance to GND, as illustrated in the left example picture of [Figure 33](#).

- Add GND keep-out (clearance) on the buried metal layer below **ANT** and **ANT\_GNSS** pads if the top-layer to buried layer dielectric thickness is below 200  $\mu\text{m}$ , to reduce parasitic capacitance to ground, as described in the right example of [Figure 33](#).

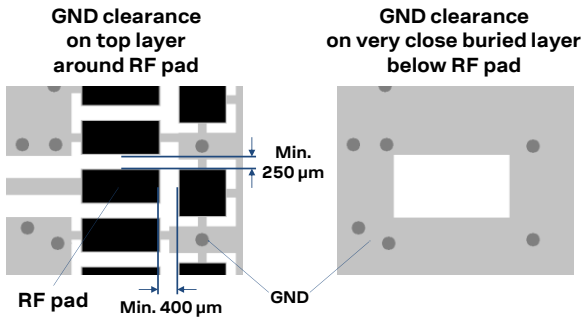

Figure 33: GND keep-out area on top layer around RF pad and on very close buried layer below RF pad (ANT / ANT\_GNSS)

### 2.4.1.2 Guidelines for RF transmission line design

Any RF transmission line, such as the ones from the **ANT** and **ANT\_GNSS** pads up to the related antenna connector or up to the related internal antenna pad, must be designed so that the characteristic impedance is as close as possible to 50  $\Omega$ .

RF transmission lines can be designed as a micro strip (consists of a conducting strip separated from a ground plane by a dielectric material) or a strip line (consists of a flat strip of metal which is sandwiched between two parallel ground planes within a dielectric material). The micro strip, implemented as a coplanar waveguide, is the most common configuration for printed circuit boards.

[Figure 34](#) and [Figure 35](#) provide two examples of suitable 50  $\Omega$  coplanar waveguide designs. The first example of RF transmission line can be implemented in case of 4-layer PCB stack-up herein described, and the second example of RF transmission line can be implemented in case of 6-layer PCB stack-up herein described.

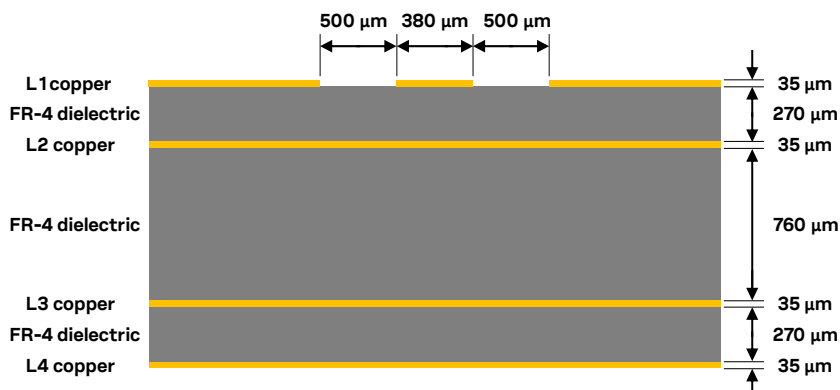

Figure 34: Example of 50  $\Omega$  coplanar waveguide transmission line design for the described 4-layer board layout

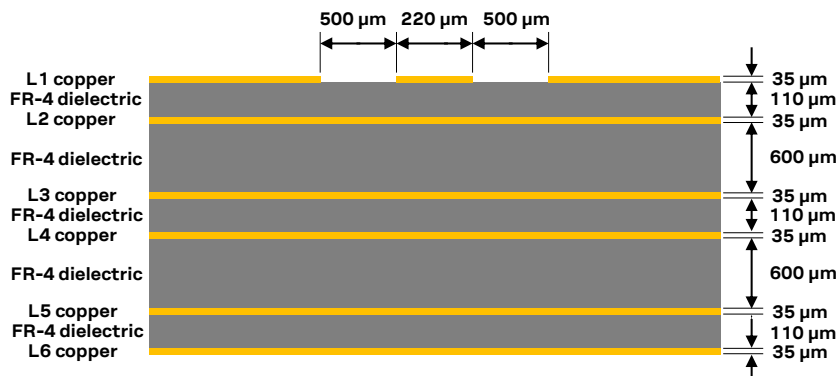

Figure 35: Example of 50  $\Omega$  coplanar waveguide transmission line design for the described 6-layer board layout

If the two examples do not match the application PCB layout, the 50  $\Omega$  characteristic impedance calculation can be made using the HFSS commercial finite element method solver for electromagnetic structures from Ansys Corporation, or using freeware tools like Avago / Broadcom AppCAD (<https://www.broadcom.com/appcad>), taking care of the approximation formulas used by the tools for the impedance computation.

To achieve a 50  $\Omega$  characteristic impedance, the width of the transmission line must be chosen depending on:

- The thickness of the transmission line itself (e.g., 35  $\mu\text{m}$  in the examples of the [Figure 34](#) and the [Figure 35](#))
- the thickness of the dielectric material between the top layer (where the transmission line is routed) and the inner closer layer implementing the ground plane (e.g., 270  $\mu\text{m}$  in [Figure 34](#), 1510  $\mu\text{m}$  in [Figure 35](#))
- the dielectric constant of the dielectric material (e.g. dielectric constant of the FR-4 dielectric material in [Figure 34](#) and [Figure 35](#))
- the gap from the transmission line to the adjacent ground plane on the same layer of the transmission line (e.g. 500  $\mu\text{m}$  in [Figure 34](#) and [Figure 35](#))

If the distance between the transmission line and the adjacent GND area (on the same layer) does not exceed 5 times the track width of the micro strip, use the “Coplanar Waveguide” model for the 50  $\Omega$  calculation.

Additionally, to the 50  $\Omega$  impedance, the following guidelines are recommended for the transmission line design:

- Minimize the transmission line length: the insertion loss should be minimized as much as possible, in the order of a few tenths of a dB.
- Add GND keep-out (i.e. clearance, a void area) on buried metal layers below any pad of component present on the RF transmission line, if top-layer to buried layer dielectric thickness is below 200  $\mu\text{m}$ , to reduce parasitic capacitance to ground.
- The transmission line width and spacing to GND must be uniform and routed as smoothly as possible: avoid abrupt changes of width and spacing to GND.
- Add GND vias around transmission line, as described in [Figure 36](#).
- Ensure solid metal connection of the adjacent metal layer on the PCB stack-up to the main ground layer, providing enough on the adjacent metal layer, as described in [Figure 36](#).
- Route RF transmission lines far from any noise source (as switching supplies and digital lines) and from any sensitive circuit (as analog audio lines).
- Avoid stubs on the transmission line.
- Avoid signal routing in parallel to the transmission line or crossing the transmission line on buried metal layer.
- Do not route the microstrip line below discrete components or other mechanics placed on the top layer.

Two examples of a suitable RF circuit design for **ANT** pin are illustrated in [Figure 36](#), where the cellular antenna detection circuit is not implemented (if the cellular antenna detection function is required by the application, follow the guidelines for circuit and layout implementation detailed in section [2.4.5](#)):

- In the first example shown on the left, the **ANT** pin is directly connected to an SMA connector by means of a suitable 50  $\Omega$  transmission line, designed with the appropriate layout.
- In the second example shown on the right, the **ANT** pin is connected to an SMA connector by means of a suitable 50  $\Omega$  transmission line, designed with the appropriate layout, with an additional high pass filter to improve the ESD immunity at the antenna port. (The filter consists of a suitable series capacitor and shunt inductor, for example the Murata GRM1555C1H150JB01 15 pF capacitor and the Murata LQG15HN39NJ02 39 nH inductor with SRF  $\sim$ 1 GHz.).

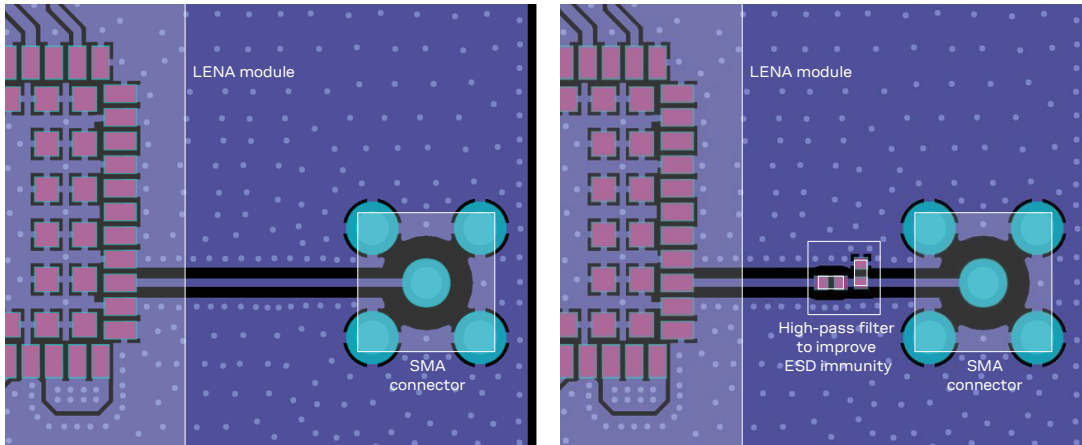

Figure 36: Example of circuit and layout for ANT RF circuits on the application board

### 2.4.1.3 Guidelines for RF termination design

RF terminations must provide a characteristic impedance of  $50\ \Omega$  as well as the RF transmission lines up to the RF terminations themselves, to match the characteristic impedance of the **ANT** and **ANT\_GNSS** ports of the modules.

However, real antennas do not have a perfect  $50\ \Omega$  load on all the supported frequency bands. Therefore, to reduce as much as possible any performance degradation due to antennas mismatch, the RF terminations must provide optimal return loss (or VSWR) figure over all the operating frequencies, as summarized in [Table 6](#).

If external antennas are used, the antenna connectors represent the RF termination on the PCB:

- Use suitable  $50\ \Omega$  connectors providing proper PCB-to-RF-cable transition.
- Strictly follow the connector manufacturer's recommended layout, for example:
  - SMA Pin-Through-Hole connectors require GND keep-out (i.e. clearance, a void area) on all the layers around the central pin up to annular pads of the four GND posts, as shown in [Figure 36](#).
  - U.FL surface mounted connectors require no conductive traces (i.e. clearance, a void area) in the area below the connector between the GND land pads, as illustrated in [Figure 37](#)

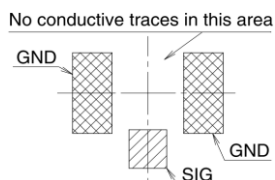

Figure 37: U.FL surface mounted connector mounting pattern layout

- Cut out the GND layer under RF connectors and close to buried vias, in order to remove stray capacitance and thus keep the RF line  $50\ \Omega$ , e.g. the active pad of U.FL connectors needs to have a GND keep-out (i.e. clearance, a void area) at least on the first inner layer to reduce parasitic capacitance to ground.

If integrated antennas are used, the RF terminations are represented by the integrated antennas themselves. The following guidelines should be followed:

- Use antennas designed by an antenna manufacturer, providing the best possible return loss (or VSWR).
- Provide a ground plane large enough according to the relative integrated antenna requirements. The ground plane of the application PCB can be reduced to a minimum size that must be similar to one quarter of a wavelength of the minimum frequency that must be radiated. As a numerical example,

$$\text{Frequency} = 617\ \text{MHz} \rightarrow \text{Wavelength} \cong 48\ \text{cm} \rightarrow \text{Minimum GND plane size} \cong 12\ \text{cm}$$

- It is highly recommended to strictly follow the detailed and specific guidelines provided by the antenna manufacturer regarding correct installation and deployment of the antenna system, including PCB layout and matching circuitry.
- Further to the custom PCB and product restrictions, antennas may require a tuning to comply with all the applicable required certification schemes. It is recommended to consult the antenna manufacturer for the design-in guidelines for the antenna matching relative to the custom application.

Additionally, these recommendations regarding the antenna system placement must be followed:

- Do not place antennas in a closed metal case.
- Do not place the antennas near the end user since the emitted radiation in human tissue is limited by regulatory requirements.
- Place the antennas as far as possible from VCC supply line and related parts (see also [Figure 29](#)), from high-speed digital lines (as USB) and from any possible noise source.
- Place the antennas far from sensitive analog systems or employ countermeasures to reduce EMC issues.
- Take care of interaction between co-located RF systems since the cellular transmitted power may interact or affect the performance of companion systems as a GNSS receiver (see section [2.4.4](#) for further details and design-in guidelines regarding Cellular / GNSS RF coexistence).

## 2.4.2 Cellular antenna RF interface (ANT)

### 2.4.2.1 General guidelines for antenna selection and design

The antenna is the most critical component to be evaluated. Designers must take care of the antennas from all perspectives at the very start of the design phase when the physical dimensions of the application board are under analysis/decision, since the RF compliance of the device integrating LENA-R8 series modules with all the applicable required certification schemes depends on the antenna radiating performance.

Cellular antennas are typically available in the types of linear monopole or PCB antennas such as patches or ceramic SMT elements.

- External antennas (e.g., linear monopole)
  - External antennas basically do not imply a physical restriction to the design of the PCB where the LENA-R8 series module is mounted.
  - The radiation performance mainly depends on the antennas. It is required to select antennas with optimal radiating performance in the operating bands.
  - RF cables should be carefully selected to have minimum insertion losses. Additional insertion loss will be introduced by low quality or long cable. Large insertion loss reduces both transmit and receive radiation performance.
  - A high quality 50  $\Omega$  RF connector provides proper PCB-to-RF-cable transition. It is recommended to strictly follow the layout and cable termination guidelines provided by the connector manufacturer.
  - If antenna detection functionality is required, select an antenna assembly with a proper built-in diagnostic circuit with a resistor connected to ground: see guidelines in section [2.4.5](#).
- Integrated antennas (e.g., patch-like antennas):
  - Internal integrated antennas imply a physical restriction to the design of the PCB: integrated antenna excites RF currents on its counterpoise, typically the PCB ground plane of the device that becomes part of the antenna: its dimension defines the minimum frequency that can be radiated. Thus, the ground plane can be reduced down to a minimum size that should be similar to the quarter of the wavelength of the minimum frequency that must be radiated, given that the orientation of the ground plane relative to the antenna element must be considered.

As a numerical example, physical restriction to the PCB design can be considered as following:

Frequency = 617 MHz → Wavelength  $\cong$  48 cm → Minimum GND plane size  $\cong$  12 cm

The isolation between the primary and the secondary antennas must be as high as possible and the correlation between the 3D radiation patterns of the two antennas must be as low as possible. In general, a separation of at least a quarter wavelength between the two antennas is required to achieve a good isolation and low pattern correlation.

- Radiation performance depends on the whole PCB and antenna system design, including product mechanical design and usage. Antennas should be selected with optimal radiating performance in the operating bands according to the mechanical specifications of the PCB and the whole product.
- It is recommended to select a pair of custom antennas designed by an antennas' manufacturer if the required ground plane dimensions are very small (as less than 6.5 cm long and 4 cm wide). The antenna design process should begin at the start of the whole product design process.
- It is highly recommended to strictly follow the detailed and specific guidelines provided by the antenna manufacturer regarding correct installation and deployment of the antenna system, including PCB layout and matching circuitry.
- Further to the custom PCB and product restrictions, antennas may require tuning to obtain the required performance for compliance with all the applicable required certification schemes.

 It is recommended to consult the antenna manufacturer for the design-in guidelines for antenna matching relative to the custom application.

In both cases, independently of external or internal antennas, these recommendations should be observed:

- Select antennas providing optimal return loss / VSWR / efficiency figure over all the operating frequencies.
- Select an antenna providing the worst possible return loss / VSWR / efficiency figure in the GNSS frequency band, to optimize the RF coexistence between the cellular and the GNSS systems (see section 2.4.4 for further details and guidelines regarding Cellular / GNSS RF coexistence).
- Select antennas providing appropriate gain figure (i.e. combined antenna directivity and efficiency figure) so that the electromagnetic field radiation intensity do not exceed the regulatory limits specified in related countries (see the FCC United States notice reported in section 4.2.2, the ISED Canada notice reported in section 4.3.1, the RED Europe notice reported in section 4.4).

### 2.4.2.2 Examples of cellular antennas

This section contains example antennas that satisfy the aforementioned requirements. There are numerous other part numbers and manufacturers, many offering customized solutions.

Table 20 lists some examples of internal on-board surface-mount antennas.

Manufacturer	Part number	Product name	Description
Taoglas	PA.760.A	WarriorX	Wideband LTE SMD antenna 600..6000 MHz 40.0 x 5.0 x 6.0 mm
Taoglas	PCS.26.A	Havok	LTE SMD dielectric antenna 617..960 MHz, 1710..2690 MHz 54.6 x 13.0 x 3.0 mm
Taoglas	PCS.66.A	Reach	Wideband LTE SMD antenna 600..6000 MHz 32.0 x 25.0 x 1.6 mm
Taoglas	PCS.06.A	Havok	GSM / WCDMA / LTE SMD Antenna 698..960 MHz, 1710..2170 MHz, 2500..2690 MHz 42.0 x 10.0 x 3.0 mm

Manufacturer	Part number	Product name	Description
Antenova	SR4L002	Lucida	GSM / WCDMA / LTE SMD Antenna 698..960 MHz, 1710..2170 MHz, 2300..2400 MHz, 2490..2690 MHz 35.0 x 8.5 x 3.2 mm
KYOCERA AVX	P822601 / P822602		GSM / WCDMA / LTE SMD antenna 698..960 MHz, 1710..2170 MHz, 2490..2700 MHz 50.0 x 8.0 x 3.2 mm
KYOCERA AVX	1002436		GSM / WCDMA / LTE vertical mount antenna 698..960 MHz, 1710..2700 MHz 50.6 x 19.6 x 1.6 mm
AMOTECH	AMMAL004, AMMAL008		GSM / WCDMA / LTE SMD Antenna, AEC-Q200 699..960 MHz, 1710..2690 MHz 35.0 x 9.0 x 3.2 mm
AMOTECH	AMMAL021, AMMAL022		GSM / WCDMA / LTE SMD Antenna, AEC-Q200 699..960 MHz, 1710..2690 MHz 39.0 x 9.0 x 3.2 mm
Ignion	NN03-310	TRIO mXTEND™	GSM / WCDMA / LTE SMD antenna 698..8000 MHz 30.0 x 3.0 x 1.0 mm
PulseLarsen Antennas	W3796	Domino	GSM / WCDMA / LTE SMD antenna 698..960 MHz, 1427..1661 MHz, 1695..2200 MHz, 2300..2700 MHz 42.0 x 10.0 x 3.0 mm
TE Connectivity	2118310-1		GSM / WCDMA / LTE vertical mount antenna 698..960 MHz, 1710..2170 MHz, 2300..2700 MHz 74.0 x 10.6 x 1.6 mm
Molex	1462000001		GSM / WCDMA / LTE SMD antenna 698..960 MHz, 1700..2700 MHz 40.0 x 5.0 x 5.0 mm
2J Antennas	2JE71		Ultra-wideband 5GNR/LTE surface-mount fiberglass antenna 617..960 MHz, 1427..2690 MHz, 3300..5000 MHz, 5150..5925 MHz 40.0 x 8.0 x 3.0 mm
2J Antennas	2JE38		Wideband cellular/LTE surface-mount fiberglass antenna 698..960 MHz, 1710..2170 MHz, 2500..2700 MHz 40.0 x 7.0 x 3.0 mm

**Table 20: Examples of internal surface-mount antennas**

[Table 21](#) lists examples of internal off-board PCB-type antennas with cable and connector.

Manufacturer	Part number	Product name	Description
Taoglas	FXUB63		GSM / WCDMA / LTE Antenna on flexible PCB with cable and U.FL 698..960 MHz, 1575.42 MHz, 1710..2170 MHz, 2400..2690 MHz 96.0 x 21.0 mm
Taoglas	FXUB66	Maximus	GSM / WCDMA / LTE Antenna on flexible PCB with cable and U.FL 600..6000 MHz 120.2 x 50.4 mm
Antenova	SRFL061	Lutosa	Flexible 5G / LTE antenna with cable and connector 617..960 MHz, 1420..1520 MHz, 1710..2200 MHz, 2300..2400 MHz, 2500..2690 MHz, 3300..3800 MHz 95.0 x 15.0 x 0.15 mm

Manufacturer	Part number	Product name	Description
Antenova	SRFL029	Moseni	Flexible cellular antenna with cable and connector 698..798 MHz, 824..960 MHz, 1710..2170 MHz, 2300..2400 MHz, 2500..2690 MHz 110.0 x 20.0 x 0.15 mm
KYOCERA AVX	1002289		GSM / WCDMA / LTE Antenna on flexible PCB with cable and U.FL 698..960 MHz, 1710..2700 MHz 50.0 x 8.0 x 3.2 mm
EAD	FSQS35241-UF-10	SQ7	GSM / WCDMA / LTE Antenna on PCB with cable and U.FL 690..960 MHz, 1710..2170 MHz, 2500..2700 MHz 110.0 x 21.0 mm
AMOTECH	AMMAL024		GSM / LTE Flexible PCB antenna with coaxial cable and connector 617..5000 MHz 120.0 x 30.0 mm
AMOTECH	AMMAL030U200		GSM / LTE Flexible PCB antenna with coaxial cable and connector 699..960 MHz, 1427..3800 MHz 43.0 x 43.0 mm
2J Antennas	2JF0683P		5G NR flexible polymer adhesive mount ultra-wideband antenna 617..960 MHz, 1427..2690 MHz, 3300..5000 MHz, 5150..5925 MHz 90.0 x 14.0 x 0.2 mm
2J Antennas	2JF0224P		Cellular/LTE flexible polymer adhesive mount wideband antenna 698..960 MHz, 1710..2170 MHz, 2500..2700 MHz 40.0 x 7.0 x 0.15 mm

**Table 21: Examples of internal antennas with cable and connector**

Table 22 lists some examples of external antennas.

Manufacturer	Part number	Product name	Description
Taoglas	GSA.8835.A.101111	Phoenix II	Wideband adhesive-mount antenna with cable and SMA(M) 600..6000 MHz 105 x 30 x 7.9 mm
Taoglas	GSA.8842.A.105111		Wideband I-Bar adhesive antenna with cable and SMA(M) 617..960 MHz, 1710..2700 MHz, 4900..5850 MHz 176.5 x 59.2 x 13.6 mm
Taoglas	GSA.8827.A.101111	Phoenix	Wideband adhesive mount antenna with cable and SMA(M) 698..960 MHz, 1575.42 MHz, 1710..2700 MHz 105 x 30 x 7.7 mm
Taoglas	TG.55.8113		LTE terminal mount monopole antenna with 90° hinged SMA(M) 617..960 MHz, 1427..2170 MHz, 2300..2690 MHz 172.0 x 23.88 x 13 mm
Taoglas	TG.35.8113	Apex II	Wideband LTE dipole terminal antenna hinged SMA(M) 617..1200 MHz, 1710..2700 MHz, 4900..5900 MHz 224 x 58 x 13 mm

Manufacturer	Part number	Product name	Description
AMOTECH	ACA556022-S0-A1		Low-profile, screw-type LTE/Sub6G antenna, Waterproof IP67 699..960 MHz, 1427..3800 MHz 55.0 x 60.0 x 22.0 mm
AMOTECH	ACA556022-S0-A2		Low-profile, adhesive-type LTE/Sub6G antenna, Waterproof IP67 699..960 MHz, 1427..3800 MHz 55.0 x 60.0 x 22.0 mm
AMOTECH	ACAD6623-S0-A1		Low-profile, roof-mount LTE/Sub6G antenna, Waterproof IP67 699..960 MHz, 1427..3800 MHz 23.0 x Ø 60.0 mm
KYOCERA AVX	X1005246		Adhesive-mount LTE external antenna 698..960 MHz, 1710..2170 MHz, 2300..2690 MHz, 1710..2700 MHz 105.1 x 30.1 x 6.7 mm
Laird Tech.	OC69271-FNM		Pole-mount antenna with N-type(M) 698..960 MHz, 1710..2690 MHz 248 x Ø 24.5 mm
Laird Tech.	CMD69273-30NM		Ceiling-mount MIMO antenna with cables & N-type(M) 698..960 MHz, 1710..2700 MHz 43.5 x Ø 218.7 mm
Pulse Electronics	WA700/2700SMA		Clip-mount MIMO antenna with cables and SMA(M) 698..960 MHz, 1710..2700 MHz 149 x 127 x 5.1 mm
2J Antennas	2JW1483		Connector-mount ultra-wideband antenna, waterproof: IP67, IP69 617..960 MHz, 1525..2690 MHz, 3300..3800 MHz 192 x 20 x 18 mm

Table 22: Examples of external antennas

## 2.4.3 GNSS antenna RF interface (ANT\_GNSS)



LENA-R8001 modules do not include a GNSS receiver: GNSS antenna interface is not available.

The antenna and its placement are critical system factors for accurate GNSS reception. Use of a ground plane will minimize the effects of ground reflections and enhance the antenna efficiency. A good allowance for ground plane size is typically in the area of 50 x 50 to 70 x 70 mm<sup>2</sup>. The smaller the electrical size of the plane, the narrower the reachable bandwidth and the lower the radiation efficiency. Exercise care with rover vehicles that emit RF energy from motors etc. as interference may extend into the GNSS band and couple into the GNSS antenna suppressing the wanted signal. For more details about GNSS antennas, see also the u-blox GNSS antennas application note [6].

Since LENA-R8001M10 modules already include an internal SAW filter, followed by an additional LNA, followed by another SAW filter before the u-blox GNSS chipset (as illustrated in Figure 2), they are optimized to work with passive or active antennas without requiring additional external circuitry.

### 2.4.3.1 Guidelines for applications with a passive antenna

If a GNSS passive antenna with high gain and good sky view is used, together with a short 50 Ω line between antenna and receiver, and no jamming sources affect the GNSS passive antenna, the circuit illustrated in Figure 38 can be used. This provides the minimum BoM cost and minimum board space.

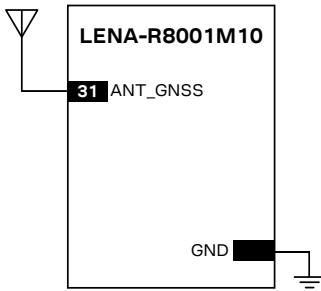

**Figure 38: Minimum circuit with GNSS passive antenna**

If the connection between the module and antenna incurs additional losses (e.g. antenna placed far away from the module, small ground plane for a patch antenna) or improved jamming immunity is needed due to strong out-of-band jammers close to the GNSS antenna (e.g. the cellular antenna is close to the GNSS antenna), consider adding an external SAW filter (see [Table 23](#) for possible suitable examples) close to the GNSS passive antenna, followed by an external LNA (see [Table 24](#) for possible suitable examples), as illustrated in [Figure 39](#), provided that LENA-R8001M10 modules already include an internal SAW filter, followed by an additional LNA, followed by another SAW filter before the u-blox GNSS chipset (as illustrated in [Figure 2](#)), so that additional external SAW and LNA are not required for most of the applications (see section [2.4.4](#) for further details and design-in guidelines regarding Cellular / GNSS RF coexistence).

-  An external LNA with related external SAW filter are only required if the GNSS antenna is far away (more than 10 cm) from the GNSS RF input of the module. In that case, the SAW and the LNA must be placed close to the passive antenna.

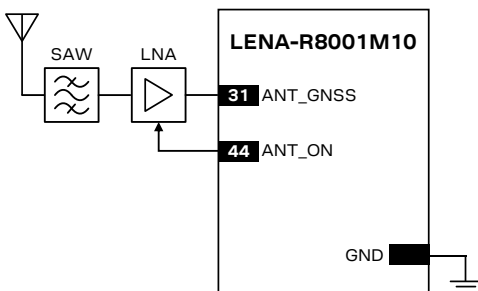

**Figure 39: Typical circuit for GNSS passive antenna placed far away from the module**

The external LNA can be selected to deliver the performance needed by the application in terms of:

- Noise figure (sensitivity)
- Selectivity and linearity (robustness against jamming)
- Robustness against RF power

Depending on the characteristics of the supply source (DC/DC regulator, linear LDO regulator or other) used to supply the external LNA, make sure some good filtering is in place for the external LNA supply because of the noise on the external LNA supply line can affect the performance of the LNA itself: consider adding a proper series ferrite bead (see [Table 25](#) for possible suitable examples) and a proper decoupling capacitor to ground with Self-Resonant Frequency in the GNSS frequency range (as for example the 27 pF 0402 capacitor Murata GCM1555C1H270JA16) at the input of the external LNA supply line.

Note that the insertion loss of the filter directly affects the system noise figure and hence the system performance. The selected SAW filter has to provide low loss (no more than 1.5 dB) in the GNSS pass-band, beside providing large attenuation (more than 40 to 60 dB) in the out-of-band jammers' cellular frequency bands (see [Table 23](#) for suitable examples).

LENA-R8001M10 modules already include an internal SAW filter, followed by an additional LNA, followed by another SAW filter before the u-blox GNSS chipset (as illustrated in [Figure 2](#)). The addition of such external components should be carefully evaluated, especially in case the application power consumption should be minimized, since the LNA alone requires an additional supply current of typically 5 to 20 mA.

Moreover, the first LNA of the input chain will dominate the receiver noise performance, therefore its noise figure should be less than 2 dB. If the antenna is close to the receiver, then a good passive antenna (see [Table 26](#)) can be directly connected to the receiver with a short (a few cm) 50 Ω line. From a noise point of view, this design choice offers comparable performance as an active antenna with a long (~3 to 5m) cable attached to the application board by means of an SMA connector without the increased power consumption and BOM cost. If the goal is to protect the GNSS receiver in a noisy environment, then an additional external SAW filter may be required. If a degradation in the C/No of 2 to 3 dB (depending on the choice of the filter) is not acceptable for the application, then, to compensate for the filter losses and restore an adequate C/No level, an external LNA with good gain and low noise figure (see [Table 24](#)) is to be considered.

[Table 23](#) lists examples of SAW filters suitable for the GNSS RF input of the modules.

Manufacturer	Part number	Description
Murata	SAFFB1G56AC0F0A	GPS / SBAS / QZSS / GLONASS / Galileo / BeiDou RF band-pass SAW filter with high attenuation in Cellular frequency ranges
Murata	SAFFB1G56AC0F7F	GPS / SBAS / QZSS / GLONASS / Galileo / BeiDou RF band-pass SAW filter with high attenuation in Cellular frequency ranges

**Table 23: Examples of GNSS band-pass SAW filters**

[Table 24](#) lists examples of LNA suitable for the GNSS RF input of the modules.

Manufacturer	Part number	Comments
Maxim	MAX2659ELT+	Low noise figure, up to 10 dBm RF input power
JRC New Japan Radio	NJG1143UA2	Low noise figure, up to 15 dBm RF input power
NXP	BGU8006	Low noise figure, very small package size (WL-CSP)
Infineon	BGA524N6	Low noise figure, small package size

**Table 24: Examples of GNSS Low Noise Amplifiers**

[Table 25](#) lists examples of ferrite beads suitable for the supply line of an external GNSS LNA.

Manufacturer	Part number	Comments
Murata	BLM15HD102SN1	High impedance at 1.575 GHz
Murata	BLM15HD182SN1	High impedance at 1.575 GHz
TDK	MMZ1005F121E	High impedance at 1.575 GHz
TDK	MMZ1005A121E	High impedance at 1.575 GHz

**Table 25: Examples of ferrite beads for the supply line of external GNSS Low Noise Amplifiers**

[Table 26](#) lists examples of passive antennas suitable for the GNSS RF input of the modules.

Manufacturer	Part number	Product name	Description
Tallysman	TW3400P		Passive antenna GPS / SBAS / QZSS / GLONASS
Tallysman	TW3710P		Passive antenna GPS / SBAS / QZSS / GLONASS / Galileo / BeiDou
Taoglas	CGGBP.35.3.A.02		Ceramic patch antenna GPS / SBAS / QZSS / GLONASS / Galileo / BeiDou

Manufacturer	Part number	Product name	Description
Taoglas	CGGBP.18.4.A.02		Embedded patch antenna GPS / SBAS / QZSS / GLONASS / Galileo / BeiDou
Inpaq	PA1590MF6G		Patch antenna GPS / SBAS / QZSS / GLONASS
Yageo	ANT2525B00BT1516S		Ceramic patch antenna GPS / SBAS / QZSS / GLONASS
Antenova	SR4G008	Sinica	Ultra-low profile patch antenna GPS / SBAS / QZSS / GLONASS / Galileo / BeiDou
AMOTECH	A18-4T		Ceramic patch antenna GPS / SBAS / QZSS / GLONASS / BeiDou
AMOTECH	A25-4T		Ceramic patch antenna GPS / SBAS / QZSS / BeiDou

**Table 26: Examples of GNSS passive antennas**

### 2.4.3.2 Guidelines for applications with an active antenna

Active antennas offer higher gain and better overall performance compared with passive antennas (without additional external SAW filter and LNA). However, the integrated low-noise amplifier contributes an additional current of typically 5 to 20 mA to the system's power consumption budget.

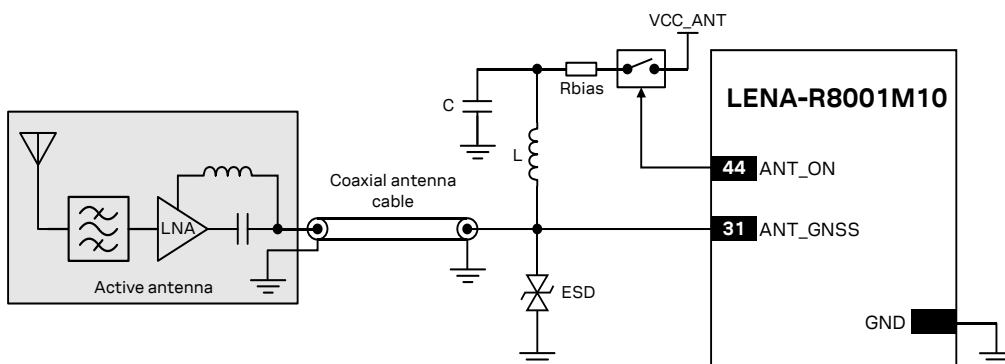

Active antennas for GNSS applications are usually powered through a DC bias on the RF cable. A simple bias-T, as shown in [Figure 40](#), can be used to add this DC current to the RF signal line. The inductance L is responsible for isolating the RF path from the DC path. It should be selected to offer high impedance ( $> 500 \Omega$ ) at L-band frequencies. A series current limiting resistor is required to prevent short circuits destroying the bias-t inductor.

To avoid damaging the bias-T series inductor in the case of a short circuit at the antenna connector, it is recommended to implement a proper over-current protection circuit, which may consist in a series resistor as in the example illustrated in [Figure 40](#). Component values are calculated according to the characteristics of the active antenna and the related supply circuit in use: the value of  $R_{bias}$  is calculated such that the maximum current capacity of the inductor L is never exceeded. Moreover,  $R_{bias}$  and C form a low pass filter to remove high frequency noise from the DC supply. Assuming  $VCC\_ANT=3.3 V$ , [Table 27](#) reports suggested components for the circuit in [Figure 40](#).

**Figure 40: Typical circuit with active antenna connected to GNSS RF interface, using an external supply**

Reference	Description	Part number - Manufacturer
L	120 nH wire-wound RF Inductor 0402 5% 110 mA	LQW15ANR12J00 - Murata
C	100 nF capacitor ceramic X7R 0402 10% 16 V	GCM155R71C104KA55 - Murata
Rbias	33 ohm resistor 0.5W	Various manufacturers

**Table 27: Example component values for active antenna biasing**

-  Refer to the antenna datasheet and/or manufacturer for proper values of the supply voltage VCC\_ANT, inductance L and capacitance C.
-  ESD sensitivity rating of the **ANT\_GNSS** RF input pin is 1 kV (HBM according to JESD22-A114). Higher protection level can be required if the line is externally accessible on the application board. Higher protection level can be achieved by mounting an ultra-low capacitance (i.e. < 1 pF) ESD protection (see [Table 28](#)) close to accessible point.

[Table 28](#) lists examples of ESD protection suitable for the GNSS RF input of the modules.

Manufacturer	Part number	Description
ON Semiconductor	ESD9R3.3ST5G	ESD protection diode with ultra-low capacitance (0.5 pF)
Infineon	ESD5V3U1U-02LS	ESD protection diode with ultra-low capacitance (0.4 pF)
Littelfuse	PESD0402-140	ESD protection diode with ultra-low capacitance (0.25 pF)

**Table 28: Examples of ultra-low capacitance ESD protections**

[Table 29](#) lists examples of GNSS active antennas to be used with the modules.

Manufacturer	Part number	Product name	Description
Tallysman	TW3400 – TW3402		Active antenna– 2.5 - 16 V GPS / SBAS / QZSS / GLONASS
Tallysman	TW3710 – TW3712		Active antenna, 2.5 – 16 V GPS / SBAS / QZSS / GLONASS / Galileo / BeiDou
Taoglas	AA.162.301111	Ulysses	Ultra-Low profile miniature antenna, 1.8 – 5.5V GPS / SBAS / QZSS / GLONASS / Galileo
Taoglas	MA310.A.LB.001		Magnet mount antenna, 1.8 – 5.5 V GPS / SBAS / QZSS / GLONASS
Taoglas	ASGGB254.A - ASGGB184.A		Active GNSS surface-mount patch antenna, 1.8 – 5.5 V GPS / SBAS / QZSS / GLONASS / BeiDou / Galileo
Taoglas	AGGBP.SL.25A – AGGBP.SL.18A		Active GNSS surface-mount patch antenna, 1.8 – 5.5 V GPS / SBAS / QZSS / GLONASS / BeiDou / Galileo
Abracon LLC	APAMP-110		Module RF antenna 5dBic SMA adhesive, 2.5 – 3.5 V GPS / SBAS / QZSS
TE Connectivity	2195768-1		Active antenna, 3.0 V typical GPS / SBAS / QZSS
AMOTECH	AGA151502-S0		Active antenna, 3.0 V typical GPS / SBAS / QZSS / GLONASS
AMOTECH	AGA393914-S0-A6		Active antenna, IP66, 5V typical GPS / SBAS / QZSS / GLONASS / BeiDou

**Table 29: Examples of GNSS active antennas**

## 2.4.4 Cellular and GNSS RF coexistence

### Overview

Desensitization or receiver blocking is a form of electromagnetic interference where a radio receiver is unable to detect a weak signal that it might otherwise be able to receive when there is no interference (see [Figure 41](#)). Good blocking performance is particularly important in the scenarios where several radios of various forms are used in close proximity to each other.

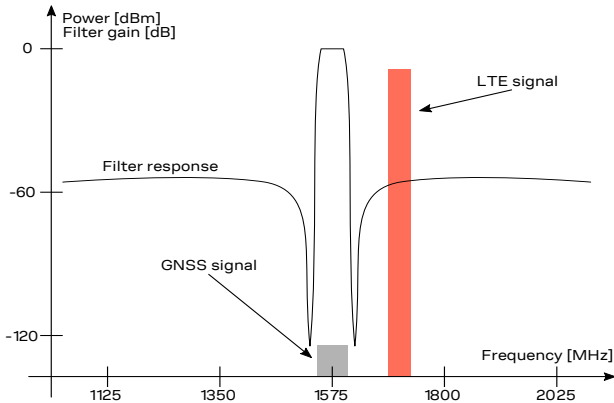

**Figure 41: Interference due to transmission in LTE B3, B4 and B66 low channels (1710 MHz) adjacent to GNSS frequency range (1561 to 1605 MHz).**

Jamming signals may come from in-band and out-of-band frequency sources. In-band jamming is caused by signals with frequencies falling within the GNSS frequency range, while the out-of-band jamming is caused by very strong signals adjacent to the GNSS frequency range so that part of the strong signal power may leak at the input of the GNSS receiver and/or block GNSS reception.

If not properly taken into consideration, in-band and out-of-band jamming signals may cause a reduction in the carrier-to-noise power density ratio (C/No) of the GNSS satellites.

### In-band interference

In-band interference signals are typically caused by harmonics from displays, switching converters, micro-controllers and bus systems. Countermeasures against in-band interference include:

- maintaining a good grounding concept in the design
- ensuring proper shielding of the different RF paths
- ensuring proper impedance matching of RF traces
- placing the GNSS antenna away from noise sources
- add a notch filter along the GNSS RF path, just after the antenna, at the frequency of the jammer (as for example illustrated in [Figure 42](#))

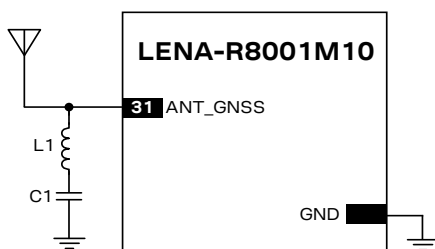

**Figure 42: Simple notch filter for improved in-band jamming immunity against a single jamming frequency**

With reference to [Figure 42](#), a simple notch filter can be realized by the series connection of an inductor and capacitor. Capacitor C1 and inductor L1 values are calculated according to the formula:

$$f = \frac{1}{2\pi\sqrt{C \cdot L}}$$

For example, a notch filter at ~787 MHz improves the GNSS immunity to LTE band 13 high channel. Suitable component nominal values are  $C1 = 3.3 \text{ pF}$  and  $L1 = 12 \text{ nH}$ , with tolerance less than or equal to 2 % to ensure adequate notch frequency accuracy.

### Out-of-band interference

Out-of-band interference is caused by signal frequencies that are different from the GNSS, the main sources being cellular, Wi-Fi, bluetooth transmitters, etc. For example, the lowest channels in LTE band 3, 4 and 66 may compromise the optimal reception of the GLONASS satellites. Again, the effect can be explained by comparing the LTE frequencies (band 3, 4 and 66 low channel transmission frequency is 1710 MHz) with the GLONASS operating band ( $1602 \text{ MHz} \pm 8 \text{ MHz}$ ). In this case the LTE signal is outside the useful GNSS band, but provided that the power received by the GNSS subsystem at 1710 MHz is high enough, blocking and leakage effects may appear reducing once again the C/No.

Countermeasures against out-of-band interference include:

- maintaining a good grounding concept in the design
- keeping the GNSS and cellular antennas more than the quarter-wavelength (of the minimum Tx frequency) away from each other. If for layout or size reasons this requirement cannot be met, then the antennas should be placed orthogonally to each other and/or on different side of the PCB.
- selecting a cellular antenna providing the worst possible return loss / VSWR / efficiency figure in the GNSS frequency band: the lower is the cellular antenna efficiency between 1575 MHz and 1610 MHz, the higher is the isolation between the cellular and the GNSS systems
- ensuring at least 15 – 20 dB isolation between antennas in the GNSS band by implementing the most suitable placement for the antennas, considering in particular the related radiation diagrams of the antennas: better isolation results from antenna patterns with radiation lobes in different directions considering the GNSS frequency band.
- adding a GNSS pass-band SAW filter along the GNSS RF line, providing very large attenuation in the cellular frequency bands (see [Table 23](#) for possible suitable examples). It has to be noted that, LENA-R8001M10 modules already include an internal SAW filter, followed by an additional LNA, followed by another SAW filter before the u-blox GNSS chipset (as illustrated in [Figure 2](#)): the addition of an external filter along the GNSS RF line has to be considered only if the conditions above cannot be met.

### Additional countermeasures

If all above countermeasures cannot be implemented, adding a GNSS stop-band SAW filter along the cellular RF line may be considered. The filter shall provide very low attenuation in the cellular frequency bands (see [Table 30](#) for possible suitable examples). Note that the addition of an external filter along the cellular RF line has to be carefully evaluated, as the additional insertion loss of such filter may affect the cellular TRP and/or TIS RF figures.

[Table 30](#) lists examples of GNSS band-stop SAW filters that may be considered for the cellular RF input/output in case enough isolation between the cellular and the GNSS RF systems cannot be provided by proper selection and placement of the antennas beside other proper RF design solutions.

Manufacturer	Part number	Description
Qualcomm RF360	B8636	GNSS (L1) SAW extractor filter 1.7 x 1.3 mm
Qualcomm RF360	B8666	GNSS (L1) SAW extractor filter 1.5 x 1.1 mm
Murata	SADAC1G56AB0E0A	GNSS (L1) SAW extractor filter 1.5 x 1.1 mm
TST	TE0123A	GPS (1575.42 MHz) SAW band-stop filter 3.0 x 3.0 mm

**Table 30: Examples of GNSS band-stop SAW filters**

## Additional considerations

As far as the RF Tx power is involved in the cellular / GNSS RF coexistence, it has to be noted that high-power transmission occurs very infrequently: typical values are in the range of -3 to 0 dBm (see the Tx Power distribution in the GSMA TS.09 [17]). Therefore, depending on the application, careful PCB layout, antenna selection and placement should be sufficient to ensure accurate GNSS reception.

For an example of vehicle tracking application in a small form factor featuring cellular and short-range connectivity alongside a multi-constellation GNSS receiver, with successful RF coexistence between the systems, refer to the u-blox B36 vehicle tracking blueprint [19]. The distance between the cellular and GNSS antennas for the u-blox B36 blueprint is annotated in Figure 43.

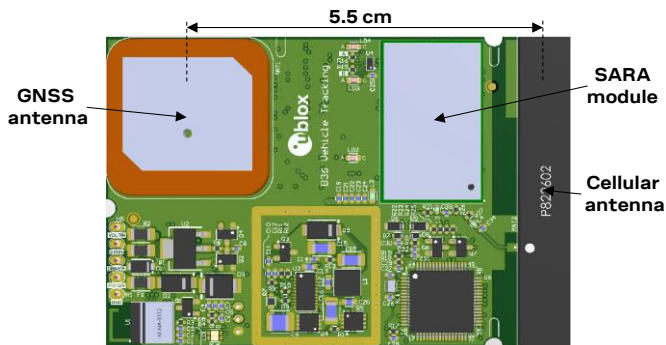

Figure 43: PCB top rendering for the u-blox B36 blueprint with annotated distance between cellular and GNSS antennas

## 2.4.5 Cellular antenna detection interface (ANT\_DET)

### 2.4.5.1 Guidelines for ANT\_DET circuit design

Figure 44 / Table 31 describe the recommended schematic / components for the antenna detection circuit to be implemented on the application board to make available the optional cellular antenna detection functionality, in case the selected external antenna is equipped with the diagnostic circuit included in the antenna's assembly.

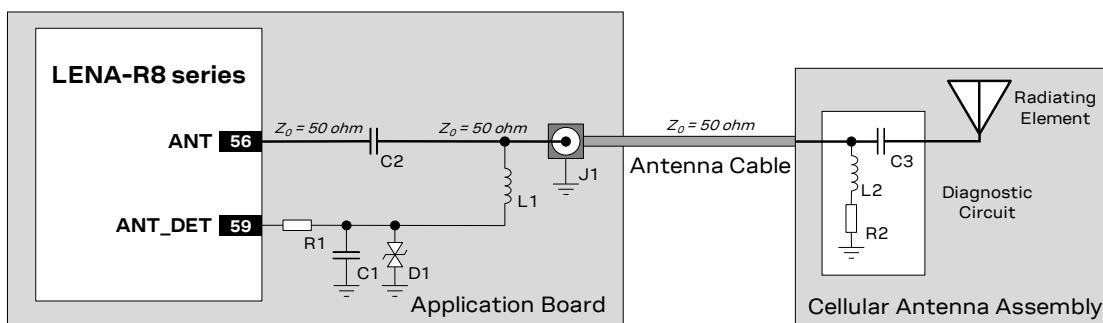

Figure 44: Suggested schematic for antenna detection circuit on application PCB and diagnostic circuit on antenna assembly

Reference	Description	Part number - manufacturer
C1	27 pF Capacitor Ceramic C0G 0402 5% 50 V	GRM1555C1H270J - Murata
C2	33 pF Capacitor Ceramic C0G 0402 5% 50 V	GRM1555C1H330J - Murata
D1	Very Low Capacitance ESD Protection	PESD0402-140 - Tyco Electronics
L1	68 nH Multilayer Inductor 0402 (SRF ~1 GHz)	LQG15HS68NJ02 - Murata
R1	10 k $\Omega$ Resistor 0402 1% 0.063 W	Various Manufacturers
J1	Connector 50 $\Omega$	Various Manufacturers
C3	22 pF Capacitor Ceramic C0G 0402 5% 25 V	GRM1555C1H220J - Murata
L2	68 nH Multilayer Inductor 0402 (SRF ~1 GHz)	LQG15HS68NJ02 - Murata
R2	15 k $\Omega$ Resistor for Diagnostic	Various Manufacturers

**Table 31: Example of parts for antenna detection circuit on application PCB and diagnostic circuit on antenna assembly**

The antenna detection circuit and diagnostic circuit suggested in [Figure 44](#) and [Table 31](#) are explained here:

- When antenna detection is forced by the AT+UANTR command, **ANT\_DET** generates a DC current measuring the resistance (R2) from the antenna connectors (J1) provided on the application board to GND.
- DC blocking capacitors are needed at the **ANT** pins (C2) and at the antenna radiating element (C3) to decouple the DC current generated by the **ANT\_DET** pin.
- Choke inductors with a Self-Resonance Frequency (SRF) in the range of 1 GHz are needed in series at the **ANT\_DET** pin (L1) and in series at the diagnostic resistor (L2), to avoid a reduction of the RF performance of the system, improving the RF isolation of the load resistor.
- Additional components (R1, C1 and D1 in [Figure 44](#)) are needed at the **ANT\_DET** pin as part of the antenna detection circuit and for further ESD protection improvement
- The **ANT** pin must be connected to the antenna connector by means of a transmission line with nominal characteristics impedance as close as possible to 50  $\Omega$ .

The DC impedance at the RF port for some antennas may be a DC open (e.g. linear monopole) or a DC short to reference GND (e.g. PIFA antenna). For those antennas, without the diagnostic circuit of [Figure 44](#), the measured DC resistance is always at the limits of the measurement range (respectively open or short), and there is no means to distinguish between a defect on the antenna path with similar characteristics (respectively: removal of linear antenna or RF cable shorted to GND for a PIFA antenna).

Furthermore, any other DC signal injected to the RF connection from an ANT connector to a radiating element will alter the measurement and produce invalid results for antenna detection.

-  It is recommended to use an antenna with a built-in diagnostic resistor in the range from 5 k $\Omega$  to 30 k $\Omega$  to assure good antenna detection functionality and avoid a reduction of module RF performance. The choke inductor should exhibit a parallel Self Resonance Frequency (SRF) in the range of 1 GHz to improve the RF isolation of load resistor.

For example:

Consider an antenna with a built-in DC load resistor of 15 k $\Omega$ . Using the +UANTR AT command, the module reports the resistance value evaluated from the antenna connector provided on the application board to GND:

- Reported values close to the used diagnostic resistor nominal value (i.e. values from 13 k $\Omega$  to 17 k $\Omega$  if a 15 k $\Omega$  diagnostic resistor is used) indicate that the antenna is properly connected.
- Values close to the measurement range maximum limit (approximately 50 k $\Omega$ ) or an open-circuit “over range” report (see the AT commands manual [\[2\]](#)) means that that the antenna is not connected or the RF cable is broken.

- Reported values below the measurement range minimum limit (1 k $\Omega$ ) highlights a short to GND at the antenna or along the RF cable.
- Measurement inside the valid measurement range and outside the expected range may indicate an improper connection, damaged antenna or wrong value of antenna load resistor for diagnostics.
- The reported value could differ from the real resistance value of the diagnostic resistor mounted inside the antenna assembly due to antenna cable length, antenna cable capacity or the measurement method used.

 If the antenna detection function is not required by the customer application, the **ANT\_DET** pin can be left unconnected and the **ANT** pin can be directly connected to the related antenna connector by a 50  $\Omega$  transmission line as described in [Figure 36](#).

### 2.4.5.2 Guidelines for ANT\_DET layout design

The recommended layout for the primary antenna detection circuit to be provided on the application board to achieve the primary antenna detection functionality, implementing the recommended schematic described in [Figure 44](#) and [Table 31](#), is explained here:

- The **ANT** pin must be connected to the antenna connector by a 50  $\Omega$  transmission line, implementing the design guidelines described in section [2.4.2](#) and the recommendations of the SMA connector manufacturer.
- DC blocking capacitor at **ANT** pin (C2) must be placed in series to the 50  $\Omega$  RF line.
- The **ANT\_DET** pin must be connected to the 50  $\Omega$  transmission line by means of a sense line.
- Choke inductors in series at the **ANT\_DET** pin (L1) must be placed so that one pad is on the 50  $\Omega$  transmission line and the other pad represents the start of the sense line to **ANT\_DET** pin.
- The additional components (R1, C1, D1) on the **ANT\_DET** line must be placed as ESD protection.

### 2.4.6 Cellular antenna dynamic tuning interface (RFCTRL1 / RFCTRL2)

 The cellular antenna dynamic tuner interface over **RFCTRL1 / RFCTRL2** pins is not supported.

## 2.5 Cellular SIM interface

### 2.5.1.1 Guidelines for SIM circuit design

#### Guidelines for SIM cards, SIM connectors and SIM chips selection

The ISO/IEC 7816, the ETSI TS 102 221 and the ETSI TS 102 671 specifications define the physical, electrical and functional characteristics of Universal Integrated Circuit Cards (UICC) which contains the Subscriber Identification Module (SIM) integrated circuit that securely stores all the information needed to identify and authenticate subscribers over the cellular network.

Removable UICC / SIM card contacts mapping is defined by ISO/IEC 7816 and ETSI TS 102 221 as follows:

- |   |  |
|---|--|
| • Contact C1 = VCC (Supply)             | → It must be connected to <b>VSIM</b>    |
| • Contact C2 = RST (Reset)              | → It must be connected to <b>SIM_RST</b> |
| • Contact C3 = CLK (Clock)              | → It must be connected to <b>SIM_CLK</b> |
| • Contact C4 = AUX1 (Auxiliary contact) | → It must be left not connected          |
| • Contact C5 = GND (Ground)             | → It must be connected to <b>GND</b>     |
| • Contact C6 = VPP/SWP (Other function) | → It can be left not connected           |
| • Contact C7 = I/O (Data input/output)  | → It must be connected to <b>SIM_IO</b>  |
| • Contact C8 = AUX2 (Auxiliary contact) | → It must be left not connected          |

A removable SIM card can have 6 contacts (C1, C2, C3, C5, C6, C7) or 8 contacts, also including the auxiliary contacts C4 and C8. Only 6 contacts are required and must be connected to the module SIM interface.

Removable SIM cards are suitable for applications requiring a change of SIM card during the product lifetime.

A SIM card holder can have 6 or 8 positions if a mechanical card presence detector is not provided, or it can have 6+2 or 8+2 positions if two additional pins relative to the normally-open mechanical switch integrated in the SIM connector for the mechanical card presence detection are provided. Select a SIM connector providing 6+2 or 8+2 positions if the optional SIM detection feature is required by the custom application, otherwise a connector without an integrated mechanical presence switch can be selected.

Solderable UICC / SIM chip contact mapping (M2M UICC Form Factor) is defined by ETSI TS 102 671 as:

- Case pin 8 = UICC contact C1 = VCC (Supply) → It must be connected to **VSIM**
- Case pin 7 = UICC contact C2 = RST (Reset) → It must be connected to **SIM\_RST**
- Case pin 6 = UICC contact C3 = CLK (Clock) → It must be connected to **SIM\_CLK**
- Case pin 5 = UICC contact C4 = AUX1 (Aux.contact) → It must be left not connected
- Case pin 1 = UICC contact C5 = GND (Ground) → It must be connected to **GND**
- Case pin 2 = UICC contact C6 = VPP/SWP (Other) → It can be left not connected
- Case pin 3 = UICC contact C7 = I/O (Data I/O) → It must be connected to **SIM\_IO**
- Case pin 4 = UICC contact C8 = AUX2 (Aux. contact) → It must be left not connected

A solderable SIM chip has 8 contacts and can also include the auxiliary contacts C4 and C8 for other uses, but only 6 contacts are required and must be connected to the module SIM card interface as described above.

Solderable SIM chips are suitable for M2M applications where it is not required to change the SIM once installed.

### Guidelines for single SIM card connection

A removable SIM card placed in a SIM card holder must be connected to the SIM card interface of LENA-R8 series modules as described in Figure 45, where the optional SIM detection feature is not implemented.

Follow these guidelines connecting the module to a SIM connector without SIM presence detection:

- Connect the UICC / SIM contacts C1 (VCC) to the **VSIM** pin of the module.
- Connect the UICC / SIM contact C7 (I/O) to the **SIM\_IO** pin of the module.
- Connect the UICC / SIM contact C3 (CLK) to the **SIM\_CLK** pin of the module.
- Connect the UICC / SIM contact C2 (RST) to the **SIM\_RST** pin of the module.
- Connect the UICC / SIM contact C5 (GND) to ground.
- Provide a 100 nF bypass capacitor (e.g. Murata GRM155R71C104K) at the SIM supply line (**VSIM**), close to the related pad of the SIM connector, to prevent digital noise.
- Provide a bypass capacitor of about 22 pF to 47 pF (e.g. Murata GRM1555C1H470J) on each SIM line (**VSIM**, **SIM\_CLK**, **SIM\_IO**, **SIM\_RST**), very close to each related pad of the SIM connector, to prevent RF coupling especially when the RF antenna is placed closer than 10 - 30 cm from the SIM card holder.
- Provide a low capacitance (i.e. less than 10 pF) ESD protection (e.g. Littelfuse PESD0402-140) on each externally accessible SIM line, close to each related pad of the SIM connector: the ESD sensitivity rating of the SIM interface pins is 1 kV (HBM), so that, according to the EMC/ESD requirements of the custom application, a higher protection level can be required if the lines are externally accessible on the application device.
- Limit the capacitance and series resistance on each signal of the SIM interface (**SIM\_CLK**, **SIM\_IO**, **SIM\_RST**) to match the SIM interface specifications requirements for the max allowed rise time.

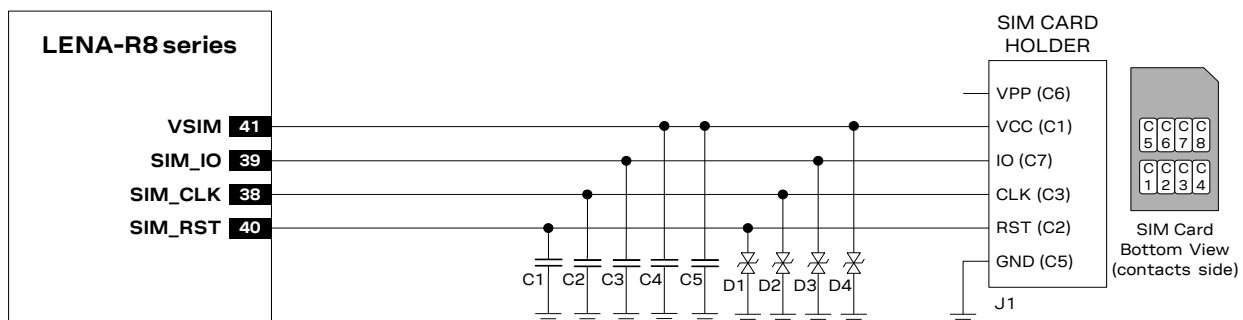

Figure 45: Application circuit for the connection to a single removable SIM card, with SIM detection not implemented

Reference	Description	Part number - manufacturer
C1, C2, C3, C4	47 pF Capacitor Ceramic C0G 0402 5% 50 V	GRM1555C1H470JA01 - Murata
C5	100 nF Capacitor Ceramic X7R 0402 10% 16 V	GRM155R71C104KA01 - Murata
D1, D2, D3, D4	Very Low Capacitance ESD Protection	PESD0402-140 - Littelfuse
J1	SIM Card Holder 6 positions, without card presence switch	Various Manufacturers, as C707 10M006 136 2 - Amphenol

Table 32: Example of components for the connection to a single removable SIM card, with SIM detection not implemented

### Guidelines for single SIM chip connection

A solderable SIM chip (M2M UICC Form Factor) must be connected the SIM card interface of LENA-R8 series modules as described in [Figure 46](#).

Follow these guidelines, connecting the module to a solderable SIM chip without SIM presence detection:

- Connect the UICC / SIM contacts C1 (VCC) to the **VSIM** pin of the module.
- Connect the UICC / SIM contact C7 (I/O) to the **SIM\_IO** pin of the module.
- Connect the UICC / SIM contact C3 (CLK) to the **SIM\_CLK** pin of the module.
- Connect the UICC / SIM contact C2 (RST) to the **SIM\_RST** pin of the module.
- Connect the UICC / SIM contact C5 (GND) to ground.
- Provide a 100 nF bypass capacitor (e.g. Murata GRM155R71C104K) at the SIM supply line (**VSIM**) close to the related pad of the SIM chip, to prevent digital noise.
- Provide a bypass capacitor of about 22 pF to 47 pF (e.g. Murata GRM1555C1H470J) on each SIM line (**VSIM**, **SIM\_CLK**, **SIM\_IO**, **SIM\_RST**), to prevent RF coupling especially in case the RF antenna is placed closer than 10 - 30 cm from the SIM.
- Limit the capacitance and series resistance on each signal of the SIM interface (**SIM\_CLK**, **SIM\_IO**, **SIM\_RST**) to match the SIM specifications requirements for the max allowed rise time.

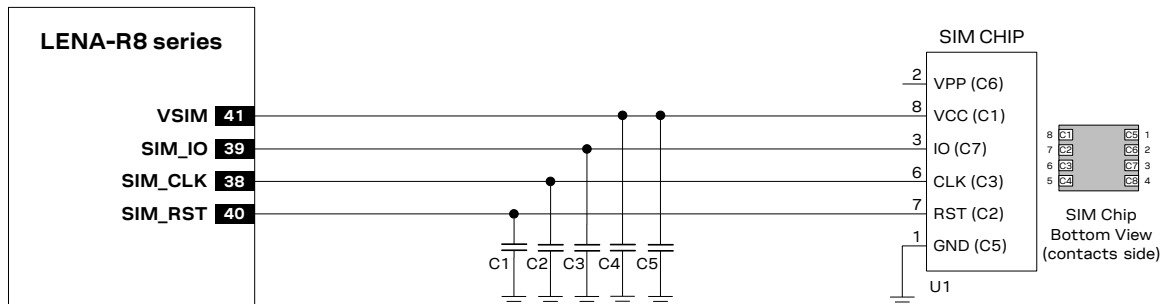

**Figure 46: Application circuit for the connection to a single solderable SIM chip, with SIM detection not implemented**

Reference	Description	Part number - manufacturer
C1, C2, C3, C4	47 pF Capacitor Ceramic C0G 0402 5% 50 V	GRM1555C1H470JA01 - Murata
C5	100 nF Capacitor Ceramic X7R 0402 10% 16 V	GRM155R71C104KA01 - Murata
U1	SIM chip (M2M UICC Form Factor)	Various Manufacturers

**Table 33: Example of components for the connection to a single solderable SIM chip, with SIM detection not implemented**

### Guidelines for dual SIM card / chip connection

Two SIM cards / chips can be connected to LENA-R8 series modules' SIM interface as in [Figure 47](#).

LENA-R8 series modules do not support the usage of two SIMs at the same time, but two SIMs can be populated on the application board, providing a proper switch to connect only the first or only the second SIM at a time to the SIM interface of the modules, as described in [Figure 47](#).

In the application circuit example represented in [Figure 47](#), the application processor will drive the SIM switch using its own GPIO to properly select the SIM that is used by the module, when the SIM interface of the module is disabled, as when the module cellular system is switched off.

The dual SIM connection circuit described in [Figure 47](#) can be implemented for SIM chips as well, providing proper connection between SIM switch and SIM chip as described in [Figure 46](#).

If it is required to switch between more than 2 SIM, a circuit like the one described in [Figure 47](#) can be implemented: for a 4 SIM circuit, using proper 4-throw switch instead of the suggested 2-throw switches.

Follow these guidelines connecting the module to two SIM connectors:

- Use a proper low on resistance (i.e. few ohms) and low on capacitance (i.e. few pF) 2-throw analog switch (e.g. Fairchild FSA2567) as SIM switch to ensure high-speed data transfer according to SIM requirements.
- Connect the contacts C1 (VCC) of the two UICC / SIM to the **VSIM** pin of the module by means of a proper 2-throw analog switch (e.g. Fairchild FSA2567).
- Connect the contact C7 (I/O) of the two UICC / SIM to the **SIM\_IO** pin of the module by means of a proper 2-throw analog switch (e.g. Fairchild FSA2567).
- Connect the contact C3 (CLK) of the two UICC / SIM to the **SIM\_CLK** pin of the module by means of a proper 2-throw analog switch (e.g. Fairchild FSA2567).
- Connect the contact C2 (RST) of the two UICC / SIM to the **SIM\_RST** pin of the module by means of a proper 2-throw analog switch (e.g. Fairchild FSA2567).
- Connect the contact C5 (GND) of the two UICC / SIM to ground.
- Provide a 100 nF bypass capacitor (e.g. Murata GRM155R71C104K) at the SIM supply line (**VSIM**), close to the related pad of the two SIM connectors, to prevent digital noise.
- Provide a bypass capacitor of about 22 pF to 47 pF (e.g. Murata GRM1555C1H470J) on each SIM line (**VSIM**, **SIM\_CLK**, **SIM\_IO**, **SIM\_RST**), very close to each related pad of the two SIM connectors, to prevent RF coupling especially in case the RF antenna is placed closer than 10 - 30 cm from the SIM card holders.
- Provide a very low capacitance (less than 10 pF) ESD protection (e.g. Littelfuse PESD0402-140) on each externally accessible SIM line, close to each related pad of the two SIM connectors, according to the EMC/ESD requirements of the custom application.
- Limit capacitance and series resistance on each SIM signal to match the SIM specifications (as for example, 1.0  $\mu$ s is the max allowed rise time on **SIM\_IO** and **SIM\_RST**).

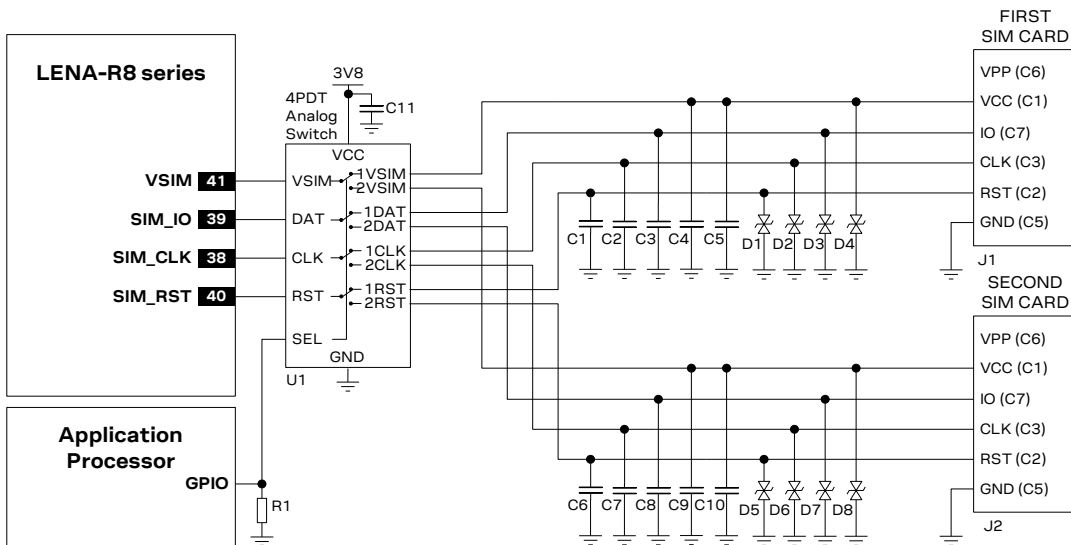

**Figure 47: Application circuit for the connection to two removable SIM cards, with SIM detection not implemented**

Reference	Description	Part number - manufacturer
C1 – C4, C6 – C9	33 pF Capacitor Ceramic C0G 0402 5% 25 V	GRM1555C1H330JZ01 - Murata
C5, C10, C11	100 nF Capacitor Ceramic X7R 0402 10% 16 V	GRM155R71C104KA01 - Murata
D1 – D8	Very Low Capacitance ESD Protection	PESD0402-140 - Littelfuse
R1	47 k $\Omega$ Resistor 0402 5% 0.1 W	Various Manufacturers
J1, J2	SIM Card Holder 6 positions, without card presence switch	Various Manufacturers, as C707 10M006 136 2 - Amphenol
U1	4PDT Analog Switch, with Low On-Capacitance and Low On-Resistance	FSA2567 - Fairchild Semiconductor

**Table 34: Example of components for the connection to two removable SIM cards, with SIM detection not implemented**

### 2.5.1.2 Guidelines for SIM layout design

The layout of the SIM card interface lines (**VSIM**, **SIM\_CLK**, **SIM\_IO**, **SIM\_RST**) may be critical if the SIM card is placed far away from the LENA-R8 series modules or in close proximity to the RF antenna: these two cases should be avoided or at least mitigated as described below.

In the first case, the long connection can cause the radiation of some harmonics of the digital data frequency as any other digital interface: keep the traces short and avoid coupling with RF line or sensitive analog inputs.

In the second case, the same harmonics can be picked up and create self-interference that can reduce the sensitivity of cellular receiver channels whose carrier frequency is coincidental with harmonic frequencies: placing the RF bypass capacitors suggested in [Figure 46](#) near the SIM connector will mitigate the problem.

In addition, since the SIM card is typically accessed by the end user, it can be subjected to ESD discharges: add adequate ESD protection as suggested in [Figure 46](#) to protect the module SIM pins near the SIM connector.

Limit the capacitance and series resistance on each SIM signal to match the SIM specifications: the connections should always be kept as short as possible.

Avoid coupling with any sensitive analog circuit, since the SIM signals can cause the radiation of some harmonics of the digital data frequency.

## 2.6 Cellular serial communication interfaces

### 2.6.1 Cellular UART interfaces

#### 2.6.1.1 Guidelines for UART circuit design

##### UART with full RS-232 functionality (using the complete V.24 link)

If RS-232 compatible signal levels are needed, two different external voltage translators can be used to provide full RS-232 (with all the signal lines part of the complete V.24 link) functionality: e.g. using the Texas Instruments SN74AVC8T245PW for the translation from 1.8 V to 3.3 V, and the Maxim MAX3237E for the translation from 3.3 V to RS-232 compatible signal level.

If a 1.8 V Application Processor (DTE) is used, and complete RS-232 function is required, the complete 1.8 V UART interface of the module (DCE) should be connected to a 1.8 V DTE, as in [Figure 48](#).

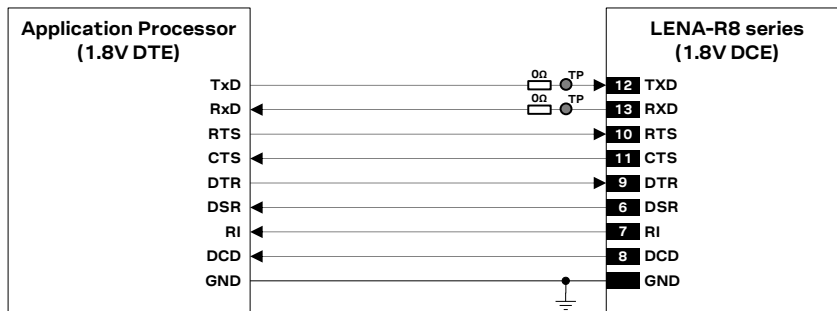

Figure 48: UART interface application circuit with complete V.24 link in DTE/DCE serial communication (1.8 V DTE)

If a 3.0 V Application Processor (DTE) is used, then it is recommended to connect the 1.8 V UART interface of the module (DCE) by means of appropriate unidirectional voltage translators using the module V\_INT output as a 1.8 V supply for the voltage translators on the module side, as in [Figure 49](#).

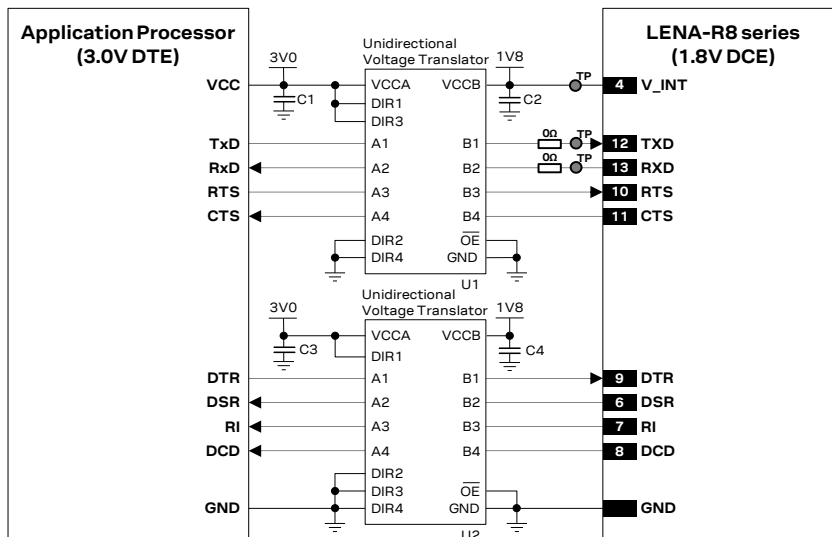

Figure 49: UART interface application circuit with complete V.24 link in DTE/DCE serial communication (3.0 V DTE)

Reference	Description	Part number - manufacturer
C1, C2, C3, C4	100 nF Capacitor Ceramic	Various Manufacturers
U1, U2	Unidirectional Voltage Translator	SN74AVC4T774 <sup>8</sup> - Texas Instruments

Table 35: Component for UART application circuit with complete V.24 link in DTE/DCE serial communication (3.0 V DTE)

<sup>8</sup> Voltage translator providing partial power down feature so that the 3 V supply can be ramped up before V\_INT 1.8 V supply

### UART with TXD, RXD, RTS and CTS lines only

If the functionality of the **DSR**, **DCD**, **RI** and **DTR** lines is not required, or the lines are not available:

- Connect the module **DTR** input to GND, since it may be useful to set **DTR** active if not specifically handled (see the AT commands manual [2], &D, S0, +CSGT, +CNMI AT commands)
- Leave the **DSR**, **DCD** and **RI** lines of the module floating

If RS-232 compatible signal levels are needed, the Maxim MAX13234E voltage level translator can be used. This chip translates voltage levels from 1.8 V (module side) to the RS-232 standard.

If a 1.8 V Application Processor is used, the circuit should be implemented as described in [Figure 50](#).

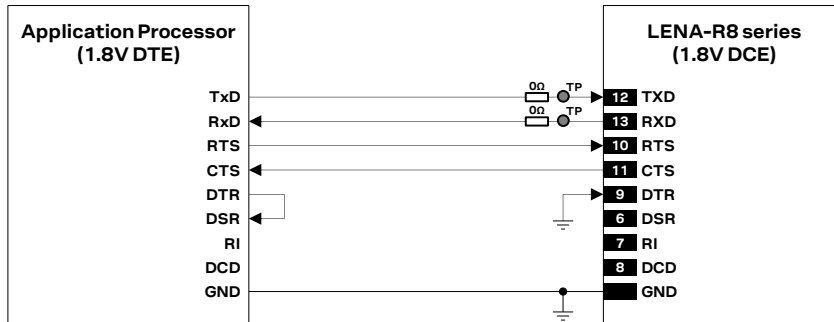

Figure 50: UART interface application circuit with partial V.24 link in the DTE/DCE serial communication (1.8 V DTE)

If a 3.0 V Application Processor (DTE) is used, then it is recommended to connect the 1.8 V UART interface of the module (DCE) by means of appropriate unidirectional voltage translators using the module **V\_INT** output as 1.8 V supply for the voltage translators on the module side, as described in [Figure 51](#).

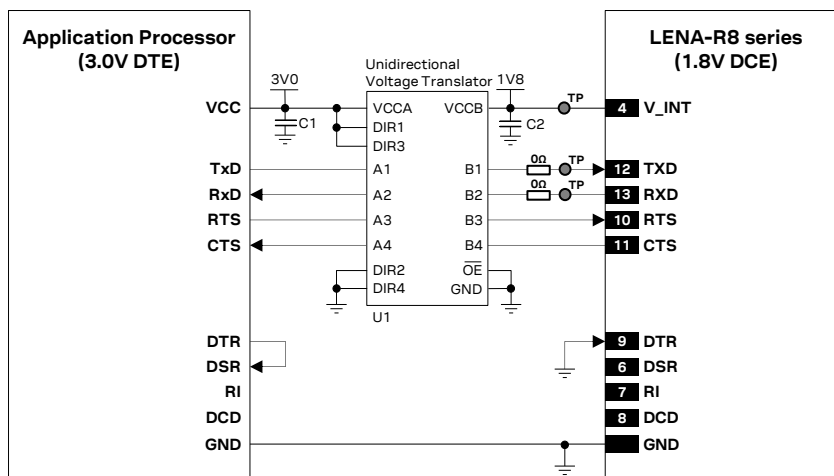

Figure 51: UART interface application circuit with partial V.24 link in DTE/DCE serial communication (3.0 V DTE)

Reference	Description	Part number - manufacturer
C1, C2	100 nF Capacitor Ceramic	Various Manufacturers
U1	Unidirectional Voltage Translator	SN74AVC4T774 <sup>10</sup> - Texas Instruments

Table 36: Parts for UART application circuit with partial V.24 link (5-wire) in DTE/DCE serial communication (3.0 V DTE)

<sup>10</sup> Voltage translator providing partial power down feature so that the 3 V supply can be ramped up before **V\_INT** 1.8 V supply

## UART with TXD and RXD lines only

Providing the **TXD** and **RXD** lines only is not recommended if the multiplexer functionality is used in the application: providing also at least the HW flow control (**RTS / CTS** lines) is recommended, and it is in particular necessary if the low power mode is enabled by +UPSV AT command.

If the functionality of the **CTS**, **RTS**, **DSR**, **DCD**, **RI** and **DTR** lines is not required in the application, or the lines are not available:

- Connect the module **RTS** input line to GND: since the module requires **RTS** active (low electrical level) if HW flow-control is enabled (AT&K3, which is the default setting).
- Connect the module **DTR** input to GND, since it may be useful to set **DTR** active if not specifically handled (see the AT commands manual [2], &D, S0, +CSGT, +CNMI AT commands)
- Leave the **DSR**, **DCD** and **RI** lines of the module floating, with a test-point on **DCD**

If RS-232 compatible signal levels are needed, the Maxim MAX13234E voltage level translator can be used. This chip translates voltage levels from 1.8 V (module side) to the RS-232 standard.

If a 1.8 V Application Processor (DTE) is used, the circuit should be implemented as in [Figure 52](#):

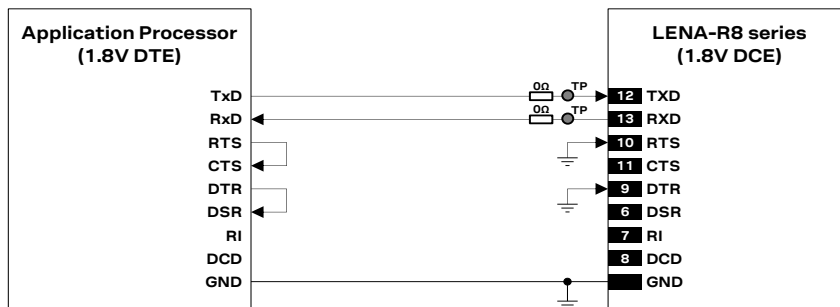

Figure 52: UART interface application circuit with partial V.24 link (3-wire) in the DTE/DCE serial communication (1.8 V DTE)

If a 3 V Application Processor (DTE) is used, it is recommended to connect the 1.8 V UART interface of the module (DCE) by means of appropriate unidirectional voltage translator using the module **V\_INT** output as 1.8 V supply for the voltage translator on the module side, as described in [Figure 53](#).

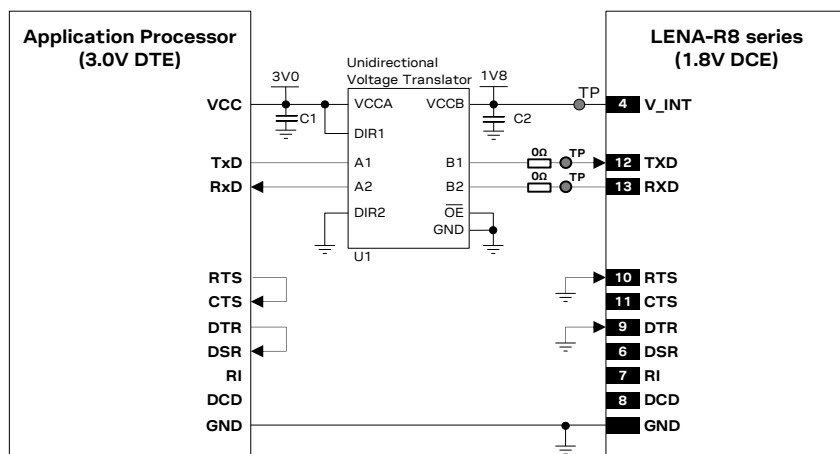

Figure 53: UART interface application circuit with partial V.24 link (3-wire) in DTE/DCE serial communication (3.0 V DTE)

Reference	Description	Part number - manufacturer
C1, C2	100 nF Capacitor Ceramic	Various Manufacturers
U1	Unidirectional Voltage Translator	SN74AVC2T245 <sup>11</sup> - Texas Instruments



Table 37: Parts for UART application circuit with partial V.24 link (3-wire) in DTE/DCE serial communication (3.0 V DTE)

<sup>11</sup> Voltage translator providing partial power down feature so that the 3 V supply can be ramped up before **V\_INT** 1.8 V supply

## Additional considerations

If a 3.0 V Application Processor (DTE) is used, the voltage scaling from any 3.0 V output of the DTE to the corresponding 1.8 V input of the module (DCE) can be implemented, as an alternative low-cost solution, by means of an appropriate voltage divider. Consider the value of the pull-up integrated at the input of the module (DCE) for the correct selection of the voltage divider resistance values and mind that any DTE signal connected to the module must be tri-stated or set low when the module is in power-down mode and during the module power-on sequence (at least until the activation of the **V\_INT** supply output of the module), to avoid latch-up of circuits and allow a proper boot of the module (see the remark below).

Moreover, the voltage scaling from any 1.8 V output of the cellular module (DCE) to the corresponding 3.0 V input of the Application Processor (DTE) can be implemented by means of a proper low-cost non-inverting buffer with open drain output. The non-inverting buffer should be supplied by the **V\_INT** supply output of the cellular module. Consider the value of the pull-up integrated at each input of the DTE (if any) and the baud rate required by the application for the appropriate selection of the resistance value for the external pull-up biased by the application processor supply rail.

-  Do not apply voltage to any UART interface pin before the switch-on of the UART supply source (**V\_INT**), to avoid latch-up of circuits and allow a proper boot of the module.
-  The ESD sensitivity rating of the UART pins is 1 kV (HBM according to JESD22-A114). Higher protection level could be required if the lines are externally accessible, and it can be achieved by mounting an ESD protection (e.g. EPCOS CA05P4S14THSG) close to the accessible points.
-  It is recommended to consider providing accessible test points on the UART **TXD** / **RXD** data lines and on the AUX UART **DTR** / **DCD** data lines, with a 0  $\Omega$  series jumper on each line, to detach the application processor for diagnostic purposes.

### 2.6.1.2 Guidelines for UART layout design

The UART serial interface requires the same considerations regarding electro-magnetic interference as any other digital interface. Keep the traces short and avoid coupling with RF line or sensitive analog inputs, since the signals can cause the radiation of some harmonics of the digital data frequency.

## 2.6.2 Cellular USB interface

### 2.6.2.1 Guidelines for USB circuit design

The **USB\_D+** and **USB\_D-** lines carry the USB serial data and signaling. USB pull-up or pull-down resistors and external series resistors on **USB\_D+** and **USB\_D-** lines as required by the USB 2.0 specification [11] are part of the module USB pins driver and do not need to be externally provided.

The USB interface of the module is enabled if a valid high logic level is detected by the **VUSB\_DET** input of the module (see the LENA-R8 series data sheet [1]). Neither the USB interface, nor the whole module is supplied by the **VUSB\_DET** input, which senses the voltage and absorbs few microamperes.

-  The **USB\_BOOT** input pin has to be set high, at the 1.8 V voltage level of the **V\_INT** supply output, to enable the FW update by means of the dedicated tool over the USB interface of the LENA-R8 series modules' cellular system.

Routing the USB pins to a connector, they will be externally accessible on the application device. According to the EMC/ESD requirements of the application, an additional ESD protection device with very low capacitance should be provided close to the accessible point on the line connected to this pin, as described in [Figure 54](#) and [Table 38](#).

ESD sensitivity rating of USB pins is 1 kV (HBM as per JESD22-A114F). Higher protection level could be required if the lines are externally accessible and it can be achieved by mounting a very low capacitance (i.e. less or equal to 1 pF) ESD protection (e.g. Littelfuse PESD0402-140 ESD protection device) on the lines connected to these pins, close to accessible points.

The USB pins of the modules can be directly connected to the USB host application processor without additional ESD protections if they are not externally accessible.

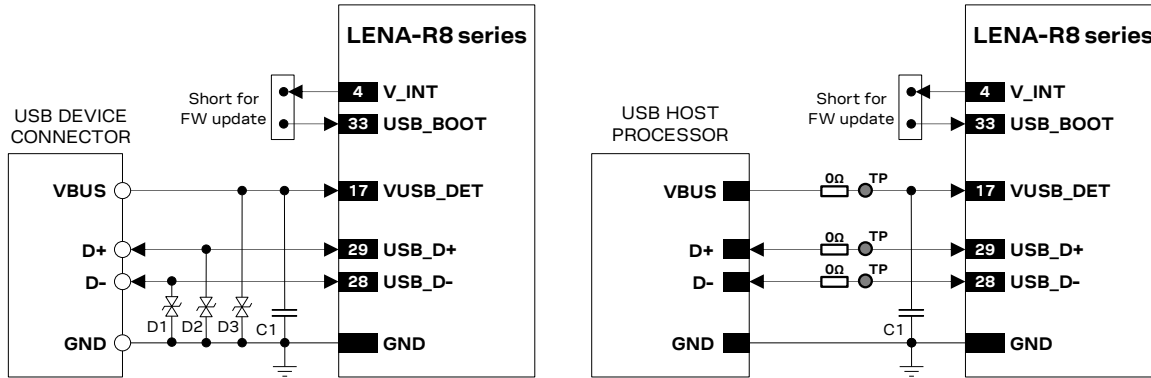

Figure 54: USB Interface application circuits

Reference	Description	Part number - manufacturer
C1	100 nF Capacitor Ceramic	Various Manufacturers
D1, D2, D3	Very Low Capacitance ESD Protection	PESD0402-140 - Littelfuse

Table 38: Component for USB application circuits

If the USB interface pins are not used, they can be left unconnected on the application board, but it is highly recommended to provide accessible Test-Points directly connected to the **VUSB\_DET**, **USB\_D+**, **USB\_D-** and **USB\_BOOT** pins, with a 0 Ω series jumper on each line to detach the external host processor for FW upgrade and/or for diagnostic purpose.

### 2.6.2.2 Guidelines for USB layout design

The **USB\_D+** / **USB\_D-** lines require accurate layout design to achieve reliable signaling at the high-speed data rate (up to 480 Mb/s) supported by the USB serial interface.

The characteristic impedance of the **USB\_D+** / **USB\_D-** lines is specified by the Universal Serial Bus Revision 2.0 specification [11]. The most important parameter is the differential characteristic impedance applicable for the odd-mode electromagnetic field, which should be as close as possible to 90 Ω differential. Signal integrity may be degraded if the PCB layout is not optimal, especially when the USB signaling lines are very long.

Use the following general routing guidelines to minimize signal quality problems:

- Route **USB\_D+** / **USB\_D-** lines as a differential pair.
- Route **USB\_D+** / **USB\_D-** lines as short as possible.
- Ensure the differential characteristic impedance ( $Z_0$ ) is as close as possible to 90 Ω.
- Ensure the common mode characteristic impedance ( $Z_{CM}$ ) is as close as possible to 30 Ω.
- Consider design rules for **USB\_D+** / **USB\_D-** as RF transmission lines, differential micro-strip or buried stripline: avoid any stubs, abrupt change of layout, and route on clear PCB area.
- Avoid coupling with any RF line or sensitive analog inputs, since the signals can cause the radiation of some harmonics of the digital data frequency.

Figure 55 and Figure 56 provide two examples of coplanar waveguide designs with differential characteristic impedance close to 90 Ω and common mode characteristic impedance close to 30 Ω. The first transmission line can be implemented for a 4-layer PCB stack-up herein described, the second transmission line can be implemented for a 2-layer PCB stack-up herein described.

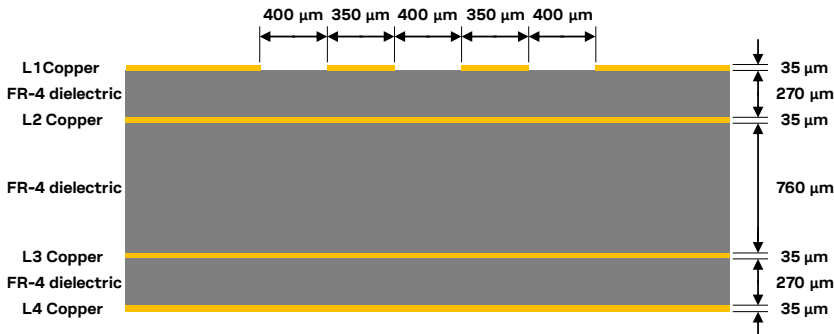

Figure 55: Example of USB line design, with  $Z_0$  close to  $90 \Omega$  and  $Z_{CM}$  close to  $30 \Omega$ , for the described 4-layer board layout

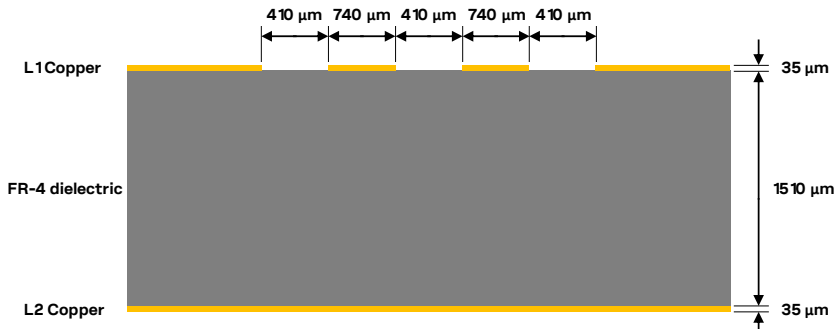

Figure 56: Example of USB line design, with  $Z_0$  close to  $90 \Omega$  and  $Z_{CM}$  close to  $30 \Omega$ , for the described 2-layer board layout

## 2.6.3 Cellular I2C interface

The support of the cellular I2C interface over **SDA** and **SCL** pins is not presented with the “00C” product version of the LENA-R8001M10 modules.

### 2.6.3.1 Guidelines for I2C circuit design

#### General considerations

The **SDA** and **SCL** pins of LENA-R8001 are open drain output as per I2C bus specifications [12], and they have internal active pull-ups to the **V\_INT** 1.8 V supply rail, so that external pull-up resistors are not strictly required, but they can be provided to increase the strength and improve signal integrity.

- Capacitance and series resistance must be limited on the bus to match the I2C specifications (maximum proper rise time for **SCL** / **SDA** lines is  $1.0 \mu\text{s}$ ): route connections as short as possible.
- Do not apply voltage to any UART interface pin before the switch-on of the UART supply source (**V\_INT**), to avoid latch-up of circuits and allow a proper boot of the module.
- The ESD sensitivity rating of the I2C pins is 1 kV (HBM as per JESD22-A114). Higher protection level could be required if the lines are externally accessible and it can be achieved by mounting an ESD protection (e.g. EPCOS CA05P4S14THSG varistor array) close to accessible points.
- If the pins are not used as I2C bus interface, they can be left unconnected.

#### Connection with u-blox 1.8 V GNSS receivers (LENA-R8001 modules only)

Figure 57 shows an application circuit for connecting the module to a u-blox 1.8 V GNSS receiver:

- The **SDA** and **SCL** pins of the cellular module are directly connected to the related pins of the u-blox 1.8 V GNSS receiver, with appropriate pull-up resistors connected to the 1.8 V GNSS supply enabled after the **V\_INT** supply of the I2C pins of the cellular module.

- The **GPIO2** pin is connected to the active-high enable pin of the voltage regulator that supplies the u-blox 1.8 V GNSS receiver, providing the “GNSS supply enable” function. A pull-down resistor is provided to avoid a switch-on of the GNSS when the module is switched off.
- The **GPIO3** pin is directly connected to the pin of the u-blox 1.8 V GNSS receiver providing “GNSS Tx data ready” function.

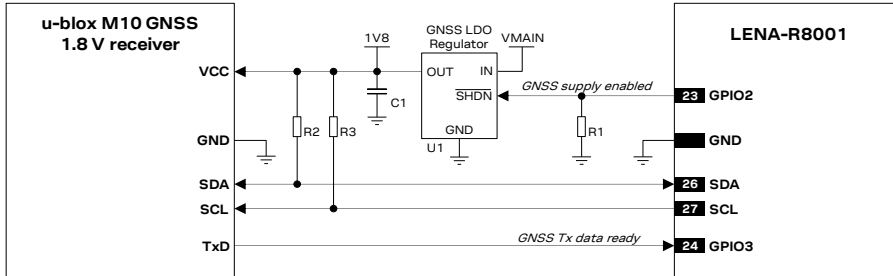
**Figure 57: Application circuit for connecting LENA-R8001 modules to u-blox 1.8 V GNSS receivers**

Reference	Description	Part number - manufacturer
R1	47 kΩ Resistor	Various Manufacturers
R2, R3	10 kΩ Resistor	Various Manufacturers
U1, C1	Voltage Regulator for GNSS receiver and related output bypass capacitor	See GNSS receiver Hardware Integration Manual

**Table 39: Components for connecting LENA-R8001 modules to u-blox 1.8 V GNSS receivers**

Figure 58 illustrates an alternative solution as a supply circuit for u-blox 1.8 V GNSS receivers, using the **V\_INT** 1.8 V supply output of the cellular module, generated by an internal linear LDO regulator, to supply an external u-blox 1.8 V GNSS receiver instead of using an external voltage regulator as in the previous Figure 57. The **V\_INT** 1.8 V supply output of the cellular module can sustain the maximum current consumption of the u-blox 1.8 V GNSS receivers.

The internal linear LDO regulator that generates the **V\_INT** supply is set to 1.8 V (typical) when the cellular module is switched on, and it is disabled when the cellular module is switched off: in such case, implementing the circuit illustrated in Figure 58, the external u-blox 1.8 V GNSS receiver will result not supplied when the cellular module is switched off.

In the application circuit example illustrated in Figure 58, the supply of the u-blox 1.8 V GNSS receiver is switched on/off using an external p-channel MOSFET controlled by the **GPIO2** output of the cellular module by means of a proper inverting transistor, implementing the “GNSS supply enable” function.

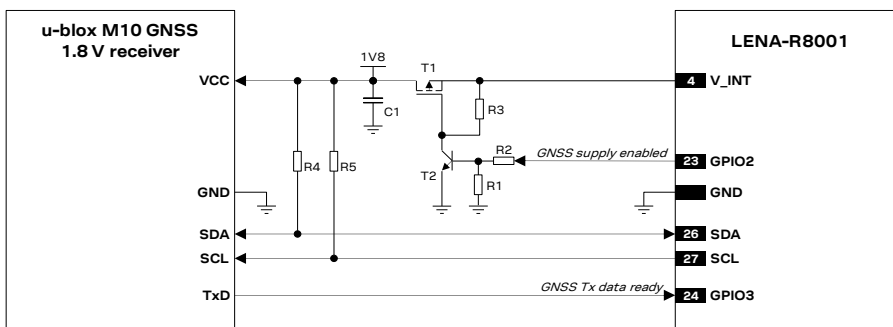
**Figure 58: Application circuit for connecting LENA-R8001 modules to u-blox 1.8 V GNSS receivers using V\_INT as supply**

Reference	Description	Part number - manufacturer
R1	47 kΩ Resistor	Various Manufacturers
R2, R4, R5	10 kΩ Resistor	Various Manufacturers
R3	100 kΩ Resistor	Various Manufacturers

Reference	Description	Part number - manufacturer
T1	P-Channel MOSFET Low On-Resistance	IRLML6401 - International Rectifier or NTZS3151P - ON Semi
T2	NPN BJT Transistor	BC847 - Infineon
C1	100 nF Capacitor Ceramic	Various Manufacturers

**Table 40: Components for connecting LENA-R8 series modules to u-blox 1.8 V GNSS receivers using V\_INT as supply**

For additional guidelines regarding the design of applications with u-blox 1.8 V GNSS receivers, see the Integration Manual of the selected u-blox GNSS receiver. It is recommended to consider and implement all the possible measures for proper RF coexistence of the Cellular and the GNSS systems.

### Connection with u-blox 3.0 V GNSS receivers (LENA-R8001 modules only)

Figure 59 shows an application circuit for connecting the module to a u-blox 3.0 V GNSS receiver:

- The 1.8 V pins **SDA** and **SCL** of the cellular module are connected to the related pins of the u-blox 3.0 V GNSS receiver using a proper I2C-bus Bidirectional Voltage Translator (as the TI TCA9406), with pull-up resistors where appropriate.
- The **GPIO2** is connected to the active-high enable pin of the voltage regulator that supplies the u-blox 3.0 V GNSS receiver providing the “GNSS supply enable” function. A pull-down resistor is provided to avoid a switch-on of the positioning receiver when the cellular module is switched off.
- The 1.8 V pin **GPIO3** of the cellular module is connected to the related pin of the u-blox 3.0 V GNSS receiver implementing the “GNSS Tx data ready” function using a proper Unidirectional Voltage Translator (as the TI SN74AVC2T245).

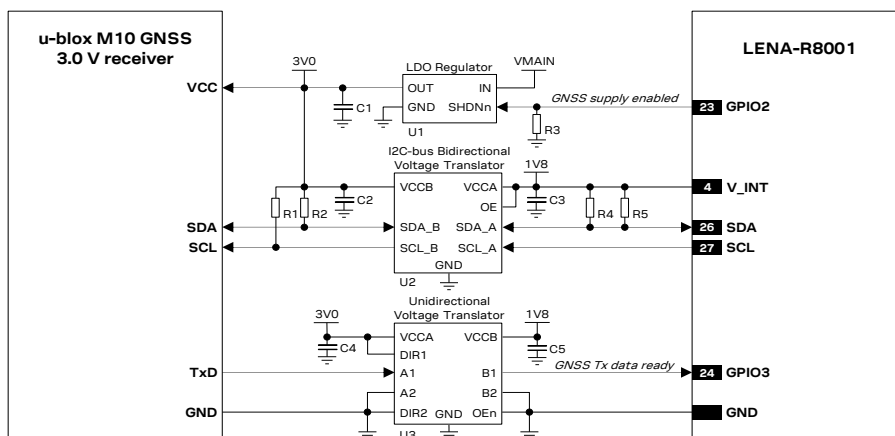
**Figure 59: Application circuit for connecting LENA-R8001 modules to u-blox 3.0 V GNSS receivers**

Reference	Description	Part number - manufacturer
R1, R2, R4, R5	10 kΩ Resistor	Various Manufacturers
R3	47 kΩ Resistor	Various Manufacturers
C2, C3, C4, C5	100 nF Capacitor Ceramic	Various Manufacturers
U1, C1	Voltage Regulator for GNSS receiver and related output bypass capacitor	See GNSS receiver Hardware Integration Manual
U2	I2C-bus Bidirectional Voltage Translator	TCA9406DCUR <sup>12</sup> - Texas Instruments
U3	Unidirectional Voltage Translator	SN74AVC2T245 <sup>12</sup> - Texas Instruments

**Table 41: Components for connecting LENA-R8001 modules to u-blox 3.0 V GNSS receivers**

For additional guidelines regarding the design of applications with u-blox 3.0 V GNSS receivers, the Integration Manual of the selected u-blox GNSS receiver. It is recommended to consider and implement all the possible measures for proper RF coexistence of the Cellular and the GNSS systems.

<sup>12</sup> Voltage Translator providing the partial power down feature for back-drive protection.

### 2.6.3.2 Guidelines for I2C layout design

The I2C serial interface requires the same considerations regarding electro-magnetic interference as any other digital interface. Keep the traces short and avoid coupling with RF line or sensitive analog inputs, since the signals can cause the radiation of some harmonics of the digital data frequency.

## 2.7 Cellular audio interface

### 2.7.1 Cellular digital audio interface

The support of the cellular I2S digital audio interface function over **I2S\_TXD**, **I2S\_RXD**, **I2S\_CLK** and **I2S\_WA** pins is not presented with the “00C” product version of LENA-R8 series modules.

## 2.8 Cellular General Purpose Input/Output (GPIO)

### 2.8.1.1 Guidelines for GPIO circuit design

A typical usage of LENA-R8 series modules' GPIOs can be the following:

- Network indication provided over **GPIO1** pin (see [Figure 60](#) / [Table 42](#) below)
- GNSS supply enable function provided by the **GPIO2** pin (see [section 2.6.3](#))
- GNSS Tx data ready function provided by the **GPIO3** pin (see [section 2.6.3](#))

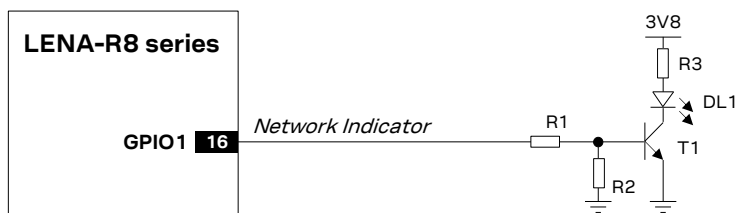

**Figure 60: Application circuit for network indication provided over GPIO1**

Reference	Description	Part number - manufacturer
R1	10 kΩ Resistor 0402 5% 0.1 W	Various manufacturers
R2	47 kΩ Resistor 0402 5% 0.1 W	Various manufacturers
R3	820 Ω Resistor 0402 5% 0.1 W	Various manufacturers
DL1	LED Red SMT 0603	LTST-C190KRKT - Lite-on Technology Corporation
T1	NPN BJT Transistor	BC847 - Infineon

**Table 42: Components for network indication application circuit**

- Use transistors with at least an integrated resistor in the base pin or otherwise put a 10 kΩ resistor on the board in series to the GPIO of LENA-R8 series modules.
- Do not apply voltage to any GPIO of the module before the switch-on of the GPIOs supply (**V\_INT**), to avoid latch-up of circuits and allow a proper module boot.
- ESD sensitivity rating of GPIO pins is 1 kV (HBM according to JESD22-A114). Higher protection level could be required if the lines are externally accessible and it can be achieved by mounting an ESD protection (e.g. EPCOS CA05P4S14THSG varistor array) close to accessible points.
- If the GPIO pins are not used, they can be left unconnected on the application board.

### 2.8.1.2 Guidelines for GPIO layout design

The GPIO pins are generally not critical for layout.

## 2.9 Reserved pins (RSVD)

LENA-R8 series modules have pins reserved for possible future use, named **RSVD**: they can all be left unconnected on the application board.

## 2.10 GNSS power management

LENA-R8001 modules do not include a GNSS receiver: GNSS power management is not available.

### 2.10.1 GNSS supply input (VCC\_GNSS)

Connecting an external DC power supply at the **VCC\_GNSS** input is necessary for normal operations of the LENA-R8001M10 GNSS system, considering **VCC\_GNSS** pin provides power to the GNSS RF domains and internal LNA, the GNSS system core, the GNSS digital peripheral I/O, the dedicated TCXO through an integrated LDO regulator, as is illustrated in [Figure 2](#).

Voltage at **VCC\_GNSS** must be clean, stable, and tight at 1.8 V to properly supply the GNSS system.

During operation, the current drawn by the GNSS system may vary. For this reason, it is important that the supply circuitry is able to support the peak power for a short time.

External circuits using linear LDO regulators or DC/DC switching regulators can be implemented to provide the clean, stable, and tight 1.8 V supply at the **VCC\_GNSS** input.

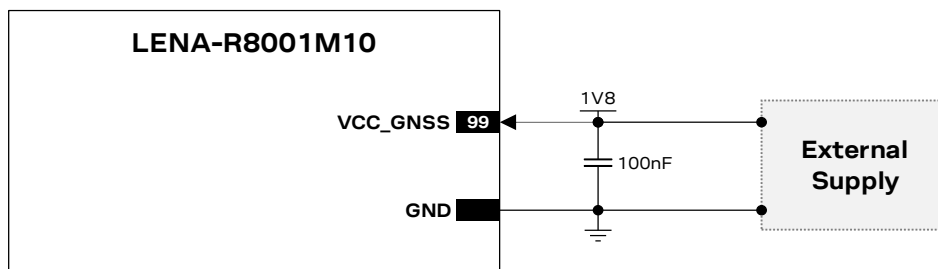

**Figure 61: Application circuit for LENA-R8001M10 modules GNSS system supply using external 1.8 V supply system**

- Do not add series resistance greater than  $0.2\ \Omega$  along the **VCC\_GNSS** supply line, to avoid voltage ripple due to the dynamic current conditions.
- The voltage supply ramp at the **VCC\_GNSS** input must not exceed the minimum specified voltage ramp. Otherwise, the receiver might get damaged.
- For more information about **VCC\_GNSS** voltage range, voltage ramp and current consumption characteristics to appropriately select and design an external supply circuit, see the LENA-R8 series data sheet [\[1\]](#).
- For more information and examples about GNSS main supply external circuit guidelines, see the u-blox M10 standard precision GNSS chip data sheet [\[3\]](#) and integration manual [\[4\]](#).

[Figure 62](#) illustrates an alternative solution using the **V\_INT** 1.8 V supply output of the cellular system, generated by an internal linear LDO regulator, to supply the **VCC\_GNSS** input of LENA-R8001M10 GNSS system instead of using an external voltage regulator. The **V\_INT** 1.8 V supply output of the cellular module can sustain the maximum current consumption of LENA-R8001M10 GNSS system.

The internal linear LDO regulator generating the **V\_INT** supply is enabled when the cellular system is switched on, and it is disabled when the cellular system is switched off: using the circuit in [Figure 62](#), the GNSS system will result not supplied when the cellular system is switched off.

In the application circuit example illustrated in Figure 62, the supply of the GNSS system is switched on/off using an external p-channel MOSFET controlled by the **GPIO2** output of the cellular system by means of a proper inverting transistor, implementing the “GNSS supply enable” function.

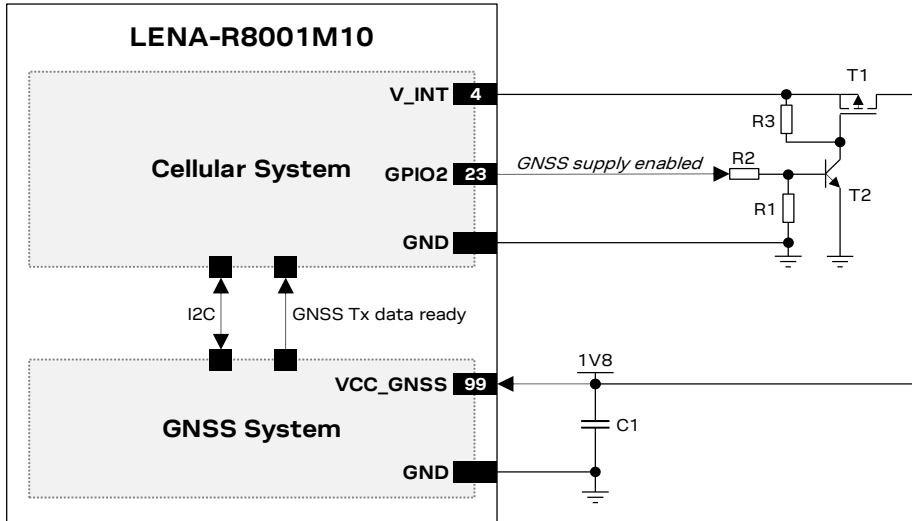

Figure 62: Application circuit for LENA-R8001M10 modules GNSS system supply using LENA-R8001M10 cellular system

Reference	Description	Part number - manufacturer
R1	47 kΩ Resistor	Various Manufacturers
R2	10 kΩ Resistor	Various Manufacturers
R3	100 kΩ Resistor	Various Manufacturers
T1	P-Channel MOSFET Low On-Resistance	IRLML6401 - International Rectifier or NTZS3151P - ON Semi
T2	NPN BJT Transistor	BC847 - Infineon
C1	100 nF Capacitor Ceramic	Various Manufacturers

Table 43: Components for LENA-R8001M10 modules GNSS system supply using LENA-R8001M10 cellular system

- Use a load switch / MOS transistor with very low on-resistance, keeping the series resistance lower than 0.2 Ω along the **VCC\_GNSS** supply line, to avoid voltage ripple due to the dynamic current conditions.

## 2.10.2 GNSS backup supply input (VBCKP\_GNSS)

The **VBCKP\_GNSS** pin is the backup supply input for the GNSS system of the LENA-R8001M10 modules, designed to keep the GNSS backup RAM memory and the GNSS RTC alive in case of voltage interruption at the main **VCC\_GNSS** input pin.

Connecting an external DC power supply at the **VBCKP\_GNSS** input is optional. If present, it enables the hardware backup mode when the main **VCC\_GNSS** supply is not present.

- Do not add series resistance greater than 0.2 Ω on the **VBCKP\_GNSS** supply line, to avoid voltage ripple due to the dynamic current conditions.
- The voltage supply ramp at the **VBCKP\_GNSS** input must not exceed the minimum specified voltage ramp. Otherwise, the receiver might get damaged.
- For more information about **VBCKP\_GNSS** voltage range, voltage ramp and current consumption characteristics to appropriately select and design an external supply circuit, see the LENA-R8 series data sheet [1].
- For more information and examples about GNSS back-up supply external circuit guidelines, see the u-blox M10 standard precision GNSS chip data sheet [3] and integration manual [4].

## 2.11 GNSS serial communication interface

LENA-R8001 modules do not include a GNSS receiver: GNSS UART interface is not available.

### 2.11.1 GNSS UART interface

The GNSS UART of LENA-R8001M10 modules, consisting of the **RXD\_GNSS** data input line and the **TXD\_GNSS** data output line of the internal u-blox M10 GNSS chipset as is illustrated in [Figure 2](#), can be used as serial interface for direct communication between the internal u-blox M10 GNSS chipset and an external host.

In case 1.8 V external host application processor use, the GNSS UART can be directly connected as illustrated in [Figure 63](#).

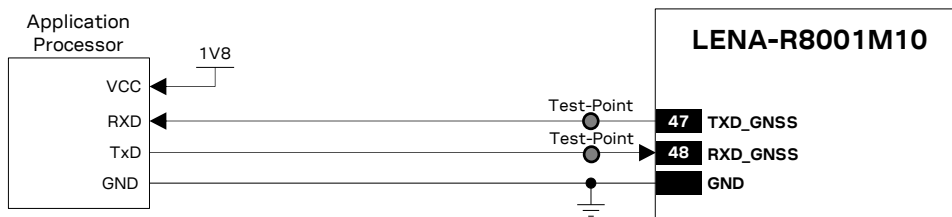

**Figure 63: Application circuit for LENA-R8001M10 GNSS UART with 1.8 V external host application processor**

In case 3 V external host application processor use, the GNSS UART has to be connected using proper voltage translator as illustrated in [Figure 64](#).

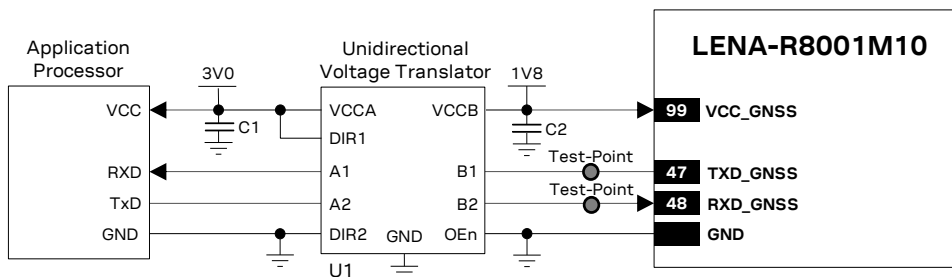

**Figure 64: Application circuit for LENA-R8001M10 GNSS UART with 3 V external host application processor**

Reference	Description	Part number - manufacturer
C1, C2	100 nF Capacitor Ceramic	Various Manufacturers
U1	Unidirectional Voltage Translator	SN74AVC2T245 <sup>12</sup> - Texas Instruments

**Table 44: Components for LENA-R8001M10 GNSS UART with 3 V external host application processor**

It is recommended to provide access to the **RXD\_GNSS** and **TXD\_GNSS** pins of LENA-R8001M10 modules for diagnostic purpose, by means of test points directly connected to the pins.

As long as **VCC\_GNSS** is not supplied, the GNSS UART pins cannot be driven by an external host processor. If driving the GNSS UART pins cannot be avoided, buffers are required for isolating the GNSS UART pins.

For more information and examples about GNSS UART external circuit guidelines, see the u-blox M10 standard precision GNSS chip data sheet [\[3\]](#) and integration manual [\[4\]](#).

## 2.12 GNSS Peripheral Input/Output

LENA-R8001 modules do not include a GNSS receiver: GNSS PIOs are not available.

The GNSS peripheral input/output pins of LENA-R8001M10 modules, consisting of the **TIMEPULSE** output pin and the **EXTINT** external interrupt input pin as is illustrated in [Figure 2](#), can be connected

to an external host processor if their functions are required by the application, otherwise they can be left unconnected in the application board.

In case 1.8 V external processor, the GNSS PIOs can be directly connected as illustrated in [Figure 65](#).

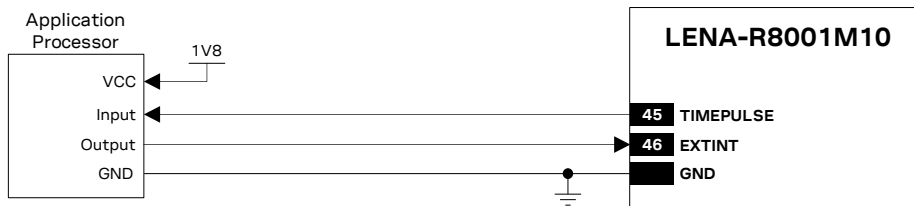

**Figure 65: Application circuit for LENA-R8001M10 GNSS PIOs with 1.8 V external host application processor**

In case 3 V external processor, the GNSS PIOs have to be connected using proper voltage translator as illustrated in [Figure 66](#).

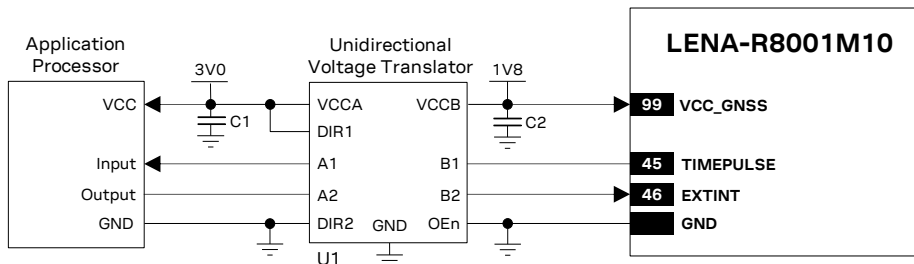

**Figure 66: Application circuit for LENA-R8001M10 GNSS PIOs with 3 V external host application processor**

Reference	Description	Part number - manufacturer
C1, C2	100 nF Capacitor Ceramic	Various Manufacturers
U1	Unidirectional Voltage Translator	SN74AVC2T245 <sup>12</sup> - Texas Instruments

**Table 45: Components for LENA-R8001M10 GNSS PIOs with 3 V external host application processor**

As long as **VCC\_GNSS** is not supplied, the GNSS UART pins cannot be driven by an external host processor. If driving the GNSS UART pins cannot be avoided, buffers are required for isolating the GNSS UART pins.

For more information and examples about GNSS PIOs external circuit guidelines, see the u-blox M10 standard precision GNSS chip data sheet [\[3\]](#) and integration manual [\[4\]](#).

## 2.13 Module placement

Optimize placement for a minimum length of RF line and a closer path from the DC source for **VCC**.

Make sure that the module, RF and analog parts / circuits are clearly separated from any possible source of radiated energy, including digital circuits that can radiate some digital frequency harmonics, which can produce Electro-Magnetic Interference affecting module, RF and analog parts / circuits' performance or implement proper countermeasures to avoid any possible EMC / EMI issue.

Routing of noisy signals below the module, on the top layer of the host PCB, is not recommended.

Make sure that the module, RF and analog parts / circuits, high speed digital circuits are clearly separated from any sensitive part / circuit which may be affected by Electro-Magnetic Interference or employ countermeasures to avoid any possible Electro-Magnetic Compatibility issues.

Provide enough clearance between the module and any external part.

The heat dissipation during continuous transmission at maximum power can significantly raise the temperature of the application base-board below the LENA-R8 series modules: avoid placing temperature sensitive devices close to the module.

## 2.14 Module footprint and paste mask

Figure 67 and Table 46 describe the suggested footprint (i.e. copper mask) and paste mask layout for LENA modules: the proposed land pattern layout reflects the modules' pins layout, while the proposed stencil apertures layout is slightly different (see the F'', H'', I'', J'', O'' parameters compared to the F', H', I', J', O' ones).

The Non Solder resist Mask Defined (NSMD) pad type is recommended over the Solder resist Mask Defined (SMD) pad type, implementing the solder mask opening 50  $\mu\text{m}$  larger per side than the corresponding copper pad.

The recommended solder paste thickness is 150  $\mu\text{m}$ , according to application production process requirements.

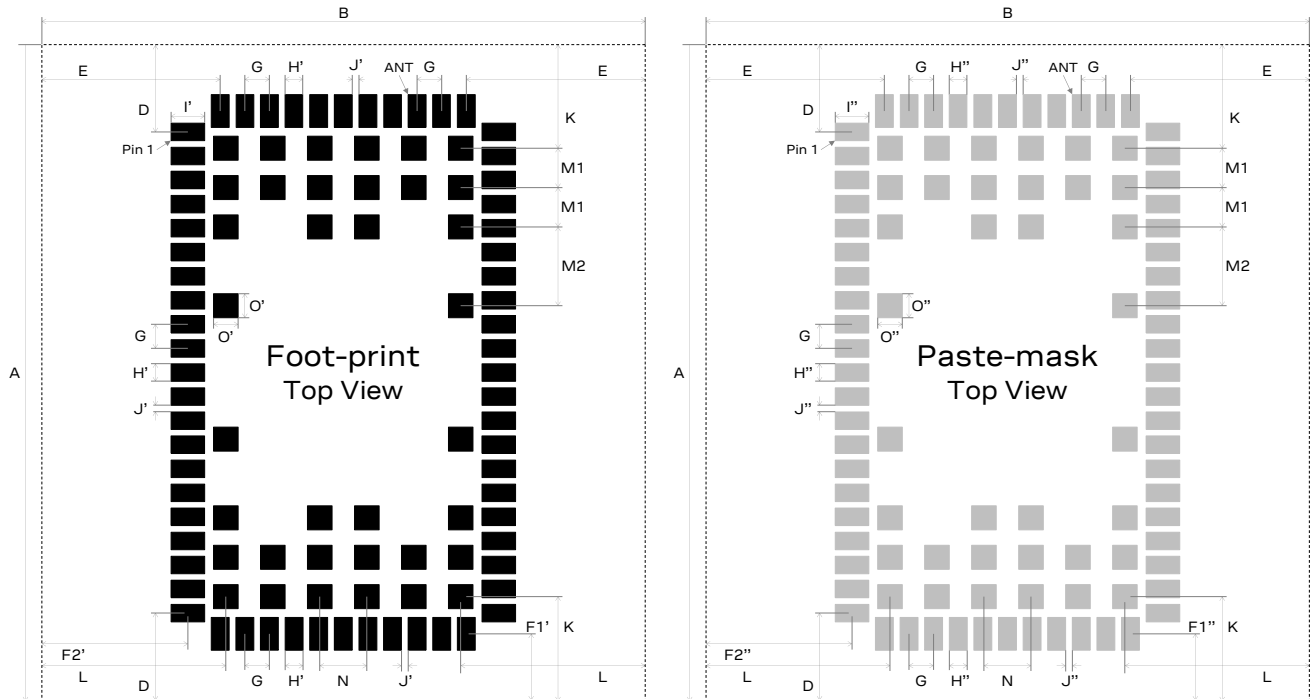



Figure 67: LENA-R8 series modules suggested footprint and paste mask (application board top view)

Parameter	Value	Parameter	Value	Parameter	Value
A	30.0 mm	G	1.10 mm	K	4.75 mm
B	27.0 mm	H'	0.80 mm	L	8.25 mm
D	4.00 mm	H''	0.75 mm	M1	1.80 mm
E	8.00 mm	I'	1.50 mm	M2	3.60 mm
F1'	3.05 mm	I''	1.55 mm	N	2.10 mm
F1''	3.00 mm	J'	0.30 mm	O'	1.10 mm
F2'	6.65 mm	J''	0.35 mm	O''	1.05 mm
F2''	6.50 mm				

Table 46: LENA-R8 series modules suggested footprint and paste mask dimensions

These are recommendations only and not specifications. The exact copper, solder and paste mask geometries, distances, stencil thicknesses and solder paste volumes must be adapted to the specific production processes (e.g. soldering etc.) of the customer.

## 2.15 Thermal guidelines

 Modules' operating temperature range is specified in the LENA-R8 series data sheet [1].

The most critical condition concerning module thermal performance is the uplink transmission at maximum power (data upload in connected mode), when the baseband processor runs at full speed, radio circuits are all active and the RF power amplifier is driven to higher output RF power. This scenario is not often encountered in real networks (for example, see the Terminal Tx Power distribution for WCDMA, taken from operation on a live network, described in the GSMA TS.09 Battery Life Measurement and Current Consumption Technique [17]); however the application should be correctly designed to cope with it.

During transmission at maximum RF power, the LENA-R8 series modules generate thermal power that may exceed 2 W: this is an indicative value since the exact generated power strictly depends on operating condition such as the actual antenna return loss, the number of allocated TX resource blocks, the transmitting frequency band, etc. The generated thermal power must be adequately dissipated through the thermal and mechanical design of the application.

The spreading of the Module-to-Ambient thermal resistance ( $R_{th,M-A}$ ) depends on the module operating condition. The overall temperature distribution is influenced by the configuration of the active components during the specific mode of operation and their different thermal resistance toward the case interface.

 The Module-to-Ambient thermal resistance value and the relative increase of module temperature will differ according to the specific mechanical deployments of the module, e.g. application PCB with different dimensions and characteristics, mechanical shells enclosure, or forced air flow.

The increase of the thermal dissipation, i.e. the reduction of the Module-to-Ambient thermal resistance, will decrease the temperature of the modules' internal circuitry for a given operating ambient temperature. This improves the device long-term reliability in particular for applications operating at high ambient temperature.

Recommended hardware techniques to be used to improve heat dissipation in the application:

- Connect each **GND** pin with solid ground layer of the application board and connect each ground area of the multilayer application board with a complete thermal via stacked down to the main ground layer.
- Provide a ground plane as wide as possible on the application board.
- Optimize antenna return loss, to optimize overall electrical performance of the module including a decrease of module thermal power.
- Optimize the thermal design of any high-power components included in the application, such as linear regulators and amplifiers, to optimize overall temperature distribution in the device.
- Select the material, the thickness and the surface of the box (i.e. the mechanical enclosure) of the application device that integrates the module so that it provides good thermal dissipation.

Further HW techniques that may be considered to improve the heat dissipation in the application:

- Force ventilation air-flow within the mechanical enclosure.
- Provide a heat sink component attached to the module top side, with electrically insulated / high thermal conductivity adhesive, or on the backside of the application board, below the cellular module, as a large part of the heat is transported through the GND pads of the LENA-R8 series LGA modules and dissipated over the backside of the application board.

For example, the Module-to-Ambient thermal resistance ( $R_{th,M-A}$ ) is strongly reduced with forced air ventilation and a heat-sink installed on the back of the application board, decreasing the module temperature variation.

## 2.16 Schematic for LENA-R8 series module integration

Figure 68 is an illustrative example of a schematic diagram where a LENA-R8001 cellular module is integrated into an application board, using almost all the interfaces and functions of the module.

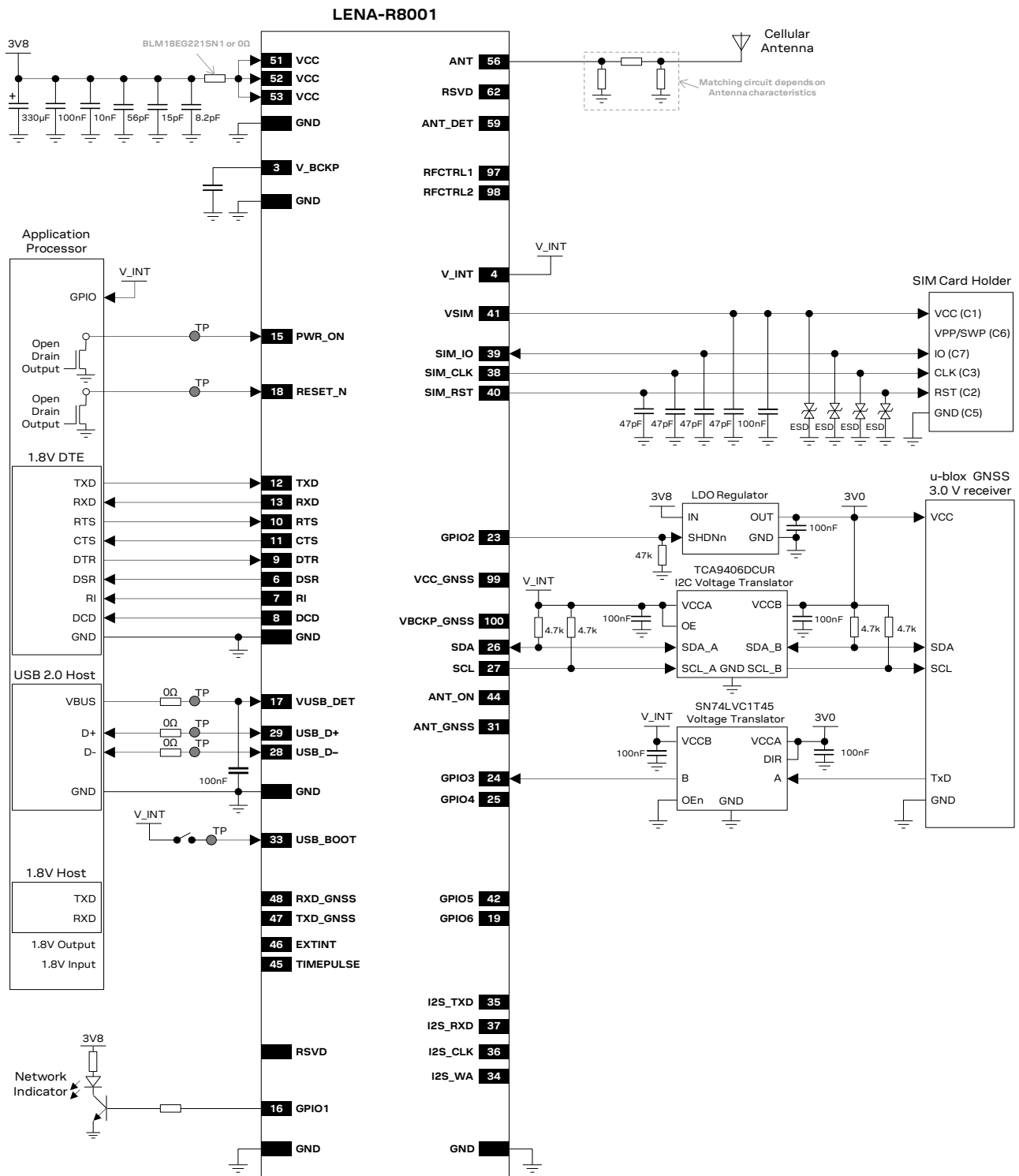

Figure 68: Illustrative example of schematic diagram to integrate a LENA-R8001 module using almost all interfaces

Figure 69 is an illustrative example of a schematic diagram where a LENA-R8001M10 cellular / GNSS module is integrated into an application board, using almost all the available interfaces and functions of the module.

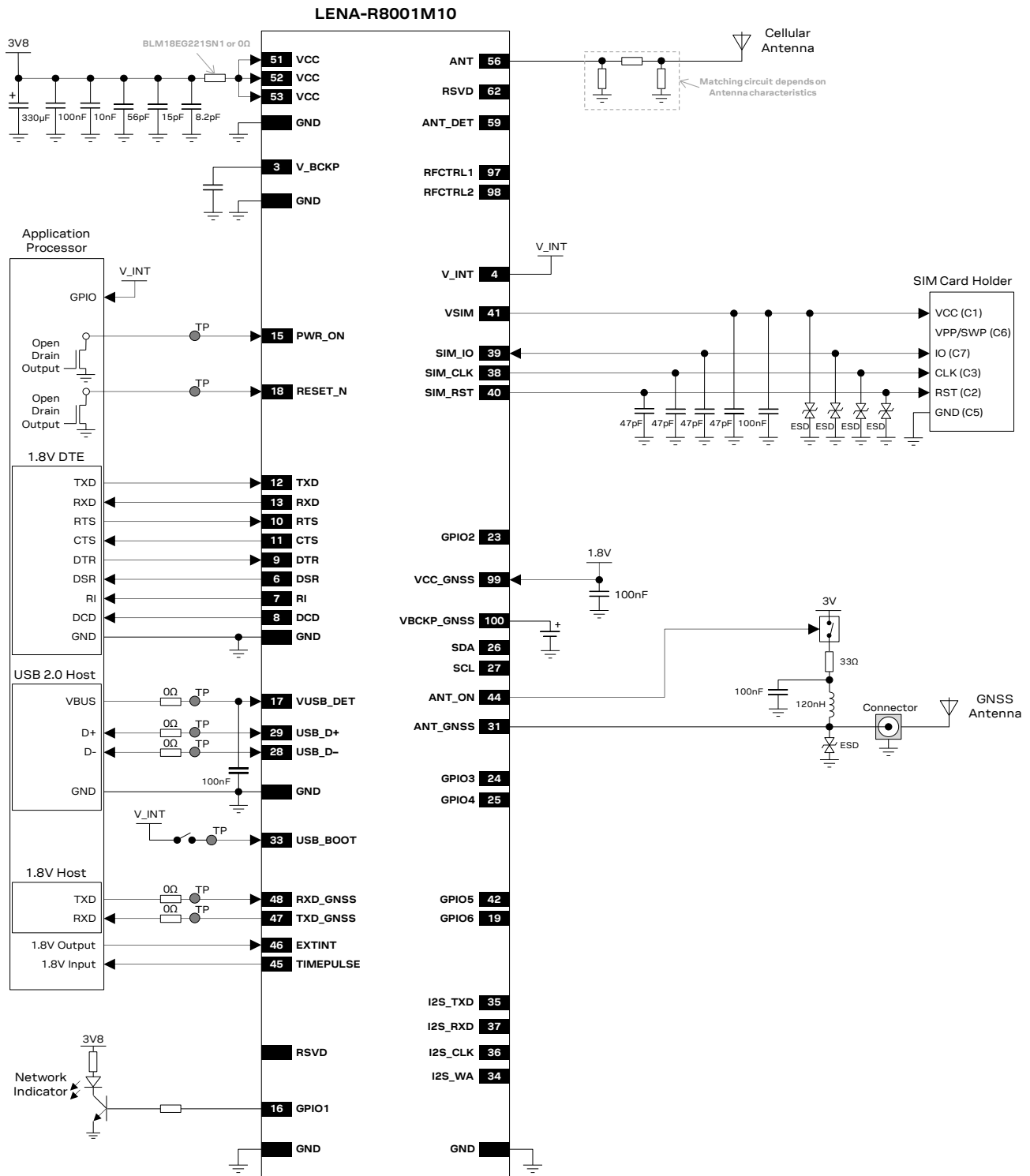

Figure 69: Illustrative example of schematic diagram to integrate a LENA-R8001M10 module using almost all interfaces

## 2.17 Design-in checklist

This section provides a design-in checklist.

### 2.17.1 Schematic checklist

The following are the most important points for a simple schematic check:

- ✓ DC supply must provide a nominal voltage at the **VCC** pins within the operating range limits.
- ✓ DC supply at the **VCC** pins must be capable of supporting both the highest peak and the highest averaged consumption values in connected mode, as specified in LENA-R8 series data sheet [1].
- ✓ **VCC** voltage supply should be clean, with very low ripple/noise: provide the suggested bypass capacitors, in particular if the application device integrates an internal antenna.
- ✓ Minimize series resistance along the **VCC** path.
- ✓ Do not apply loads which might exceed the limit for maximum available current from **V\_INT** supply.
- ✓ Check that the voltage level of any connected pin does not exceed the relative operating range.
- ✓ Provide accessible test points directly connected to the following pins of the modules:
  - **V\_INT**, **PWR\_ON** and **RESET\_N** for diagnostic purpose,
  - **VUSB\_DET**, **USB\_D+**, **USB\_D-** and **USB\_BOOT** for FW update and diagnostic purpose.
- ✓ Consider providing accessible test points on the UART **TXD** / **RXD** data lines and on the AUX UART **DTR** / **DCD** data lines, with a 0  $\Omega$  series jumper on each line, to detach the application processor for diagnostic purposes.
- ✓ Capacitance and series resistance must be limited on each line of the SIM interface to match the rise / fall time defined by SIM interface specifications.
- ✓ Insert the suggested pF capacitors on each SIM signal and low capacitance ESD protections if the SIM connector is accessible.
- ✓ Check UART interfaces signals direction, as the modules' signal names follow the ITU-T V.24 Recommendation [7]: **TXD** is the module UART data input, **RXD** is the module UART data output.
- ✓ Capacitance and series resistance must be limited on each high-speed line of the USB interface.
- ✓ Use transistors with at least an integrated resistor in the base pin or otherwise put a 10 k $\Omega$  resistor on the board in series to the GPIO when those are used to drive LEDs.
- ✓ Provide proper precautions for ESD immunity as required on the application board.
- ✓ Do not apply voltage to any generic digital interface pin of LENA-R8 series modules before the switch-on of the generic digital interface supply source (**V\_INT**).
- ✓ GNSS DC supply must provide a tight nominal voltage at the **VCC\_GNSS** pin within the operating range limits.
- ✓ GNSS DC supply at the **VCC\_GNSS** pin must be capable of supporting both the highest peak and the highest averaged consumption values in connected mode, as specified in LENA-R8 series data sheet [1].
- ✓ **VCC\_GNSS** voltage supply should be clean, with very low ripple/noise, tight at 1.8V.
- ✓ Minimize series resistance along the **VCC\_GNSS** path.
- ✓ Implement a back-up power supply at **VBCKP\_GNSS** in case it is required to enable the GNSS hardware backup mode when the main GNSS supply **VCC\_GNSS** is not present.
- ✓ Check GNSS UART interfaces signals direction, as the modules' signal names follow this rule: **GNSS\_RXD** is the module GNSS UART data input, **GNSS\_TXD** is the module GNSS UART data output.
- ✓ Do not apply voltage to any GNSS digital interface pin of the LENA-R8001M10 modules before applying the GNSS digital interface supply source (**VCC\_GNSS**).

## 2.17.2 Layout checklist

The following are the most important points for a simple layout check:

- ☑ Check 50  $\Omega$  nominal characteristic impedance of the RF transmission line connected to the **ANT** and the **ANT\_GNSS** ports (antenna RF interfaces).
- ☑ Ensure no coupling occurs between the RF interface and noisy or sensitive signals (primarily the **VCC** line, analog audio input/output signals, SIM signals, high-speed digital lines such as USB, and other data lines).
- ☑ Optimize placement for minimum length of RF line.
- ☑ Check the footprint and paste mask designed for the module as illustrated in section 2.14.
- ☑ Route **VCC** supply line away from RF lines / parts and other sensitive analog lines / parts.
- ☑ The **VCC** bypass capacitors in the picoFarad range should be placed as close as possible to the **VCC** pins, in particular if the application device integrates an internal antenna.
- ☑ Ensure an optimal grounding connecting each **GND** pin with application board solid ground layer.
- ☑ Use as many vias as possible to connect the ground planes on a multilayer application board, providing a dense line of vias at the edges of each ground area, in particular along the RF and high speed lines.
- ☑ Keep routing short and minimize parasitic capacitance on the SIM lines to preserve signal integrity.
- ☑ **USB\_D+** / **USB\_D-** traces should meet the characteristic impedance requirement (90  $\Omega$  differential and 30  $\Omega$  common mode) and should not be routed close to any RF line / part.
- ☑ Ensure appropriate RF precautions for the RF coexistence of GNSS and Cellular technologies.

## 2.17.3 Antenna checklist

- ☑ Antenna termination should provide a 50  $\Omega$  characteristic impedance with VSWR at least less than 3:1 (recommended 2:1) on operating bands in the deployment geographical area.
- ☑ Follow the recommendations of the antenna producer for correct antenna installation and deployment (PCB layout and matching circuitry).
- ☑ Ensure compliance with any regulatory agency RF radiation requirement, as for example reported in sections 4.2.2 and/or 4.3.1 for FCC US and/or ISED Canada.
- ☑ Ensure high isolation between the cellular antennas and any other antenna or transmitter.
- ☑ Ensure high isolation between the cellular and the GNSS antennas.

## 3 Handling and soldering

 No natural rubbers, no hygroscopic materials or materials containing asbestos are employed.

### 3.1 Packaging, shipping, storage, and moisture preconditioning

For information pertaining to LENA-R8 series reels / tapes, Moisture Sensitivity levels (MSD), shipment and storage information, as well as drying for preconditioning, see the LENA-R8 series data sheet [1] and the u-blox package information user guide [18].

### 3.2 Handling

The LENA-R8 series modules are Electro-Static Discharge (ESD) sensitive devices.

 Ensure ESD precautions are implemented during handling of the module.



Electrostatic discharge (ESD) is the sudden and momentary electric current that flows between two objects at different electrical potentials caused by direct contact or induced by an electrostatic field. The term is usually used in the electronics and other industries to describe momentary unwanted currents that may cause damage to electronic equipment.

The ESD sensitivity for each pin of the LENA-R8 series modules (as Human Body Model according to JESD22-A114F) is specified in the LENA-R8 series data sheet [1].

ESD prevention is based on establishing an Electrostatic Protective Area (EPA). The EPA can be a small working station or a large manufacturing area. The main principle of an EPA is that there are no highly charging materials near ESD sensitive electronics, all conductive materials are grounded, workers are grounded, and charge build-up on ESD sensitive electronics is prevented. International standards are used to define typical EPA and can be obtained for example from International Electrotechnical Commission (IEC) or American National Standards Institute (ANSI).

In addition to standard ESD safety practices, the following measures should be taken into account whenever handling the LENA-R8 series modules:

- Unless there is a galvanic coupling between the local GND (i.e. the work table) and the PCB GND, then the first point of contact when handling the PCB must always be between the local GND and PCB GND.
- Before mounting an antenna patch, connect the ground of the device.
- When handling the module, do not come into contact with any charged capacitors and be careful when contacting materials that can develop charges, e.g. patch antenna, coax cable, soldering iron, etc..
- To prevent electrostatic discharge through the RF pin, do not touch any exposed antenna area. If there is any risk that such exposed antenna area is touched in a non-ESD protected work area, implement proper ESD protection measures in the design.
- When soldering the module and patch antennas to the RF pin, make sure to use an ESD safe soldering iron.

## 3.3 Soldering

### 3.3.1 Soldering paste

Use of "No Clean" soldering paste is strongly recommended, as it does not require cleaning after the soldering process has taken place. The paste listed in the example below meets these criteria.

Soldering Paste:	OM338 SAC405 / Nr.143714 (Cookson Electronics)
Alloy specification:	95.5% Sn / 3.9% Ag / 0.6% Cu (95.5% Tin / 3.9% Silver / 0.6% Copper) 95.5% Sn / 4.0% Ag / 0.5% Cu (95.5% Tin / 4.0% Silver / 0.5% Copper)
Melting Temperature:	+217 °C
Stencil Thickness:	150 µm for base boards

The final choice of the soldering paste depends on the approved manufacturing procedures.

The stencil geometry for applying soldering paste should meet the recommendations in section [2.14](#).

 The quality of the solder joints should meet the appropriate IPC specification.

### 3.3.2 Reflow soldering

**A convection type soldering oven is strongly recommended** over the infrared type radiation oven. Convection heated ovens allow precise control of the temperature, and all parts will be heated up evenly, regardless of material properties, thickness of components and surface color.

Consider the "IPC-7530A Guidelines for temperature profiling for mass soldering (reflow and wave) processes".

Reflow profiles are to be selected according to the following recommendations.

 Failure to observe these recommendations can result in severe damage to the device!

#### Preheat phase

Initial heating of component leads and balls. Residual humidity will be dried out. Note that this preheat phase will not replace prior baking procedures.

- Temperature rise rate: max 3 °C/s      If the temperature rise is too rapid in the preheat phase, it may cause excessive slumping.
- Time: 60 to 120 s      If the preheat is insufficient, rather large solder balls tend to be generated. Conversely, if performed excessively, fine balls and large balls will be generated in clusters.
- End Temperature: 150 °C to 200 °C      If the temperature is too low, non-melting tends to be caused in areas containing large heat capacity.

#### Heating/ reflow phase

The temperature rises above the liquidus temperature of +217 °C. Avoid a sudden rise in temperature as the slump of the paste could become worse.

- Limit time above +217 °C liquidus temperature: 40 to 60 s
- Peak reflow temperature: +245 °C

## Cooling phase

A controlled cooling avoids negative metallurgical effects (solder becomes more brittle) of the solder and possible mechanical tensions in the products. Controlled cooling helps to achieve bright solder fillets with a good shape and low contact angle.

- Temperature fall rate: max 4 °C/s

To avoid falling off, modules should be placed on the topside of the motherboard during soldering.

The soldering temperature profile chosen at the factory depends on additional external factors, such as the choice of soldering paste, size, thickness and properties of the base board, etc.

Exceeding the maximum soldering temperature and the maximum liquidus time limit in the recommended soldering profile may permanently damage the module.

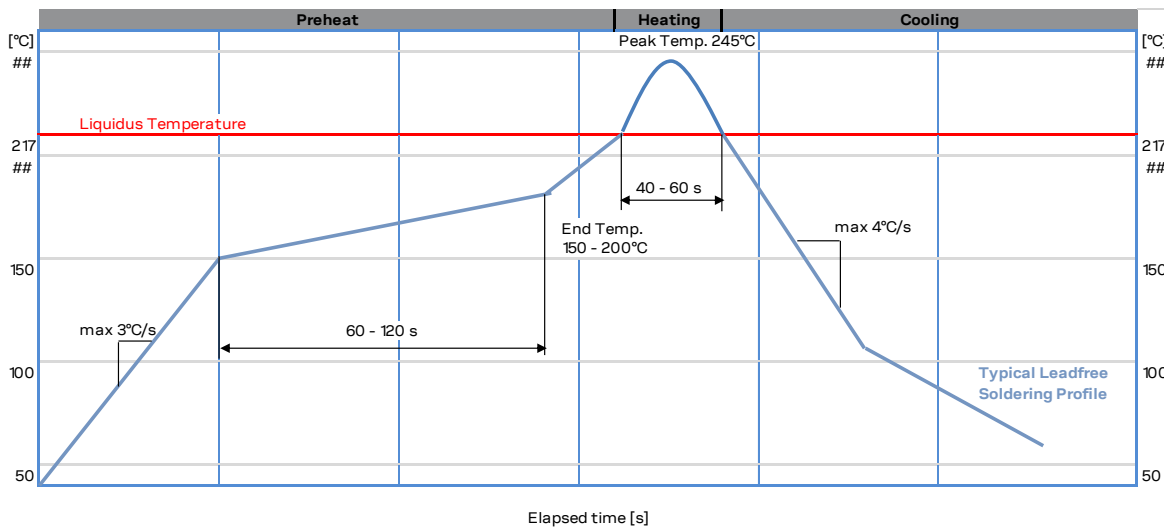

Figure 70: Recommended soldering profile

LENA-R8 series modules must not be soldered with a damp heat process.

## 3.3.3 Optical inspection

After soldering the module, inspect it optically to verify that it is properly aligned and centered.

## 3.3.4 Cleaning

Cleaning the soldered modules is not recommended. Residues underneath the modules cannot be easily removed with a washing process.

- Cleaning with water will lead to capillary effects where water is absorbed in the gap between the baseboard and the module. The combination of residues of soldering flux and encapsulated water leads to short circuits or resistor-like interconnections between neighboring pads. Water will also damage the sticker and the ink-jet printed text.
- Cleaning with alcohol or other organic solvents can result in soldering flux residues flooding into the two housings, areas that are not accessible for post-wash inspections. The solvent will also damage the sticker and the ink-jet printed text.
- Ultrasonic cleaning will permanently damage the module, in particular the quartz oscillators.

For best results, use a "no clean" soldering paste and eliminate the cleaning step after the soldering.

### 3.3.5 Repeated reflow soldering

Repeated reflow soldering processes and soldering the module upside-down are not recommended.



Boards with components on both sides may require two reflow cycles. In this case, the module should always be placed on the side of the board that is submitted into the last reflow cycle. The reason for this (besides others) is the risk of the module falling off due to the significantly higher weight in relation to other components.

-  u-blox gives no warranty against damages to the LENA-R8 series modules caused by performing more than a total of two reflow soldering processes (one reflow soldering process to mount the LENA-R8 series module, plus one reflow soldering process to mount other parts).

### 3.3.6 Wave soldering

LENA-R8 series LGA modules must not be soldered with a wave soldering process.

Boards with combined through-hole technology (THT) components and surface-mount technology (SMT) devices require wave soldering to solder the THT components. No more than one wave soldering process is allowed for a board with a LENA-R8 series module already populated on it.

-  Performing a wave soldering process on the module can result in severe damage to the device!
-  u-blox gives no warranty against damages to the LENA-R8 series modules caused by performing more than a total of two reflow soldering processes (one reflow soldering process to mount the LENA-R8 series module, plus one plus one wave soldering process to mount other THT parts on the application board).

### 3.3.7 Hand soldering

Hand soldering is not recommended.

### 3.3.8 Rework

Rework is not recommended.

-  Never attempt a rework on the module itself, e.g. replacing individual components. Such actions immediately terminate the warranty.

### 3.3.9 Conformal coating

Certain applications employ a conformal coating of the PCB using HumiSeal® or other related coating products. These materials affect the RF properties of the LENA-R8 series modules and it is important to prevent them from flowing into the module. The RF shields do not provide 100% protection for the module from coating liquids with low viscosity, and therefore care is required in applying the coating.

-  Conformal coating of the module will void the warranty.

### 3.3.10 Casting

If casting is required, use viscose or another type of silicon pottant. The OEM is strongly advised to qualify such processes in combination with the LENA-R8 series modules before implementing this in production.

-  Casting will void the warranty.

### 3.3.11 Grounding metal covers

Attempts to improve grounding by soldering ground cables, wick or other forms of metal strips directly onto the EMI covers is done at the customer's own risk. The numerous ground pins should be sufficient to provide optimum immunity to interferences and noise.

-  u-blox gives no warranty for damages to the LENA-R8 series modules caused by soldering metal cables or any other forms of metal strips directly onto the EMI covers.

### 3.3.12 Use of ultrasonic processes

LENA-R8 series modules contain components which are sensitive to ultrasonic waves. Use of any ultrasonic processes (cleaning, welding etc.) may cause damage to the module.

-  u-blox gives no warranty against damages to the LENA-R8 series modules caused by any ultrasonic processes.

## 4 Approvals

 For the complete list and specific details of the certification schemes approvals, see the LENA-R8 series data sheet [1], or please contact the u-blox office or sales representative nearest you.

### 4.1 Product certification approval overview

Product certification approval is the process of certifying that a product has passed all tests and criteria required by specifications, typically called “certification schemes” that can be divided into three distinct categories:

- Regulatory certification
  - Country specific approval required by local government in most regions and countries, as:
    - CE (European Conformity) marking for European Union
    - FCC (Federal Communications Commission) approval for United States
- Industry certification
  - Telecom industry specific approval verifying interoperability between devices and networks:
    - GCF (Global Certification Forum)
    - PTCRB (PCS Type Certification Review Board)
- Operator certification
  - Operator specific approval required by some mobile network operators, such as:
    - AT&T network operator in the United States
    - Verizon Wireless network operator in the United States
    - T-Mobile network operator in the United States

The manufacturer of the end-device that integrates a LENA-R8 series module must take care of all certification approvals required by the specific integrating device to be deployed in the market.

The required certification scheme approvals and relative testing specifications applicable to the end-device that integrates a LENA-R8 series module differ depending on the country or the region where the integrating device is intended to be deployed, on the relative vertical market of the device, on type, features and functionalities of the whole application device, and on the network operators where the device is intended to operate.

 Check the appropriate applicability of the module’s approvals while starting the certification process of the device integrating the module: the re-use of the u-blox cellular module’s approval can significantly reduce the cost and time to market of the application device certification.

 The certification of the application device that integrates a LENA-R8 series module and the compliance of the application device with all the applicable certification schemes, directives and standards are the sole responsibility of the application device manufacturer.

LENA-R8 series modules are certified according to capabilities and options stated in the Protocol Implementation Conformance Statement document (PICS) of the module. The PICS, according to the 3GPP TS 51.010-2 [13], 3GPP TS 36.521-2 [15] and 3GPP TS 36.523-2 [16], is a statement of the implemented and supported capabilities and options of a device.

 The PICS document of the application device integrating a LENA-R8 module must be updated from the module PICS statement if any feature stated as supported by the module in its PICS document is not implemented or disabled in the application device. For more details regarding the AT commands settings that affect the PICS, see the u-blox AT commands manual [2].

 Check the specific settings required for mobile network operators approvals as they may differ from the AT commands settings defined in the module as integrated in the application device.

## 4.2 US Federal Communications Commission notice

FCC ID of LENA-R8 series modules: XPYUBX22EL01

### 4.2.1 Safety warnings review the structure

- Equipment for building-in. Requirements for fire enclosure must be evaluated in the end product
- The clearance and creepage current distances required by the end product must be withheld when the module is installed
- The cooling of the end product shall not negatively be influenced by the installation of the module
- Excessive sound pressure from earphones and headphones can cause hearing loss
- No natural rubbers, no hygroscopic materials nor materials containing asbestos are employed

### 4.2.2 Declaration of conformity

This device complies with Part 15 of the FCC rules and with the ISED Canada license-exempt RSS standard(s). Operation is subject to the following two conditions:

- this device may not cause harmful interference
- this device must accept any interference received, including interference that may cause undesired operation

 Radiofrequency radiation exposure Information: this equipment complies with FCC radiation exposure limits prescribed for an uncontrolled environment for fixed and mobile use conditions. This equipment should be installed and operated with a minimum distance of 20 cm between the radiator and the body of the user or nearby persons. This transmitter must not be co-located or operating in conjunction with any other antenna or transmitter except in accordance with FCC procedures and as authorized in the module certification filing.

 The gain of the system antenna(s) used for the modules (i.e. the combined transmission line, connector, cable losses and radiating element gain) must not exceed the value specified in the FCC Grant for mobile and/or fixed operating configurations

- 9.6 dBi in the LTE FDD-12 band uplink (699..716 MHz)
- 7.6 dBi in the GSM 850 band uplink (814..849 MHz)
- 10.4 dBi in the LTE FDD-5 band uplink (814..849 MHz)
- 6.0 dBi in the LTE FDD-4 band uplink (1710..1755 MHz)
- 6.0 dBi in the LTE FDD-66 band uplink (1710..1780 MHz)
- 2.0 dBi in the GSM 1900 band uplink (1850..1910 MHz)
- 9.0 dBi in the LTE FDD-2 band uplink (1850..1910 MHz)
- 9.0 dBi in the LTE FDD-7 band uplink (2500..2570 MHz)
- 9.0 dBi in the LTE TDD-38 band uplink (2570..2620 MHz)
- 9.0 dBi in the LTE TDD-41 band uplink (2496.. 2690 MHz)

### 4.2.3 Modifications

The FCC requires the user to be notified that any changes or modifications made to this device that are not expressly approved by u-blox could void the user's authority to operate the equipment.

 Manufacturers of mobile or fixed devices incorporating LENA-R8 series modules are authorized to use the FCC Grants of the LENA-R8 series modules for their own final products according to the conditions referenced in the certificates.

 The FCC Label shall in the above case be visible from the outside, or the host device shall bear a second label stating: "Contains FCC ID: XPYUBX22EL01" resp.

**⚠ IMPORTANT:** Manufacturers of portable applications incorporating the LENA-R8 series modules are required to have their final product certified and apply for their own FCC Grant related to the specific portable device. This is mandatory to meet the SAR requirements for portable devices.

Changes or modifications not expressly approved by the party responsible for compliance could void the user's authority to operate the equipment.

**⚠ Additional Note:** Part 15 limits of the FCC Rules for a Class B digital device are designed to provide reasonable protection against harmful interference in a residential installation. This equipment generates, uses and can radiate radio frequency energy and, if not installed and used in accordance with the instructions, may cause harmful interference to radio communications. However, there is no guarantee that interference will not occur in a particular installation. If this equipment does cause harmful interference to radio or television reception, which can be determined by turning the equipment off and on, the user is encouraged to try to correct the interference by one or more of the following measures:

- Reorient or relocate the receiving antenna
- Increase the separation between the equipment and receiver
- Connect the equipment into an outlet on a circuit different from that to which the receiver is connected
- Consult the dealer or an experienced radio/TV technician for help

## 4.3 Innovation, Science, Economic Development Canada notice

ISED Certification Number of LENA-R8 series modules: 8595A-UBX22EL01

### 4.3.1 Declaration of Conformity

This device complies with the ISED Canada license-exempt RSS standard(s). Operation is subject to the following two conditions:

- this device may not cause harmful interference
- this device must accept any interference received, including interference that may cause undesired operation

**⚠ Radiofrequency radiation exposure Information:** this equipment complies with radiation exposure limits prescribed for an uncontrolled environment for fixed and mobile use conditions. This equipment should be installed and operated with a minimum distance of 20 cm between the radiator and the body of the user or nearby persons. This transmitter must not be co-located or operating in conjunction with any other antenna or transmitter except as authorized in the certification of the product.

**⚠** The gain of the system antenna(s) used for the modules (i.e. the combined transmission line, connector, cable losses and radiating element gain) must not exceed the values specified in the ISED Canada Certificate Grant for mobile and/or fixed operating configurations

- 6.6 dBi in the LTE FDD-12 band uplink (699..716 MHz)
- 6.6 dBi in the GSM 850 band uplink (814..849 MHz)
- 7.1 dBi in the LTE FDD-5 band uplink (814..849 MHz)
- 6.0 dBi in the LTE FDD-4 band uplink (1710..1755 MHz)
- 6.0 dBi in the LTE FDD-66 band uplink (1710..1780 MHz)
- 2.0 dBi in the GSM 1900 band uplink (1850..1910 MHz)
- 9.0 dBi in the LTE FDD-2 band uplink (1850..1910 MHz)
- 9.0 dBi in the LTE FDD-7 band uplink (2500..2570 MHz)
- 9.0 dBi in the LTE TDD-38 band uplink (2570..2620 MHz)
- 9.0 dBi in the LTE TDD-41 band uplink (2496.. 2690 MHz)

### 4.3.2 Modifications

ISED Canada requires the user to be notified that any changes or modifications made to this device that are not expressly approved by u-blox could void the user's authority to operate the equipment.

 Manufacturers of mobile or fixed devices incorporating LENA-R8 series modules are authorized to use the ISED Canada Certificates of the LENA-R8 series modules for their own final products according to the conditions referenced in the certificates.

 The ISED Canada Label shall in the above case be visible from the outside, or the host device shall bear a second label stating: "Contains IC: 8595A-UBX22EL01" resp.

 **Innovation, Science and Economic Development Canada (ISED) Notices**

This Class B digital apparatus complies with Canadian CAN ICES-3(B) / NMB-3(B) and RSS-210. Operation is subject to the following two conditions:

- this device may not cause interference
- this device must accept any interference, including interference that may cause undesired operation of the device

 **Radio Frequency (RF) Exposure Information**

The radiated output power of the module is below the Innovation, Science and Economic Development Canada (ISED) radio frequency exposure limits. The module should be used in such a manner such that the potential for human contact during normal operation is minimized.

This device has been evaluated and shown compliant with the ISED RF Exposure limits under mobile exposure conditions (antennas are greater than 20 cm from a person's body).

This device has been certified for use in Canada. Status of the listing in the Innovation, Science and Economic Development's REL (Radio Equipment List) can be found at the following web address: <http://www.ic.gc.ca/app/sitt/relet/srch/nwRdSrch.do?lang=eng>

Additional Canadian information on RF exposure also can be found at the following web address: <http://www.ic.gc.ca/eic/site/smt-gst.nsf/eng/sf08792.html>

 **IMPORTANT:** Manufacturers of portable applications incorporating the modules are required to have their final product certified and apply for their own Innovation, Science and Economic Development Certificate related to the specific portable device. This is mandatory to meet the SAR requirements for portable devices.

Changes or modifications not expressly approved by the party responsible for compliance could void the user's authority to operate the equipment.

**⚠ Avis d'Innovation, Sciences et Développement économique Canada (ISDE)**

Cet appareil numérique de classe B est conforme aux normes canadiennes CAN ICES-3(B) / NMB-3(B) et CNR-210. Son fonctionnement est soumis aux deux conditions suivantes :

- cet appareil ne doit pas causer d'interférence
- cet appareil doit accepter toute interférence, notamment les interférences qui peuvent affecter son fonctionnement

**⚠ Informations concernant l'exposition aux fréquences radio (RF)**

La puissance de sortie émise par l'appareil de sans fil module est inférieure à la limite d'exposition aux fréquences radio d'Innovation, Sciences et Développement économique Canada (ISDE). Utilisez l'appareil de sans fil module de façon à minimiser les contacts humains lors du fonctionnement normal.

Ce périphérique a été évalué et démontré conforme aux limites d'exposition aux fréquences radio (RF) d'IC lorsqu'il est installé dans des produits hôtes particuliers qui fonctionnent dans des conditions d'exposition à des appareils mobiles (les antennes se situent à plus de 20 centimètres du corps d'une personne).

Ce périphérique est homologué pour l'utilisation au Canada. Pour consulter l'entrée correspondant à l'appareil dans la liste d'équipement radio (REL - Radio Equipment List) d'Industrie Canada rendez-vous sur: <http://www.ic.gc.ca/app/sitt/reitel/srch/nwRdSrch.do?lang=fra>

Pour des informations supplémentaires concernant l'exposition aux RF au Canada rendez-vous sur: <http://www.ic.gc.ca/eic/site/smt-gst.nsf/fra/sf08792.html>

**⚠ IMPORTANT:** les fabricants d'applications portables contenant les modules doivent faire certifier leur produit final et déposer directement leur candidature pour une certification FCC ainsi que pour un certificat ISDE Canada délivré par l'organisme chargé de ce type d'appareil portable. Ceci est obligatoire afin d'être en accord avec les exigences SAR pour les appareils portables.

Tout changement ou modification non expressément approuvé par la partie responsable de la certification peut annuler le droit d'utiliser l'équipement.

## 4.4 European Conformance CE mark

LENA-R8 series modules have been evaluated against the essential requirements of the Radio Equipment Directive 2014/53/EU. To satisfy the essential requirements of the 2014/53/EU RED, the modules are compliant with the following standards:

- Radio Spectrum Efficiency (Article 3.2):
  - EN 301 511
  - EN 301 908-1
  - EN 301 908-13
  - EN 303 413
- Electromagnetic Compatibility (Article 3.1b):
  - EN 301 489-1
  - EN 301 489-19
  - EN 301 489-52
- Health and Safety (Article 3.1a)
  - EN 62368-1
  - EN 62311

 Radiofrequency radiation exposure information: this equipment complies with radiation exposure limits prescribed for an uncontrolled environment for fixed and mobile use conditions. This equipment should be installed and operated with a minimum distance of 20 cm between the radiator and the body of the user or nearby persons. This transmitter must not be co-located or operating in conjunction with any other antenna or transmitter except as authorized in the certification of the product.

 The gain of the system antenna(s) used for the LENA-R8 series modules (i.e. the combined transmission line, connector, cable losses and radiating element gain) must not exceed the values reported in the Declaration of Conformity for mobile and fixed or mobile operating configurations

- 8.4 dBi in LTE FDD-28 band uplink (703..748 MHz)
- 9.2 dBi in LTE FDD-20 band uplink (832..862 MHz)
- 8.9 dBi in GSM 900 band uplink (880..915 MHz)
- 9.4 dBi in LTE FDD-8 band uplink (880..915 MHz)
- 14.8 dBi in GSM 1800 band uplink (1710..1785 MHz)
- 12.3 dBi in LTE FDD-3 band uplink (1710..1785 MHz)
- 12.8 dBi in LTE FDD-1 band uplink (1850..1910 MHz)
- 12.9 dBi in LTE TDD-40 band uplink (2300..2400 MHz)
- 12.9 dBi in LTE FDD-7 band uplink (2500..2570 MHz)
- 12.9 dBi in LTE TDD-38 band uplink (2570..2620 MHz)

The conformity assessment procedure for the modules, referred to in Article 17 and detailed in Annex II of Directive 2014/53/EU, has been followed.

Thus, the following marking is included in the product:





## 4.5 UK Conformity Assessed (UKCA)

 The United Kingdom is made up of the Great Britain (including England, Wales and Scotland) and the Northern Ireland. The Northern Ireland continues to accept the CE marking. Following notice is applicable to the Great Britain only.

The LENA-R8 series modules have been evaluated against the essential requirements of the Radio Equipment Regulations 2017 (SI 2017 No. 1206, as amended by SI 2019 No. 696). To satisfy the essential requirements of the UK Legislation, the modules are compliant with the following standards:

- Radio Spectrum Efficiency (Article 6.2):
  - EN 301 511
  - EN 301 908-1
  - EN 301 908-13
  - EN 303 413
- Electromagnetic Compatibility (Article 6.1b):
  - EN 301 489-1
  - EN 301 489-19
  - EN 301 489-52
- Health and Safety (Article 6.1a)
  - EN 62368-1
  - EN 62311

-  Radiofrequency radiation exposure information: this equipment complies with radiation exposure limits prescribed for an uncontrolled environment for fixed and mobile use conditions. This equipment should be installed and operated with a minimum distance of 20 cm between the radiator and the body of the user or nearby persons. This transmitter must not be co-located or operating in conjunction with any other antenna or transmitter except as authorized in the certification of the product.
-  The gain of the system antenna(s) used for the LENA-R8 series modules (i.e. the combined transmission line, connector, cable losses and radiating element gain) must not exceed the values reported in the Declaration of Conformity for mobile and fixed or mobile operating configurations
- 8.4 dBi in LTE FDD-28 band uplink (703..748 MHz)
  - 9.2 dBi in LTE FDD-20 band uplink (832..862 MHz)
  - 8.9 dBi in GSM 900 band uplink (880..915 MHz)
  - 9.4 dBi in LTE FDD-8 band uplink (880..915 MHz)
  - 14.8 dBi in GSM 1800 band uplink (1710..1785 MHz)
  - 12.3 dBi in LTE FDD-3 band uplink (1710..1785 MHz)
  - 12.8 dBi in LTE FDD-1 band uplink (1850..1910 MHz)
  - 12.9 dBi in LTE TDD-40 band uplink (2300..2400 MHz)
  - 12.9 dBi in LTE FDD-7 band uplink (2500..2570 MHz)
  - 12.9 dBi in LTE TDD-38 band uplink (2570..2620 MHz)

The conformity assessment procedure for the modules, referred to Part 3 of the Radio Equipment Regulations 2017, has been followed.



Guidance about using the UKCA marking: <https://www.gov.uk/guidance/using-the-ukca-marking>



## 4.6 Australian conformance

The LENA-R8 series modules are compliant with the applicable standards made by the Australian Communications and Media Authority (ACMA).

The devices are “solder-down” modules (soldered to the PCB of the final product) and they do not have a stand-alone function. The devices are not within the scope of any RCM Labelling notice accordingly. The devices are excluded under Schedule 2 of the ACMA Telecommunications Labelling Notice 2015 and under Schedule 2 of the EMC Labelling Notice.

-  Responsibility for compliance with any ACMA RCM Labelling notice rests solely with the integrator of the u-blox modules.
-  The antenna used for the u-blox modules must not be closer than 20 cm to the nearest person, otherwise Specific Absorption Rate (SAR) evaluation is required to prevent possible RF exposure exceeding the limits defined by the Australian Radiation Protection and Nuclear Safety Agency - Radiation Protection Series 3 (ARPANSA-RSP3).

## 5 Product testing

### 5.1 Validation testing and qualification

LENA-R8 series modules are validated and tested by u-blox in the operating conditions and in certain integration scenarios, but not all the specific characteristics of the host application end-product integrating the module can be validated and tested by u-blox.

LENA-R8 series modules are also qualified by u-blox according to u-blox policy, which is based on the AEC-Q104 standard, but the specific characteristics of the host application end-product integrating the module cannot be qualified by u-blox.

Therefore, and to be on the safe side, u-blox recommends that integrators of LENA-R8 series modules validate, verify, qualify, and test the host product integrating the module. Take into consideration all the possible aspects, to make sure that the specific characteristics of the host application do not lead to reduced / non-performance of the LENA-R8 series modules.

Host product manufacturers are responsible to follow all the integration guidelines included in this manual, and to perform a set of verification tests to ensure the host end-product complies with applicable functional and/or conformity requirements.

Care must be taken in the validation of the antenna RF circuits implemented in the host product for the module, as they may affect compliance with applicable RF conformity requirements.

The 50  $\Omega$  characteristic impedance of the antenna trace design on a host printed circuit board can be verified using a Vector Network Analyzer, as done on the u-blox host PCB, with a calibrated RF coaxial cable soldered at the pad corresponding to RF input/output of the module and with the transmission line terminated to a 50  $\Omega$  load at the 50  $\Omega$  SMA female connector.

Compliance of the design with RF regulatory rules defined by the FCC, ISED, RED, etc. can be verified using a radio communication tester (callbox), as for example the Rohde & Schwarz CMW500, or any equivalent equipment for multi-radio technology signaling conformance tests. Consider involving an accredited testing laboratory to verify compliance with RF regulatory rules.

Care must be taken in the validation of the VCC power supply circuit implemented in the host product for the module, as the specific characteristics of the power supply circuit may affect compliance with applicable functional and/or conformity requirements.

Adequateness of the power supply circuit capability can be checked by forcing the module to transmit at the maximum power level in the supported radio access technologies using a radio communication tester (callbox) as the Rohde & Schwarz CMW500 or any equivalent equipment.

Care must be taken in the validation of the SIM interface circuit implemented in the host product for the module. It is important to check the rise times of the signals, as the external circuit design may affect compliance with applicable functional and/or specification requirements.

Care must be taken in the validation of any interface circuit connected to the module as implemented in the host product. Check the power-on, power-off and reset circuits, also with any related switch-on, switch-off, and reset procedures. Check the communication interfaces (as UARTs, USB, I2C), and any other circuit designed in the host product in combination with any other interface of the module (as audio, GPIOs, etc.), as the external design implemented in the host product may affect compliance with applicable functional requirements.

 The validation, verification, qualification, and testing of the application host device integrating a LENA-R8 series module and the compliance of the application host device with all the applicable functional and/or conformity specifications and requirements are under the sole responsibility of the application host device manufacturer.

## 5.2 Production testing

### 5.2.1 u-blox in-line production test

u-blox focuses on high quality for its products. All units produced are automatically tested in all the interfaces along the production line. A stringent quality control process has been implemented in the production line. Defective units are analyzed in detail to improve production quality.

This is achieved with automatic test equipment (ATE) implemented in the production line, logging all production and measurement data. A detailed test report for each unit can be generated from the system. [Figure 64](#) illustrates the typical automatic test equipment (ATE) in a production line.

The following typical tests are among the production tests.

- Digital self-test (firmware download, Flash firmware verification, IMEI programming)
- Measurement of voltages and currents
- Adjustment of ADC measurement interfaces
- Functional tests (serial interface communication, SIM card communication)
- Digital tests (GPIOs and other interfaces)
- Measurement and calibration of RF characteristics in supported bands (such as frequency tuning, calibration of transmitter and receiver power levels, etc.)
- Verification of RF characteristics after calibration (such as modulation, power levels, spectrum, etc. are checked to ensure they are all within tolerances when calibration parameters are applied)

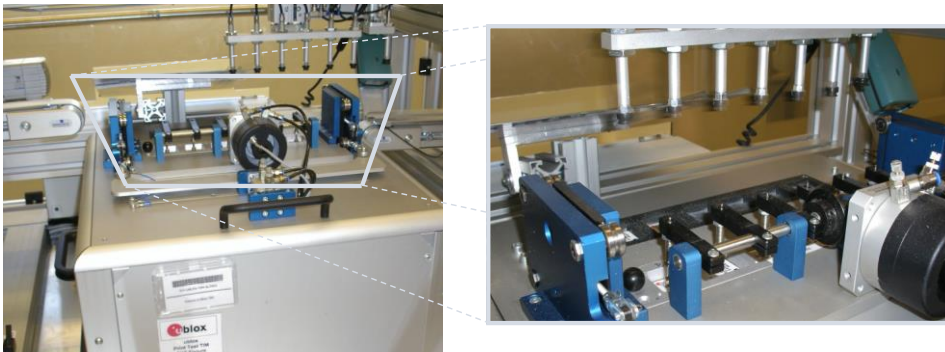

Figure 71: Automatic test equipment for module tests

### 5.2.2 Production test parameters for OEM manufacturers

Because of the testing performed by u-blox (with 100% coverage), an OEM manufacturer does not need to repeat firmware tests or measurements of the module RF performance or tests over analog and digital interfaces in their production test.

An OEM manufacturer should focus on:

- Module assembly on the device; it should be verified that:
  - Soldering and handling processes did not damage the module components
  - All module pins are well soldered on the device board
  - There are no short circuits between pins
- Component assembly on the device; it should be verified that:
  - Communications with host controller can be established
  - The interfaces between the module and device are working
  - The RF interfaces of the device, including antennas, are working

Dedicated tests can be implemented to check the device. For example, the consumption measured in a specified status can detect a short circuit if compared with a “Golden Device” result.

In addition, module AT commands can be used to perform functional tests on digital interfaces, as for example (for more details about AT commands, see the u-blox AT commands manual [2]):

- communication with host controller can be checked by AT command,
- communication with SIM card/chip can be checked by dedicated +CPIN read command,
- communication with external I2C devices can be checked by dedicated AT commands,
- GPIOs functionality can be checked by dedicated +UGPIOC AT command, etc.

 Please contact the u-blox office or sales representative nearest you for further guidelines about OEM production testing guidelines.

### 5.2.2.1 “Go/No go” production tests for integrated devices

A “Go/No go” test is typically performed to compare the signal quality with a “Golden Device” in a location with excellent network coverage and known signal quality. This test should be performed after data connection has been established. AT+CSQ is the typical AT command used to check signal quality in term of RSSI (for more details, see the u-blox AT commands manual [2]).

 These kinds of test may be useful as a “go / no go” test, not for RF performance measurements.

This test is suitable to check the functionality of communication with the host controller, the SIM, and the power supply. It is also a means to verify if the parts at antenna interface are well soldered.

### 5.2.2.2 Functional production tests providing GNSS RF operation

The best way to test the GNSS RF functionality is with the use of a GNSS simulator, as it assures reliable and constant signals at every measurement. Spirent, Rohde & Schwarz, and Orolia amongst other manufacturers offer such devices.

Guidelines for GNSS RF functionality tests:

- Connect a GNSS generator to the OEM product.
- Choose the power level in a way that the “Golden Device” would report a C/No ratio of 38-40 dBHz.
- Power up the DUT (Device Under Test) and allow enough time for the acquisition.
- Read the C/No value from the NMEA GSV or any UBX message reporting it (e.g. with u-center).
- Compare the results to a “Golden Device”.

### 5.2.2.3 Persistent configurations

The modules are delivered by u-blox with predefined factory-programmed settings that can be changed using AT commands according to application-specific requirements. Some settings are persistent, stored in the module's non-volatile memory, and re-used at any subsequent reboot. Among these, for example, there are the UART baud rate, frame format, flow control, etc., the greeting text, the APN for Internet connectivity, etc. (For more details, see the AT command manual[2]).

After verifying the proper assembly of the module and related parts on the application device, execute a persistent configuration setting phase in OEM production line, configuring the module according to the intended use in the specific application, as the persistent configurations are intended to be set only once and then re-used at any subsequent reboot.

During the persistent configuration setting phase, it is recommended to configure the baud rate, frame format, flow control and any other settings for the UART interface according to the use case. It is also recommended to configure the greeting text, and the APN for internet connectivity, etc.

# Appendix

## A Migration from LARA to LENA-R8 modules

 Detailed and updated guidelines to migrate from u-blox LARA-R2 / LARA-R6 / LARA-L6 modules to u-blox LENA-R8 modules are available in the u-blox LARA / LENA modules migration guidelines application note [\[20\]](#).

## B Glossary

Abbreviation	Definition
2G	2nd Generation Cellular Technology (GSM, GPRS, EGPRS)
3G	3rd Generation Cellular Technology (UMTS, HSDPA, HSUPA)
3GPP	3rd Generation Partnership Project
8-PSK	8 Phase-Shift Keying modulation
16QAM	16-state Quadrature Amplitude Modulation
ACMA	Australian Communications and Media Authority
ADC	Analog to Digital Converter
ANATEL	Agência Nacional de Telecomunicações - National Telecommunications Agency (Brazil)
APAC	Asia-Pacific
ASIC	Application-Specific Integrated Circuit
AT	AT Command Interpreter Software Subsystem
ATE	Automatic Test Equipment
AUX	Auxiliary
BAW	Bulk Acoustic Wave
BBR	Battery-Backed RAM
BJT	Bipolar Junction Transistor
Cat	Category
CDC	Communication Device Class
CDMA	Code-Division Multiple Access
CE	Conformité Européenne (European Conformity)
GENELEC	Comité Européen de Normalisation Électrotechnique (European Committee for Electrotechnical Normative)
CS	Coding Scheme
CSFB	Circuit Switched Fall-Back
CTS	Clear To Send
DC	Direct Current
DCD	Data Carrier Detect
DCE	Data Communication Equipment
DDC	Display Data Channel interface
DL	Down-Link (Reception)
DRX	Discontinuous Reception
DSP	Digital Signal Processing
DSR	Data Set Ready
DTE	Data Terminal Equipment
DTLS	Datagram Transport Layer Security

Abbreviation	Definition
DTR	Data Terminal Ready
ECC	Envelope Correlation Coefficient
EDGE	Enhanced Data rates for GSM Evolution (EGPRS)
eDRX	Extended Discontinuous Reception
EGPRS	Enhanced General Packet Radio Service (EDGE)
EMC	Electro-magnetic Compatibility
EMEA	Europe, the Middle East and Africa
EMI	Electro-magnetic Interference
EPA	Electrostatic Protective Area
ESD	Electro-static Discharge
ESR	Equivalent Series Resistance
ETSI	European Telecommunications Standards Institute
FCC	Federal Communications Commission (United States)
FDD	Frequency Division Duplex
FEM	Front End Module
FOAT	(Update via) Firmware Over AT commands
FOTA	Firmware Over The Air
FTP	File Transfer Protocol
FW	Firmware
GCF	Global Certification Forum
GERA	GSM EGPRS Radio Access
GITEKI	Gijutsu kijun tekigō shōmei - technical standard conformity certification (Japan)
GLONASS	Russian GLObal Navigation Satellite System
GMSK	Gaussian Minimum-Shift Keying modulation
GND	Ground
GNSS	Global Navigation Satellite System
GPIO	General Purpose Input Output
GPRS	General Packet Radio Services
GPS	Global Positioning System
GSM	Global System for Mobile Communication
HBM	Human Body Model
HSIC	High Speed Inter Chip
HSDPA	High Speed Downlink Packet Access
HSUPA	High Speed Uplink Packet Access
HTTP	HyperText Transfer Protocol
HW	Hardware
I/Q	In-phase and Quadrature
I2C	Inter-Integrated Circuit interface
I2S	Inter IC Sound interface
IC	Integrated Circuit
ICES	Interference-Causing Equipment Standard
IEC	International Electrotechnical Commission
IEEE	Institute of Electrical and Electronics Engineers
IMEI	International Mobile Equipment Identity
IP	Internet Protocol
ISED	Innovation, Science, Economic Development (Canada)

Abbreviation	Definition
ISO	International Organization for Standardization
ITU	International Telecommunications Union
KC	Korea Certification
LCC	Leadless Chip Carrier
LDO	Low-Dropout
LED	Light Emitting Diode
LGA	Land Grid Array
LNA	Low Noise Amplifier
LPDDR	Low Power Double Data Rate synchronous dynamic RAM memory
LPWA	Low Power Wide Area
LSB	Least Significant Bit
LTE	Long Term Evolution
LwM2M	Open Mobile Alliance Lightweight Machine-to-Machine protocol
M2M	Machine to machine
MCS	Modulation Coding Scheme
MIMO	Multiple In Multiple Out
MNO	Mobile Network Operator
MOSFET	Metal-Oxide-Semiconductor Field-Effect Transistor
MPE	Maximum Permissible Exposure
MQTT	Message Queuing Telemetry Transport
MQTT-SN	Message Queuing Telemetry Transport for Sensor Networks
MSB	Most Significant Bit
MSD	Moisture Sensitive Device
MUX	Multiplexer
N/A	Not Applicable
NCC	National Communications Commission (Taiwan)
NCM	Network Control Model
NMB	Norme sur le Matériel Brouilleur (Interference-Causing Equipment Standard)
NSMD	Non Solder Mask Defined
NTC	Negative Temperature Coefficient
OEM	Original Equipment Manufacturer device: an application device integrating a u-blox cellular module
OTA	Over The Air
PA	Power Amplifier
PCB	Printed Circuit Board
PCM	Pulse Code Modulation
PCN	Product Change Notification
PFM	Pulse Frequency Modulation
PIO	Peripheral Input/Output
PMU	Power Management Unit
PTCRB	PCS Type Certification Review Board
PWM	Pulse Width Modulation
QPSK	Quadrature Phase Shift Keying
RCM	Regulatory Compliance Mark
RED	Radio Equipment Directive
RF	Radio Frequency
RSE	Radiated Spurious Emission

Abbreviation	Definition
RSS	Radio Standards Specification
RSVD	Reserved
RTC	Real Time Clock
Rx	Receive
SAR	Specific Absorption Rate
SAW	Surface Acoustic Wave
SDIO	Secure Digital Input Output
SIM	Subscriber Identification Module
SMD	Solder Mask Defined
SMS	Short Message Service
SMT	Surface-Mount Technology
SP4T	Single-Pole Four-Throw
SPG	Standard Precision GNSS
SRF	Self-Resonant Frequency
SSL	Secure Sockets Layer
STS	Smart Temperature Supervisor
TBD	To Be Defined
TCP	Transmission Control Protocol
TCXO	Temperature-Controlled Crystal Oscillator
TDD	Time Division Duplex
TDMA	Time Division Multiple Access
THT	Through-Hole Technology
TI	Texas Instruments
TIS	Total Isotropic Sensitivity
TLS	Transport Layer Security
TP	Test-Point
TRP	Total Radiated Power
TTF	Time-To-First-Fix
Tx	Transmit
UART	Universal Asynchronous Receiver-Transmitter
UDP	User Datagram Protocol
uFOTA	u-blox Firmware update Over The Air
UICC	Universal Integrated Circuit Card
UKCA	United Kingdom Conformity Assessed
UL	Up-Link (Transmission)
UMTS	Universal Mobile Telecommunications System
URC	Unsolicited Result Code
USB	Universal Serial Bus
UTRA	UMTS Terrestrial Radio Access
VCC	Voltage Common Collector
VCO	Voltage Controlled Oscillator
VoLTE	Voice over LTE
VSWR	Voltage Standing Wave Ratio
Wi-Fi	Wireless Local Area Network (IEEE 802.11 short range radio technology)

## Related documentation

- [1] u-blox LENA-R8 series data sheet, [UBX-22003110](#)
- [2] u-blox LENA-R8 series AT commands manual, [UBX-22016905](#)
- [3] u-blox UBX-M10050-KB standard precision GNSS chip data sheet, [UBX-20043795](#)
- [4] u-blox UBX-M10050-KB standard precision GNSS chip integration manual, [UBX-20049918](#)
- [5] u-blox M10 SPG 5.10 interface description, [UBX-21035062](#)
- [6] u-blox GNSS antennas application note, [UBX-15030289](#)
- [7] ITU-T recommendation V.24 - List of definitions for interchange circuits between the Data Terminal Equipment (DTE) and the Data Circuit-terminating Equipment (DCE), <https://www.itu.int/rec/T-REC-V.24-200002-l/en>
- [8] 3GPP TS 27.007 – AT command set for User Equipment (UE)
- [9] 3GPP TS 27.005 – Use of Data Terminal Equipment - Data Circuit-terminating Equipment (DTE-DCE) interface for Short Message Service (SMS) and Cell Broadcast Service (CBS)
- [10] 3GPP TS 27.010 – Terminal Equipment to User Equipment (TE-UE) multiplexer protocol
- [11] Universal Serial Bus Revision 2.0 specification, <https://www.usb.org/>
- [12] I2C-bus specification and user manual - UM10204, <https://www.nxp.com/>
- [13] 3GPP TS 51.010-2 – Technical Specification Group GSM/EDGE Radio Access Network; Mobile Station (MS) conformance specification; Part 2: Protocol Implementation Conformance Statement (PICS)
- [14] 3GPP TS 36.521-1 - Evolved Universal Terrestrial Radio Access; User Equipment conformance specification; Radio transmission and reception; Part 1: Conformance Testing
- [15] 3GPP TS 36.521-2 - Evolved Universal Terrestrial Radio Access (E-UTRA); User Equipment conformance specification; Radio transmission and reception; Part 2: Implementation Conformance Statement (ICS)
- [16] 3GPP TS 36.523-2 - Evolved Universal Terrestrial Radio Access (E-UTRA) and Evolved Packet Core (EPC); User Equipment conformance specification; Part 2: Implementation Conformance Statement (ICS)
- [17] GSM Association TS.09 - Battery Life Measurement and Current Consumption Technique <https://www.gsma.com/newsroom/wp-content/uploads/TS.09-v12.pdf>
- [18] u-blox package information user guide, [UBX-14001652](#)
- [19] u-blox B36 vehicle tracking blueprint product summary, [UBX-20012630](#)
- [20] u-blox LARA / LENA migration guidelines application note, [UBX-21010015](#)

 For regular updates to u-blox documentation and to receive product change notifications, register on our homepage ([www.u-blox.com](http://www.u-blox.com)).

## Revision history

Revision	Date	Name	Comments
R01	06-Jul-2022	sses	Initial release
R02	04-Oct-2022	sses	Updated LENA-R8001-00C product status. Revised UART interfaces capabilities. Revised AUX UART application circuit. Added Ethernet-over-USB capabilities. Revised I2C and I2S application circuits. Minor other clarifications and corrections.
R03	17-Apr-2023	sses	Updated LENA-R8001M10-00C product status. Revised futures available or planned for initial and future product FW versions (auxiliary UART, I2C, I2S, clock output, PSM, eDRX, SIM detection, Antenna dynamic tuning). Revised VoLTE and CSFB support. Added regulatory approval for Australia. Other minor clarifications and corrections.

# Contact

## u-blox AG

Address: Zürcherstrasse 68  
8800 Thalwil  
Switzerland

For further support and contact information, visit us at [www.u-blox.com/support](http://www.u-blox.com/support).