

MARKING DIP SWITCHES

1. Production date code (No. 1)

Production date code is exhibited on each product as shown in below.

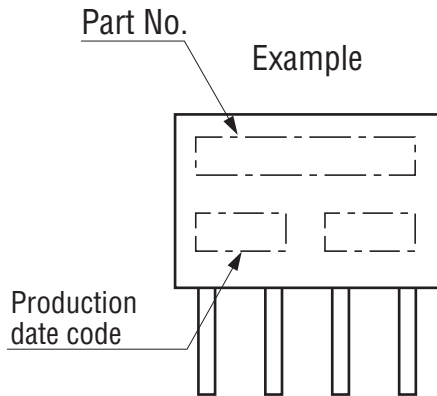

Note

- Date code marking position is per outline drawing of each model.
- Marking of Part No. is made for the following models.

S-1000A/2000A	RD
SA-5000	SS-10 (Rotary switches)
S-8000	RS/RG (Rotary switches)

Production date code

year	code	Month	code
1999	9	1	A
2000	0	2	B
2001	1	3	C
2002	2	4	D
2003	3	5	E
2004	4	6	F
2005	5	7	G
2006	6	8	H
2007	7	9	J
2008	8	10	Y
2009	9	11	L
2010	0	12	M
...	...	—	—

Date code, in principle, consists of one digit and one capital letter. Per above table the last digit of year represents, a year while a capital letter a month.

Example) 8J Manufactured in Sep. of 2008.

Models of date code application

DIP switches

CVS
CHS
CHP
CFS
CES
CFP
CYP
RD
S-1000A/2000A
SC-1000/2000
SD-1000/2000
S-4000
SA-5000
SA-7000
S-7000
SH-7000
S-8000

Slide switches

CJS
CAS
CL-SA
CL-SB
CRFS
CMS
CUS
CSS

Rotary switches

CS-4
CS-7
SS-10
RS/RG

Pushbutton (Detect) switches

CL-DA
CL-DB

1. Production date code (No. 2)

Production date code is exhibited on each product as shown in below.

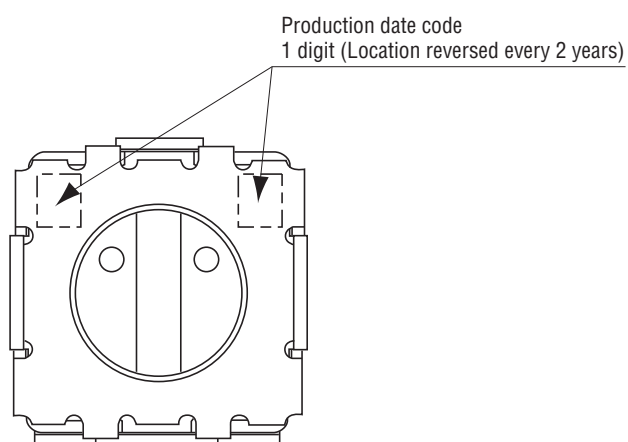

The model that this marking method is applicable : Rotary switch CS-32

Production date code

Stamping position	Year			
	Upper right	Upper left		Upper right
Month	1999 2003 2007	2000 2004 2008	2001 2005 2009	2002 2006 2010
1	A	N	A	N
2	B	P	B	P
3	C	Q	C	Q
4	D	R	D	R
5	E	S	E	S
6	F	T	F	T
7	G	U	G	U
8	H	V	H	V
9	J	W	J	W
10	K	X	K	X
11	L	Y	L	Y
12	M	Z	M	Z

In principle, capitals per the table are used, commencing with January of 2001 as A in order. The same arrangement will be repeated after 48 months or 4 years.

2. Coating and potting

If the switch is coated or potted, the movable parts may lock, making readjustment difficult.

Further, if coating or potting is made, make sure that the hardening temperature does not exceed 70°C .

In actual coating and potting, please make sure before use that the using conditions differ respectively.

Please note that the CVS, CHS, CHP, CFP, CYP, CES & Slide switches CJS, CAS, CL-SA, CL-SB, CRFS, CMS, CUS, CSS are not of sealed construction and therefore cannot be coated or potted.

For details, please refer to page 153.